

GEMÜ 0322

Electrically operated pilot solenoid valve

EN **Operating instructions**



All rights including copyrights or industrial property rights are expressly reserved.

Keep the document for future reference.

© GEMÜ Gebr. Müller Apparatebau GmbH & Co. KG
07.03.2023

Contents

1	General information	4
1.1	Information	4
1.2	Symbols used	4
1.3	Definition of terms	4
1.4	Warning notes	4
2	Safety information	5
3	Product description	5
3.3	Functional description	5
3.3.1	Safety function	5
4	GEMÜ CONEXO	5
5	Correct use	6
6	Order data	7
7	Technical data	9
8	Dimensions	11
9	Manufacturer's information	12
9.1	Delivery	12
9.2	Transport	12
9.3	Storage	12
10	Installation	12
11	Electrical connection	14
11.1	Plug design A	15
11.2	M12 plug (code 02, 03)	15
11.3	Manual override (option)	15
12	Commissioning	16
13	Troubleshooting	16
14	Inspection and maintenance	16
15	Disassembly	16
16	Disposal	16
17	Returns	16
18	Declaration of conformity in accordance with 2014/35/EU (Low Voltage Directive) and 2014/30/ EU (EMC Directive)	18
19	EU Declaration of conformity in accordance with 2014/34/EU (ATEX)	19

1 General information

1.1 Information

- The descriptions and instructions apply to the standard versions. For special versions not described in this document the basic information contained herein applies in combination with any additional special documentation.
- Correct installation, operation, maintenance and repair work ensure faultless operation of the product.
- Should there be any doubts or misunderstandings, the German version is the authoritative document.
- Contact us at the address on the last page for staff training information.

1.2 Symbols used

The following symbols are used in this document:

Symbol	Meaning
●	Tasks to be performed
▶	Response(s) to tasks
–	Lists

1.3 Definition of terms

Working medium

The medium that flows through the GEMÜ product.



1.4 Warning notes



Wherever possible, warning notes are organised according to the following scheme:

SIGNAL WORD	
Possible symbol for the specific danger	Type and source of the danger ▶ Possible consequences of non-observance. ● Measures for avoiding danger.

Warning notes are always marked with a signal word and sometimes also with a symbol for the specific danger.





The following signal words and danger levels are used:

 DANGER	
	Imminent danger! ▶ Non-observance can cause death or severe injury.
 WARNING	
	Potentially dangerous situation! ▶ Non-observance can cause death or severe injury.

 CAUTION	
	Potentially dangerous situation! ▶ Non-observance can cause moderate to light injury.

NOTICE	
	Potentially dangerous situation! ▶ Non-observance can cause damage to property.

The following symbols for the specific dangers can be used within a warning note:

Symbol	Meaning
	Danger of explosion
	Risk of electric shock
	Protect against leakage!
	Danger of burning from hot surfaces!

2 Safety information

The safety information in this document refers only to an individual product. Potentially dangerous conditions can arise in combination with other plant components, which need to be considered on the basis of a risk analysis. The operator is responsible for the production of the risk analysis and for compliance with the resulting precautionary measures and regional safety regulations.

The document contains fundamental safety information that must be observed during commissioning, operation and maintenance. Non-compliance with these instructions may cause:

- Personal hazard due to electrical, mechanical and chemical effects.
- Hazard to nearby equipment.
- Failure of important functions.
- Hazard to the environment due to the leakage of dangerous substances.

The safety information does not take into account:

- Unexpected incidents and events, which may occur during installation, operation and maintenance.
- Local safety regulations which must be adhered to by the operator and by any additional installation personnel.

Prior to commissioning:

1. Transport and store the product correctly.
2. Do not paint the screws and plastic parts of the product.
3. Carry out installation and commissioning using trained personnel.
4. Provide adequate training for installation and operating personnel.
5. Ensure that the contents of the document have been fully understood by the responsible personnel.
6. Define the areas of responsibility.
7. Observe the safety data sheets.
8. Observe the safety regulations for the media used.

During operation:

9. Keep this document available at the place of use.
10. Observe the safety information.
11. Operate the product in accordance with this document.
12. Operate the product in accordance with the specifications.
13. Maintain the product correctly.
14. Do not carry out any maintenance work and repairs not described in this document without consulting the manufacturer first.

In cases of uncertainty:

15. Consult the nearest GEMÜ sales office.

3 Product description

3.1 Construction



Item	Name	Materials
1	Plug	PA
2	Coil housing	Standard: PA 6 M12 connection: Duroplast (Epoxyd NU463) ATEX version: PPS
3	Valve body	PBT
	Seal materials	FPM

3.2 Description

The GEMÜ 0322 directly controlled 3/2-way pilot solenoid valve is designed for direct mounting or for modular battery mounting by using clips. The body is made of plastic. The coil is plastic encapsulated.

3.3 Functional description

GEMÜ 0322 is a 3/2-way pilot solenoid valve. GEMÜ 0322 is designed for single mounting (straight through design) or for modular battery mounting of up to 12 valves (by using clips).

3.3.1 Safety function

The fail-safe state is defined as the state where the solenoid valve is de-energized and the valve is returned to the CLOSED position (de-energized).

4 GEMÜ CONEXO

In the corresponding design with CONEXO, this product has an RFID chip for electronic identification purposes. The position of the RFID chip can be seen below. The CONEXO pen helps read out information stored in the RFID chips. The CONEXO app or CONEXO portal is required to view this information.

Installing the RFID chip

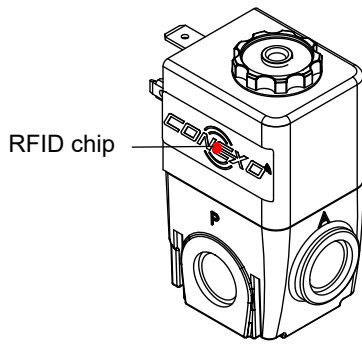

Use of the product is permissible in the following ambient temperature ranges: 0 to +60 °C

For use in potentially explosive areas, the following conditions or operation limits must be observed:

The following special conditions must be complied with:

1. Connection cables and connectors must be protected from damage.
2. Layers of dust > 5 mm must be removed.
3. Warning label "Danger from electrostatic build-up".
4. Warning label "Do not disconnect when live".

5 Correct use

DANGER



Danger of explosion

- ▶ Danger of death or severe injury.
- Only use the product in potentially explosive zones confirmed in the declaration of conformity.

WARNING

Improper use of the product!

- ▶ Risk of severe injury or death
- ▶ Manufacturer liability and guarantee will be void
- Only use the product in accordance with the operating conditions specified in the contract documentation and in this document.

1. Use the product in accordance with the technical data.

The GEMÜ 0322 directly controlled 3/2-way pilot solenoid valve is designed for direct mounting or for modular battery mounting by using clips. The body is made of plastic. The coil is plastic encapsulated.

5.1 Product without ATEX, code 02, 03, 06, 08, 09

The product is not intended for use in potentially explosive areas.

5.2 Product with ATEX, code 01, 04, 05, 07, 11

The product with the ATEX ordering option is intended for use in potentially explosive areas of zone 1 with gases, mists or vapours and zone 22 with combustible dusts in accordance with EU directive 2014/34/EU (ATEX).

The product has the following explosion protection marking:

Gas:  II 2G Ex mb II T4

Dust:  II 2D Ex tD A21 IP65 T130°C

Type examination certificate: PTB 03 ATEX 2018 X

The product has been developed in compliance with the following harmonised standards:

- DIN EN 60079-0:2012+A11:2013
- DIN EN 60079-7:2015
- DIN EN 60079-15:2010
- DIN EN 60079-31:2014

6 Order data

The order data provide an overview of standard configurations.

Please check the availability before ordering. Other configurations available on request.

Order codes

1 Type	Code
Pilot solenoid valve, directly controlled, single mounting/battery mounting	0322

2 DN	Code
DN 2	2

3 Body configuration	Code
Multi-port design	M

4 Connection type	Code
Threaded socket DIN ISO 228	1

5 Valve body/solenoid material	Code
PA, polyamide	74

6 Seal material	Code
FKM	4

7 Control function	Code
Normally closed (NC)	1
Normally open (NO)	2

8 Voltage/Frequency	Code
24 V DC	C1
24 V/50 - 60 Hz	C4
120 V/50 - 60 Hz	G4
230 V/50 - 60 Hz	L4

9 Electrical connection	Code
Plug design A	00
Plug design A, with cable socket, without cable	01
M12 plug, (only NC and 24V DC version)	02
M12 plug, with cable socket, without cable, (only NC and 24V DC version)	03
Plug design A, with cable socket, 3 m cable, encapsulated (only ATEX version)	05
Plug design A with cable socket, without cable, green LED, suppressor diode, (only for 24V DC version)	09

10 Option	Code
Without	00
ATEX (only electrical connection 05, only control function normally closed)	01
Manual override (only control function 1, normally closed)	02
Silencer (only control function 1, normally closed)	03
ATEX, manual override (only electrical connection 05 and for control function 1, normally closed)	04
ATEX silencer (only electrical connection 05 and for control function 1, normally closed)	05
Manual override, silencer (only control function 1, normally closed)	06
ATEX, manual override, silencer (only electrical connection 05 and for control function 1, normally closed)	07
Manual override, silencer with exhaust air throttle (only control function 1, normally closed)	08
Silencer with exhaust air throttle (only control function 1, normally closed)	09
ATEX, manual override, silencer with exhaust air throttle (only electrical connection 05 and for control function 1, normally closed)	11

11 Maximum operating pressure	Code
10 bar	10

12 Type of design	Code
Without	
Media wetted area cleaned to ensure suitability for paint applications, parts sealed in plastic bag	0101

13 CONEXO	Code
Without	
Integrated RFID chip for electronic identification and traceability	C

Order example

Ordering option	Code	Description
1 Type	0322	Pilot solenoid valve, directly controlled, single mounting/battery mounting
2 DN	2	DN 2
3 Body configuration	M	Multi-port design

6 Order data

Ordering option	Code	Description
4 Connection type	1	Threaded socket DIN ISO 228
5 Valve body/solenoid material	74	PA, polyamide
6 Seal material	4	FKM
7 Control function	1	Normally closed (NC)
8 Voltage/Frequency	C1	24 V DC
9 Electrical connection	01	Plug design A, with cable socket, without cable
10 Option	00	Without
11 Maximum operating pressure	10	10 bar
12 Type of design		Without
13 CONEXO		Without

7 Technical data

7.1 Medium

Working medium:	Quality classes to DIN ISO 8573-1
Dust content:	Class 4, max. particle size 15 µm, max. particle density 8 mg/m ³
Oil content:	Class 4, max. oil concentration 5 mg/m ³
Pressure dew point:	Class 4, max. pressure dew point +3 °C



7.2 Temperature

Ambient temperature:	-10 – 50 °C
Media temperature:	-10 – 50 °C

7.3 Pressure

Operating pressure:	0 – 10 bar
Flow rate:	Control function:
	Normally closed (code 1): 70 l/min
	Normally open (code 2): 40 l/min

7.4 Product compliance

Explosion protection:	ATEX (2014/34/EU), order code Option	
ATEX marking:	Gas:  II 2G Ex mb II T4	
	Dust:  II 2D Ex tD A21 IP65 T130°C	
	Type examination certificate: PTB 03 ATEX 2018 X	
SIL:	Product description:	3/2-way pilot solenoid valve GEMÜ 0322
	Device type:	A
	Safety function:	Due to the safety function, the valve is placed in the closed position. For this, the solenoid valve is closed when de-energized (switch position a1).
	HFT (Hardware Fault Tolerance):	0
	MTTR (Mean Time To Restoration):	24 hours

7.5 Mechanical data

Weight:	150 g
Corrosion resistance class:	KBK 2
Isolation class:	F
Protection class:	IP 65
Max. switching frequency:	5 Hz
Switching times:	On: 11 ms
	Off: 20 ms

7.6 Electrical data

Supply voltage:	AC operation: 24 V, 120 V, 230 V
	DC operation: 24 V

Power consumption:	AC operation	
	Normally closed (NC)	Pull in: 11.5 W Hold in: 8.5 W
	Normally open (NO)	6.8 W
	DC operation	
	Normally closed (NC)	4.5 W
	Normally open (NO)	6.8 W

Permissible voltage tolerance: ±10 % to VDE 0580

Duty cycle: Continuous duty

Max. perm. ripple: 20 %

Electrical connection type: Plug design A
Cable diameter: 8 to 10 mm
Optional: M12 plug, cable socket
Optional: ATEX version with 3 m cable (H05V2V2-F 3G1, external Ø 7 mm)

Note: DC coils are used for the AC version of normally open (NO) solenoid valves. For these AC applications with normally open (NO) valves a plug with an integrated bridge rectifier must be used (e.g. GEMÜ 1221 000 Z 0012 230 50/60).

8 Dimensions

8.1 Single valve for direct mounting

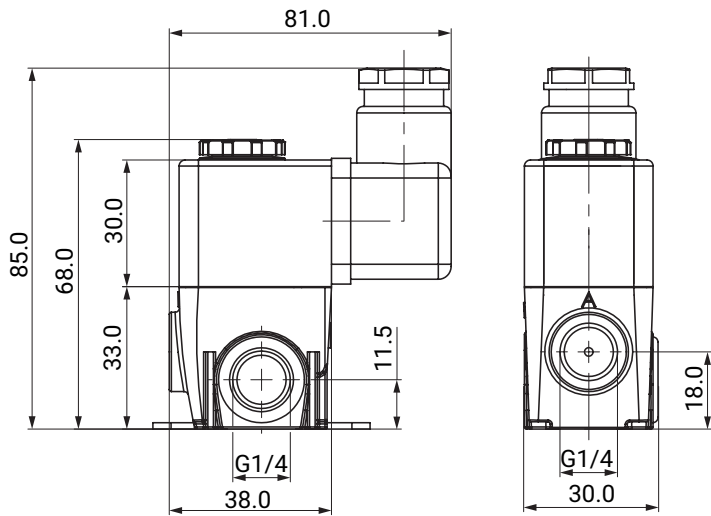

Dimensions in mm

8.2 Battery mounting

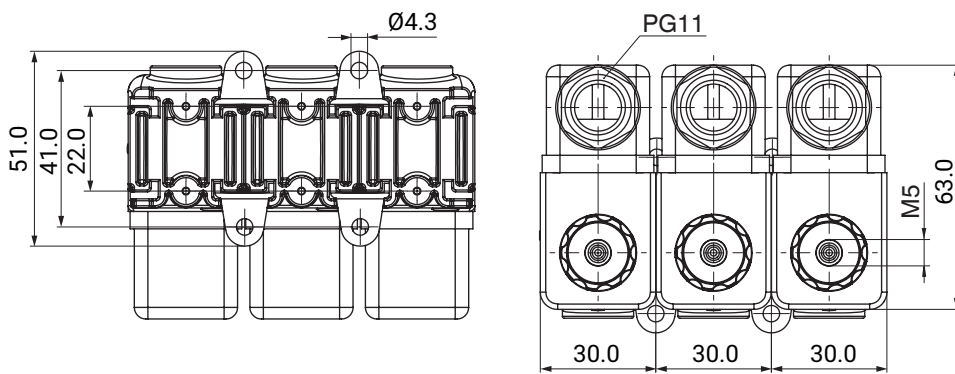

Dimensions in mm

9 Manufacturer's information

9.1 Delivery

- Check that all parts are present and check for any damage immediately upon receipt.

The product's performance is tested at the factory. The scope of delivery is apparent from the dispatch documents and the design from the order number.

9.2 Transport

1. Only transport the product by suitable means. Do not drop. Handle carefully.
2. After the installation dispose of transport packaging material according to relevant local or national disposal regulations / environmental protection laws.

9.3 Storage

1. Store the product free from dust and moisture in its original packaging.
2. Avoid UV rays and direct sunlight.
3. Do not exceed the maximum storage temperature (see chapter "Technical data").
4. Do not store solvents, chemicals, acids, fuels or similar fluids in the same room as GEMÜ products and their spare parts.

10 Installation

⚠ DANGER	
	<p>Risk of electric shock</p> <ul style="list-style-type: none"> ▶ There is a danger of injury or death (if operating voltage is higher than safe extra low voltage)! ● Before performing any work on the GEMÜ product, switch off power and protect circuit from being switched on again.

NOTICE	
ATEX version	
▶ Please observe the relevant EX regulations, in particular EN 60079-14 and EN 50281-1-12, during installation and maintenance .	

Prior to installation:

1. **Check the suitability of the pilot solenoid valve prior to the installation!**
See chapter "Technical data".

10.1 Installation

⚠ WARNING	
The equipment is subject to pressure!	
<ul style="list-style-type: none"> ▶ Risk of severe injury or death ● Depressurize the plant. ● Completely drain the plant. 	

Installation location:

⚠ CAUTION
● Do not apply external force to the pilot solenoid valve.

- Installation position: Optional.
- Manual override and electrical plug must be accessible.
- Direction of the control medium:
from "P" to "A".

Installation:

- Installation work must only be performed by trained personnel.
 - Use appropriate protective gear as specified in plant operator's guidelines.
1. Ensure the suitability of the valve for each respective use. The valve must be appropriate for the piping system operating conditions (medium, medium concentration, temperature and pressure) and the prevailing ambient conditions. Check the technical data of the valve and the materials.
 2. Shut off plant or plant component.
 3. Secure against recommissioning.
 4. Depressurize the plant or plant component.
 5. Completely drain the plant or plant component and allow it to cool down until the temperature is below the media vaporization temperature and cannot cause scalding.
 6. If necessary, correctly decontaminate, rinse and ventilate the plant or plant component.
 7. Carefully remove the caps from the female threads.

10.1.1 Single mounting - GEMÜ 0322

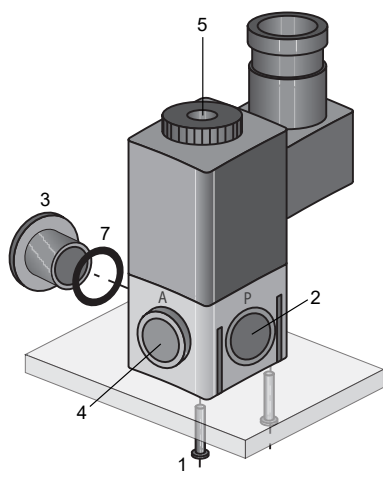

Fig. 1: Single mounting - GEMÜ 0322

1. Fasten the pilot solenoid valve with two machine screws **1** (\varnothing 2.5 mm). Max. screw depth: 10 mm.
2. Connect and seal the pressure inlet tubing to connection "P" **2** (G 1/4). **Only use screwed plugs form A or B, short design, to DIN 3852!**
3. If applicable, connect and seal the exhaust tubing to connection "R" **5** (M5) or mount a silencer.
4. Connect and seal the outlet tubing to connection "A" **4** (G 1/4).
5. Close the open connection "P" with supplied sealing plug **3** and O-ring **7**.
6. All threads must be sealed gas tight.

10.1.2 Battery mounting - GEMÜ 0322

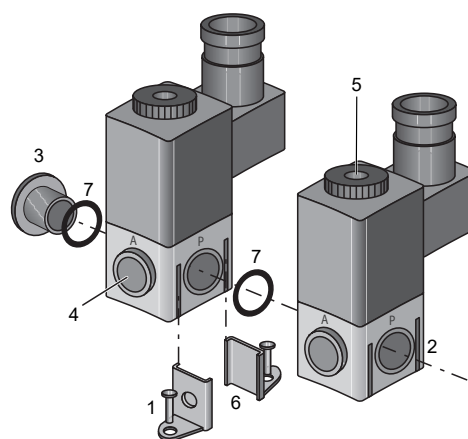

Fig. 2: Battery mounting - GEMÜ 0322

1. Insert O-ring **7** into base recess.
2. Press the pilot solenoid valves together and insert brackets **6** into the respective retainers from below.
3. The brackets **6** hold the pilot solenoid valves together and also serve as fastening elements.
4. Fasten the pilot solenoid valve battery with screws **1**.
5. Connect and seal the pressure inlet tubing to connection "P" **2** (G 1/4). **Only use screwed plugs form A or B, short design, to DIN 3852!**
6. If applicable, connect and seal the exhaust tubing to connection "R" **5** (M5) or mount a silencer.
7. Connect and seal the outlet tubing to connection "A" **4** (G 1/4).
8. Close the open connection "P" with supplied sealing plug **3** and O-ring **7**.
9. All threads must be sealed gas tight.

After the installation:

- Re-attach or reactivate all safety and protective devices.

11 Electrical connection

⚠ DANGER



Risk of electric shock

- ▶ Risk of injury or death (if operating voltage is higher than safe extra low voltage).
- ▶ Electric shock can cause severe burns and fatal injury.
- Work on electrical connections only by qualified trained personnel.
- Disconnect the cable from the power supply before making the electrical connection.
- Connect the protective earth conductor.

⚠ CAUTION

- Power supply varies dependent on the design (see product label).
- Do not bridge terminals!

NOTICE

AC solenoid

- ▶ Tendency to hum.

Required for electrical connection:

- Crosshead screwdriver
- Small flat screw driver

The following note only applies to the ATEX version:

NOTICE

- ▶ Every valve solenoid must have a fuse appropriate for its rated current (max. 3 times rated current in accordance with DIN 41571 or IEC 60127-2-1) or a motor protection switch with short circuit and thermal instantaneous trip (setting to rated current) connected upstream as protection against short circuits. This fuse may be located in the corresponding power supply unit or must be connected separately upstream. The fuse rated voltage must be equal to or greater than the specified nominal voltage of the solenoid. The breaking capacity of the fuse unit must be equal to or greater than the maximum short-circuit current occurring at the site of installation (usually 1500 A).

**Plug design A
(DIN EN 175301-803)**

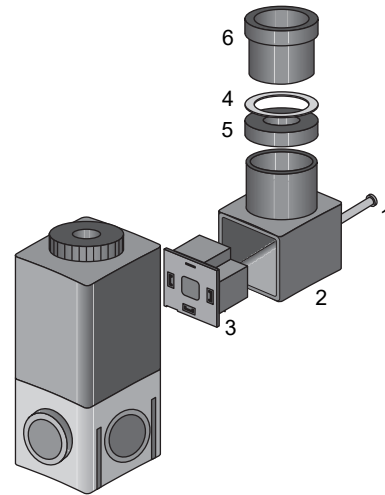

Fig. 3: Electrical connection of plug

1. Disconnect the plant from power supply.
2. Unscrew retaining screw 1.
3. Pull off plug 2 with terminal block 3 from solenoid.
4. Press terminal block 3 carefully out of plug 2.
5. Unscrew cable entry 6.
6. Remove pressure ring 4 and gasket 5.
7. Insert cable through cable entry 6, pressure ring 4, gasket 5 and plug 2.
8. Connect the cable.
9. Insert terminal block 3 again in the plug 2 until it audibly clicks in position.
10. Screw plug 2 to solenoid with retaining screw 1 (max. 0.3 Nm).
11. Close cable entry 6.

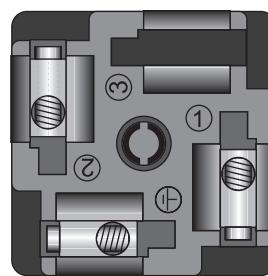



Fig. 4: Rear of terminal block

Item	Name
1	Supply voltage
2	Supply voltage
3	Not connected
	Earth

11.1 Plug design A

11.1.1 Without bridge rectifier (code 00, 01, 05, 09)

Control function 1 (NC), AC/DC voltage
control function 2 (NO), DC voltage

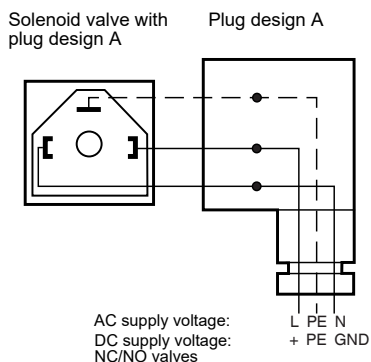

11.1.2 With bridge rectifier (code 06, 10)

Control function 2 (NO), AC voltage

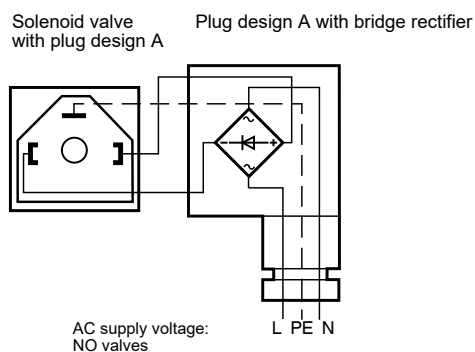

11.1.2.1 ATEX version (DC version)

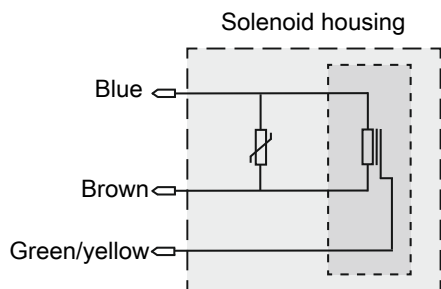

11.1.2.2 ATEX version (AC version)

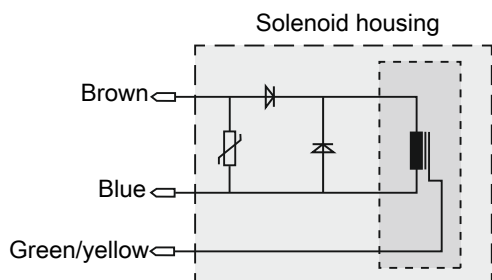

NOTICE

- Electrical connection with the connecting cable integrated into the solenoid coil (cable ends suitable for screw clamp connections) in the safe area or in the potentially explosive area with permissible equipment protected from explosion (e.g. terminal box with type of ignition protection Increased Safety "e" as per EN 50019).
- When screwing in the connecting wires, make sure that the cable ends fit completely into the connecting clamp.
- Connecting wires and cables should not be bent sharply in order to avoid short circuits and breaks.

11.2 M12 plug (code 02, 03)

11.2.1 Pin assignment

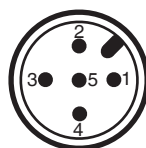

Plug assignment X1 (A-coded)

Pin	Signal name
1	n.c.
2	n.c.
3	Uv, GND
4	Uv, 24 V DC supply voltage
5	n.c.

11.3 Manual override (option)

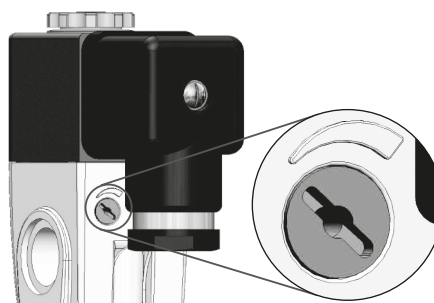

Fig. 5: Manual override

The pilot solenoid valves are equipped with a manual override as an option.

Only actuate the manual override in case of malfunction!

To activate / lock the manual override:

1. Turn red button 90° clockwise with a screw driver.
2. To unlock turn it 90° anti-clockwise with a screwdriver.

12 Commissioning

⚠ CAUTION

Protect against leakage!

- Check the tightness of the media connections prior to commissioning!
- Provide precautionary measures against exceeding the maximum permitted pressures caused by pressure surges.

Prior to cleaning or commissioning the plant:

1. Check the tightness and the function of the pilot solenoid valves.
2. If the plant is new and after repairs blow out the piping system with a fully opened pilot solenoid valve (to remove any harmful foreign matter).

Cleaning:

- The plant operator is responsible for selecting the cleaning material and performing the procedure.

13 Troubleshooting

Error	Error cause	Troubleshooting
The pilot solenoid valve does not open or does not open fully	Power supply not OK	Check power supply and connection, see product label
The pilot solenoid valve does not close or does not close fully	Return spring faulty	Replace the pilot solenoid valve
	Dirt in the valve body	Clean or replace valve body
	Manual override activated	Unlock the manual override as described in "Manual override (optional)"
The pilot solenoid valve does not control correctly	Medium pressure too low / too high	Check medium pressure (see "Technical data")
	Connections leaking	Check the connections (see "Installation")

14 Inspection and maintenance

⚠ WARNING

The equipment is subject to pressure!

- ▶ Risk of severe injury or death
- Depressurize the plant.
- Completely drain the plant.

⚠ WARNING

Danger of burning from hot surfaces!

- ▶ Solenoid coil heats up during operation.
- Allow the solenoid coil and piping to cool down before servicing work.

⚠ CAUTION

- Servicing and maintenance work must only be performed by trained personnel.
- GEMÜ shall assume no liability whatsoever for damage caused by improper handling or third-party actions.
- In case of doubt, contact GEMÜ prior to commissioning.

1. Use appropriate protective gear as specified in plant operator's guidelines.
2. Shut off plant or plant component.
3. Secure against recommissioning.
4. Depressurize the plant or plant component.

NOTICE

- Only use genuine GEMÜ spare parts.
- When ordering spare parts, please state the complete order number of the pilot solenoid valve.

The operator must carry out regular visual examination of the valves dependent on the operating conditions and the potential danger in order to prevent leakage and damage. The valve also has to be checked for wear in the corresponding intervals.

15 Disassembly

Disassembly is performed observing the same precautionary measures as for installation.

1. Disassemble the pilot solenoid valve (see "Installation").
2. Disconnect the electric wire(s) (see "Electrical connection").

16 Disposal

1. Pay attention to adhered residual material and gas diffusion from penetrated media.
2. Dispose of all parts in accordance with the disposal regulations/environmental protection laws.

17 Returns

Legal regulations for the protection of the environment and personnel require that the completed and signed return delivery note is included with the dispatch documents. Returned goods can be processed only when this note is completed. If

no return delivery note is included with the product, GEMÜ cannot process credits or repair work but will dispose of the goods at the operator's expense.

1. Clean the product.
2. Request a return delivery note from GEMÜ.
3. Complete the return delivery note.
4. Send the product with a completed return delivery note to GEMÜ.

18 Declaration of conformity in accordance with 2014/35/EU (Low Voltage Directive) and 2014/30/EU (EMC Directive)

EU Declaration of Conformity
in accordance with 2014/30/EU (EMC Directive) and 2014/35/EU (Low Voltage Directive)

We, GEMÜ Gebr. Müller Apparatebau GmbH & Co. KG
Fritz-Müller-Straße 6-8
74653 Ingelfingen-Criesbach, Germany

declare that the product listed below complies with the directives named above.

Description of the product: GEMÜ 0322

2023-03-01



Joachim Brien
Head of Technical Department

19 EU Declaration of conformity in accordance with 2014/34/EU (ATEX)



EU Declaration of Conformity

in accordance with 2014/34/EU (ATEX)

We, GEMÜ Gebr. Müller Apparatebau GmbH & Co. KG
Fritz-Müller-Straße 6-8
74653 Ingelfingen-Criesbach, Germany

declare that the product listed below complies with the requirements of directive 2014/34/EU for intended use in potentially explosive areas.

Description of the product: Pilot solenoid valve GEMÜ 0322

Explosion protection designation: Gas:  II 2G Ex mb II T4
Dust:  II 2D Ex tD A21 IP65 T130°C
Type examination certificate: PTB 03 ATEX 2018 X

Explanations: For special conditions or operation limits see chapter "Correct use" in the operating instructions.

The Essential Safety and Health Requirements are met by compliance with the standards listed below that are applicable for the above mentioned product:

- DIN EN 60079-0:2012+A11:2013
- DIN EN 60079-7:2015
- DIN EN 60079-15:2010
- DIN EN 60079-31:2014

2023-03-01



Joachim Brien
Head of Technical Department



GEMÜ Gebr. Müller Apparatebau GmbH & Co. KG
Fritz-Müller-Straße 6-8, 74653 Ingelfingen-Criesbach, Germany
Phone +49 (0) 7940 1230 · info@gemue.de
www.gemu-group.com

Subject to alteration

03.2023 | 88660002