

GEMÜ 1240

Electrical position indicator

EN

Operating instructions



All rights including copyrights or industrial property rights are expressly reserved.

Keep the document for future reference.

© GEMÜ Gebr. Müller Apparatebau GmbH & Co. KG
19.09.2023

Contents

1 General information	4
1.1 Information	4
1.2 Symbols used	4
1.3 Warning notes	4
2 Safety information	4
3 Product description	5
3.1 Construction	5
3.2 Description	5
3.3 Function	5
3.4 Product label	5
4 GEMÜ CONEXO	5
5 Correct use	6
6 Order data	7
6.1 Order codes	7
6.2 Order example	7
7 Technical data	8
8 Dimensions	9
9 Manufacturer's information	10
9.1 Delivery	10
9.2 Packaging	10
9.3 Transport	10
9.4 Storage	10
10 Assembly and installation	10
10.1 Preparations for installing the valve (linear actuator)	10
10.4 Threaded adapter assembly (linear actuator)	11
10.5 Assembling the stroke limiter (linear actuator)	12
11 Electrical connection	14
12 Troubleshooting	16
13 Inspection and maintenance	16
14 Disassembly	16
15 Disposal	16
16 Returns	16
17 Declaration of Incorporation according to 2006/42/EC (Machinery Directive)	17
18 Declaration of conformity according to 2014/30/EU (EMC Directive)	18

1 General information

1.1 Information

- The descriptions and instructions apply to the standard versions. For special versions not described in this document the basic information contained herein applies in combination with any additional special documentation.
- Correct installation, operation, maintenance and repair work ensure faultless operation of the product.
- Should there be any doubts or misunderstandings, the German version is the authoritative document.
- Contact us at the address on the last page for staff training information.

1.2 Symbols used

The following symbols are used in this document:

Symbol	Meaning
●	Tasks to be performed
▶	Response(s) to tasks
–	Lists

1.3 Warning notes

Wherever possible, warning notes are organised according to the following scheme:

SIGNAL WORD	
Possible symbol for the specific danger	Type and source of the danger ▶ Possible consequences of non-observance. ● Measures for avoiding danger.





Warning notes are always marked with a signal word and sometimes also with a symbol for the specific danger.

The following signal words and danger levels are used:

⚠ DANGER	
	Imminent danger! ▶ Non-observance can cause death or severe injury.
⚠ WARNING	
	Potentially dangerous situation! ▶ Non-observance can cause death or severe injury.
⚠ CAUTION	
	Potentially dangerous situation! ▶ Non-observance can cause moderate to light injury.

NOTICE	
	Potentially dangerous situation! ▶ Non-observance can cause damage to property.

The following symbols for the specific dangers can be used within a warning note:

Symbol	Meaning
	Danger of explosion!
	Danger of explosion
	Electric shock by high voltage
	Hazard information!

2 Safety information

The safety information in this document refers only to an individual product. Potentially dangerous conditions can arise in combination with other plant components, which need to be considered on the basis of a risk analysis. The operator is responsible for the production of the risk analysis and for compliance with the resulting precautionary measures and regional safety regulations.

The document contains fundamental safety information that must be observed during commissioning, operation and maintenance. Non-compliance with these instructions may cause:

- Personal hazard due to electrical, mechanical and chemical effects.
- Hazard to nearby equipment.
- Failure of important functions.
- Hazard to the environment due to the leakage of dangerous substances.

The safety information does not take into account:

- Unexpected incidents and events, which may occur during installation, operation and maintenance.
- Local safety regulations which must be adhered to by the operator and by any additional installation personnel.

Prior to commissioning:

1. Transport and store the product correctly.
2. Do not paint the bolts and plastic parts of the product.
3. Carry out installation and commissioning using trained personnel.
4. Provide adequate training for installation and operating personnel.
5. Ensure that the contents of the document have been fully understood by the responsible personnel.
6. Define the areas of responsibility.
7. Observe the safety data sheets.
8. Observe the safety regulations for the media used.

During operation:

9. Keep this document available at the place of use.
10. Observe the safety information.
11. Operate the product in accordance with this document.
12. Operate the product in accordance with the specifications.
13. Maintain the product correctly.
14. Do not carry out any maintenance work and repairs not described in this document without consulting the manufacturer first.

In cases of uncertainty:

15. Consult the nearest GEMÜ sales office.

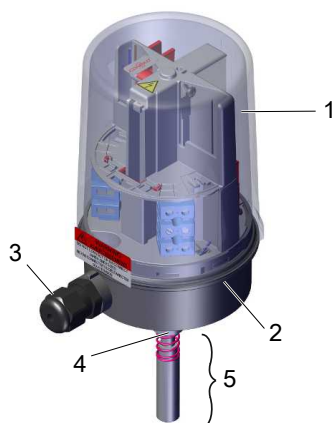
3 Product description**3.1 Construction**

Item	Name	Materials
1	Housing cover	PC
2	Housing base	PPS
3	Electrical connection	SS, PP
4	Adapter piece	SS
5	Mounting kit, valve specific	SS, PP
	Seals	NBR

3.2 Description

The GEMÜ 1240 electrical position indicator is suitable for mounting to pneumatically operated linear actuators. The position of the valve spindle is reliably detected electronically and fed back via microswitches or proximity switches, using play-free and non-positive mounting. The product has been designed specially for valves with a stroke of 5 to 75 mm.

3.3 Function

The GEMÜ 1240 electrical position indicator is used to feed back and verify the position of valves operated with pneumatic linear actuators. The spindle of the electrical position indicator is connected to the valve spindle of the linear actuator through play-free and non-positive mounting and is moved along with the linear movement of the actuator. The cam attached to the spindle then actuates the built-in microswitches or proximity switches, which are used for electronic signal transmission. Depending on the version, the electrical position indicator is equipped with one to two microswitches or proximity switches.

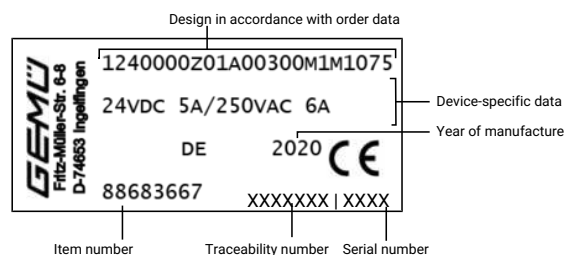
3.4 Product label

The month of manufacture is encoded in the traceability number and can be obtained from GEMÜ. The product was manufactured in Germany.

The manufacturing month is coded under the traceability number and can be requested from GEMÜ. The product was manufactured in Germany.

4 GEMÜ CONEXO**Order variant**

In the corresponding design with CONEXO, this product has an RFID chip (1) for electronic identification purposes. The position of the RFID chip can be seen below. The CONEXO pen helps read out information stored in the RFID chips. The CONEXO app or CONEXO portal is required to display this information.

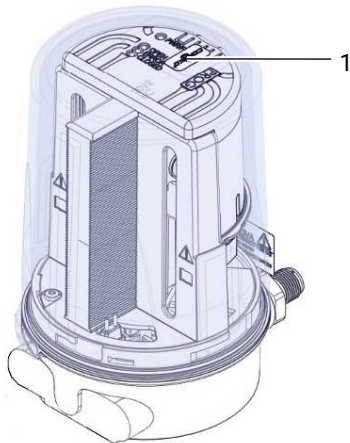

For further information please read the operating instructions for CONEXO products or the CONEXO datasheet.

Products such as the CONEXO app, the CONEXO portal and the CONEXO pen are not included in the scope of delivery and need to be ordered separately.

5 Correct use

DANGER



Danger of explosion!

- ▶ Risk of death or severe injury
- Do **not** use the product in potentially explosive zones.

WARNING

Improper use of the product!

- ▶ Risk of severe injury or death
- ▶ Manufacturer liability and guarantee will be void
- Only use the product in accordance with the operating conditions specified in the contract documentation and in this document.

The product is not intended for use in potentially explosive areas.

The product is designed for fitting to a GEMÜ valve in order to detect the position of linear actuators electrically. It is non-positively connected with the actuator spindle by means of a mounting kit (spring, operating bush). The valve end positions and the integrated travel sensor can be controlled via the electrical connections.

- Use the product in accordance with the technical data.

6 Order data

The order data provide an overview of standard configurations.

Please check the availability before ordering. Other configurations available on request.

Note: A valve specific mounting kit is required for assembly. For designing the mounting kit, the valve type, nominal size, control function and actuator size must be stated.

Order codes

1 Type	Code
Electrical position indicator	1240
2 Fieldbus	Code
Without	000
3 Accessory	Code
Accessory	Z
4 Housing material	Code
PPS base, PC cover	01
5 Device version	Code
Open	A0
Open/closed	AZ
Closed	Z0
6 Electrical connection	Code
M12 plug, 5-pin	01
M16 Skintop cable gland	03
7 Option	Code
Without	00

8 Switch	Code
Change-over contact, microswitch, 24 V DC, 250 V AC Crouzet, V4S, SPDT	M1
Proximity switch, 2-wire, NAMUR P+F, NJ1,5-6,5-15-N-Y180094	N1
Proximity switch, 3-wire, normally open contact, PNP, 10 - 30 V DC Balluff, BES 516-371-SA 16	P1
9 Connection diagram	Code
Microswitch, change-over contact, SPDT	M1
Terminals, NAMUR	N1
3-wire	P1
10 Travel sensor version	Code
Potentiometer, 75 mm length	075
11 CONEXO	Code
Without	
Integrated RFID chip for electronic identification and traceability	C

Order example

Ordering option	Code	Description
1 Type	1240	Electrical position indicator
2 Fieldbus	000	Without
3 Accessory	Z	Accessory
4 Housing material	01	PPS base, PC cover
5 Device version	A0	Open
6 Electrical connection	03	M16 Skintop cable gland
7 Option	00	Without
8 Switch	M1	Change-over contact, microswitch, 24 V DC, 250 V AC Crouzet, V4S, SPDT
9 Connection diagram	M1	Microswitch, change-over contact, SPDT
10 Travel sensor version	075	Potentiometer, 75 mm length
11 CONEXO		Without

7 Technical data**7.1 Temperature**

Ambient temperature: 0 – 60 °C

Storage temperature: -10 – 70 °C

7.2 Product conformity

EMC Directive: 2014/30/EU

Low Voltage Directive: 2014/35/EU

7.3 Mechanical data

Installation position: Optional

Weight: 420 g

Protection class: IP 67

Travel sensor: 5 – 75 mm

7.4 Electrical data

Electrical connection type: M12 cable gland
 Connection thread: M16 x 1.5, WAF 19
 Cable diameter: 4.5 to 10 mm
 Recommended wire cross section: 0.75 mm² x 8 cables

Switch type:

Code M1	Code N1	Code P1
Microswitch, change-over contact, SPDT	2-wire NAMUR	3-wire, normally open contact, PNP

Supply voltage:

Switch		
Code M1	Code N1	Code P1
24 V DC, 250 V AC	8 V DC	10 to 30 V DC

Rated current/
current consumption:

Switch		
Code M1	Code N1	Code P1
for DC: 5 mA to 5 A for AC: 100 mA to 6 A	≥ 3 mA (undamped) ≤ 1 mA (damped)	0–200 mA

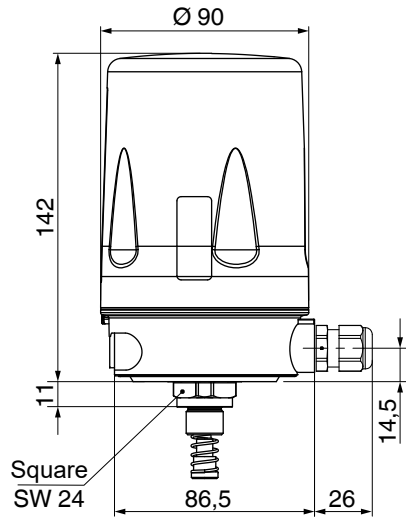
8 Dimensions

Dimensions in mm

9 Manufacturer's information

9.1 Delivery

- Check that all parts are present and check for any damage immediately upon receipt.

The product's performance is tested at the factory. The scope of delivery is apparent from the dispatch documents and the design from the order number.

9.2 Packaging

The product is packaged in a cardboard box which can be recycled as paper.

9.3 Transport

1. Only transport the product by suitable means. Do not drop. Handle carefully.
2. After the installation dispose of transport packaging material according to relevant local or national disposal regulations / environmental protection laws.

9.4 Storage

1. Store the product free from dust and moisture in its original packaging.
2. Avoid UV rays and direct sunlight.
3. Do not exceed the maximum storage temperature (see chapter "Technical data").
4. Do not store solvents, chemicals, acids, fuels or similar fluids in the same room as GEMÜ products and their spare parts.

10 Assembly and installation

1. Observe the national regulations and provisions.
2. Observe the installer provisions.
3. Lay cables securely and protect them from damage.
4. Connect open wire ends in a junction box with protection class IP20 and higher or outside the EX area

10.1 Preparations for installing the valve (linear actuator)

1. Move the actuator **A** into zero position (actuator vented).
2. Remove optical position indicator **2** and / or protective cap **1** from the actuator top.

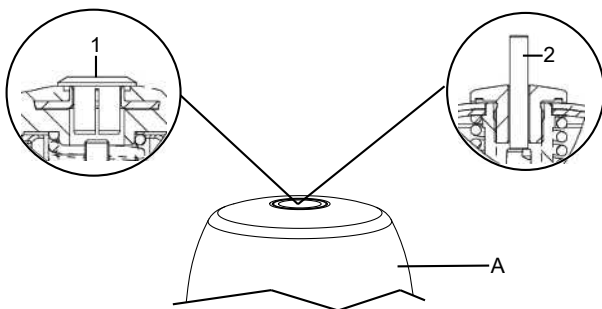

10.2 Information on use in damp conditions

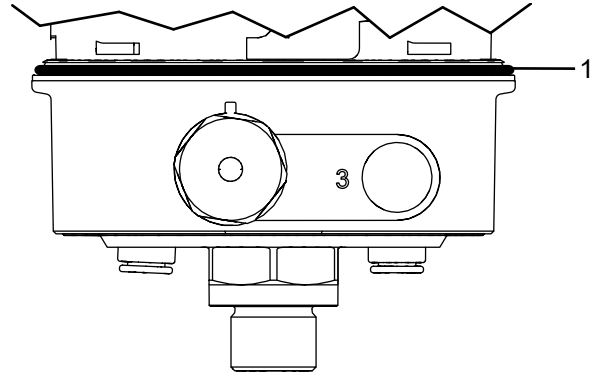

The following information is intended to help when installing and operating the product in damp conditions.

1. Lay cables and pipework so that no condensate or rain water that remains on the pipework / cables can enter the cable glands or plugs of the product.
2. Check that all cable glands or plugs are positioned correctly
3. Check the sealing ring **1** for any damage and correct positioning before tightening the cover.

10.3 Mounting kit assembly

Item	Name	Item	Name
1	Spindle	7	Flange plate
2	Spring	8	Screws
3	Operating bush	9	Pressure disc*
4	Distance piece	10	O-ring*
5	O-ring	11	O-ring*
6	Adapter		

* Included depending on version.

⚠ CAUTION

Pretensioned spring!

- ▶ Damage to the device.
- Slowly release the tension in the spring.

⚠ CAUTION

Do not scratch the spindle!

- ▶ A damaged spindle surface may cause failure of the travel sensor.

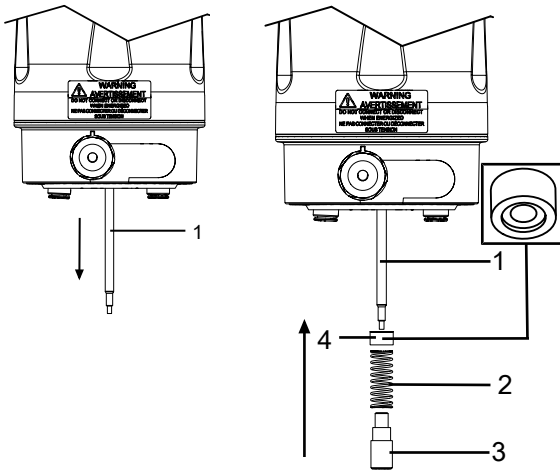

1. Pull out the spindle 1.

2. Align the indentation of the distance piece 4 to the spring and push it over the spindle 1 using the spring 2 and fix it in place using the operating bush 3.

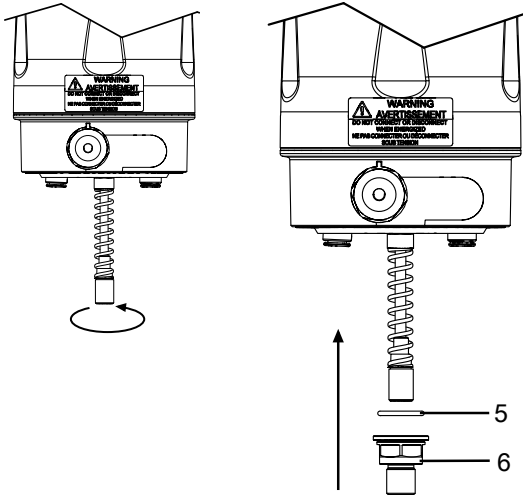

3. Tighten the operating bush 3 by turning it clockwise.

4. Affix the O-ring 5 and the adapter 6.

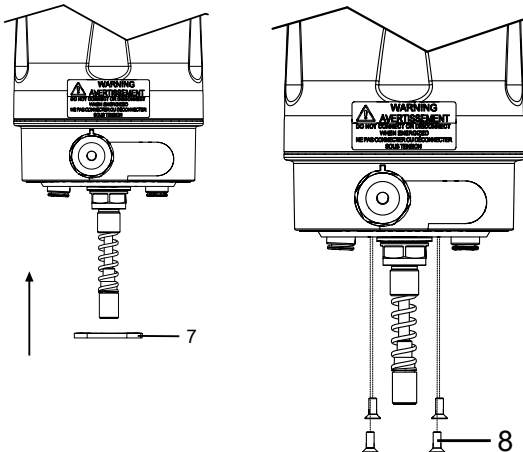

5. Attach the flange plate 7

6. Screw the flange plate on tight using screws 8 (1 – 1.5 Nm).

- Push in the spindle until it pushes against the spring and then slowly release the pressure on the spring.

NOTICE

- ▶ For some valves (e.g. GEMÜ 650 and GEMÜ 687) it is necessary to fit a pressure disc between the threaded adapter and the actuator head. This is included in the required mounting kits, sometimes with an additional O-ring (only GEMÜ 650 with normally open and double-acting control function – code 2+3).
- ▶ If the pressure disc does not have a groove for a seal, this will already be inserted in the groove provided at the adapter opening of the actuator head (e.g. GEMÜ 687 with normally open control function – code 2).

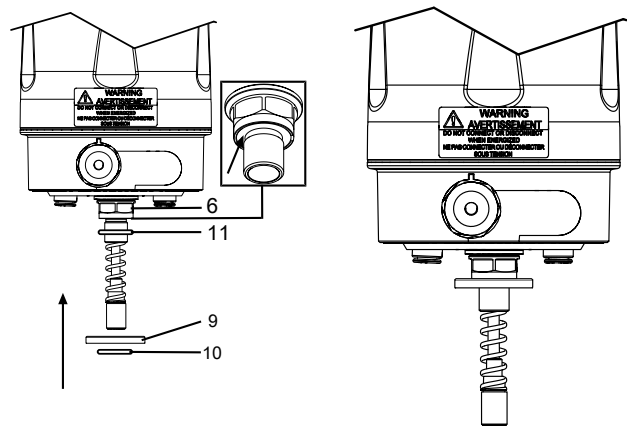

Insert the O-ring 11 (if included) into the corresponding groove on the adapter 6.

If included: Push the pressure disc 9 over the adapter 6 and insert the O-ring 10 in the intended groove of the pressure disc.

10.4 Threaded adapter assembly (linear actuator)

With some mounting kits, it is necessary to install a threaded adapter as well. This threaded adapter is enclosed with the required mounting kits. Valves with a normally open and double acting control function (code 2+3) also include additional O-rings (1+2).

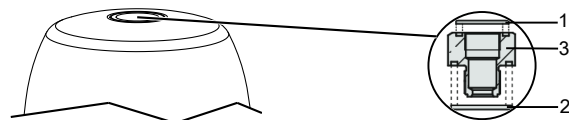

1. Move the actuator to the closed position.
2. Place O-rings 1 and 2 into threaded adapter 3.
3. Screw threaded adapter 3 into the actuator opening as far as it will go and tighten.

10.5 Assembling the stroke limiter (linear actuator)

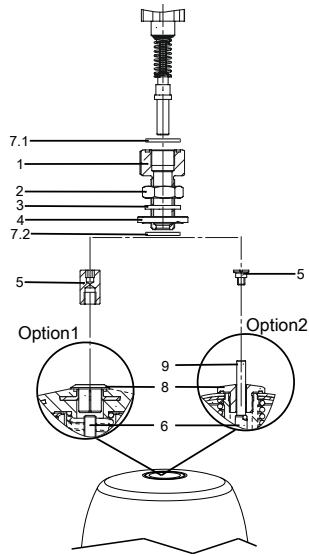

1. Screw distance piece 5 onto/ into actuator spindle 6.
2. Move the actuator to the closed position.
3. Insert the O-ring 7.1 in the stroke limiter 1.
4. Insert the O-ring 7.2 in the washer 4.
5. Screw stroke limiter 1 with nut 2, seal 3 and washer 4 into the actuator opening.
6. Set stroke limiter 1 to the required stroke.
7. Make sure that the minimum stroke is reached.
8. Secure stroke limiter 1 with nut 2.

Key			
1	Stroke limiter	7.1 ¹⁾ 7.2 ¹⁾	O-ring
2	Nut	8	Protective cap
3 ¹⁾	Seal	9	Position indicator
4 ¹⁾	Washer	10	Operating bush
5 ²⁾	Distance piece	11	Spindle
6	Actuator spindle	12	Travel sensor

- 1) Only available for valves with the NO and DA control functions.
- 2) Only included in required mounting kits. The design depends on the valve.

10.6 Assembling and installing the electrical position indicator

⚠ DANGER

Danger of explosion

- ▶ Risk of death or severe injury.
- Do not use the product as a step or foothold.
- Prior to commissioning, ensure that the cover is fully closed and that the housing and the O-ring are not damaged.

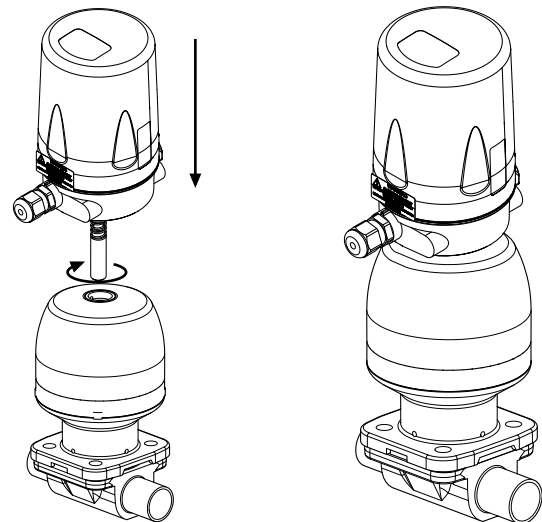

1. Move the actuator into the OPEN position.
2. Place the product as far as it will go into the actuator opening, insert adapter 3 (see chapter 9.3) or stroke limiter 1 (see chapter 9.4) and screw in clockwise against the initial spring tension.
3. Use the spanner flat of the travel sensor to tighten the product.
4. Turn the housing clockwise to align the pneumatic or electrical connections.
5. Set the switch on the product.

⚠ CAUTION

Incorrect installation of the product.

- ▶ Damage to the housing.
- Only tighten the product using the spanner flats provided for this purpose.

10.7 Setting the switching positions

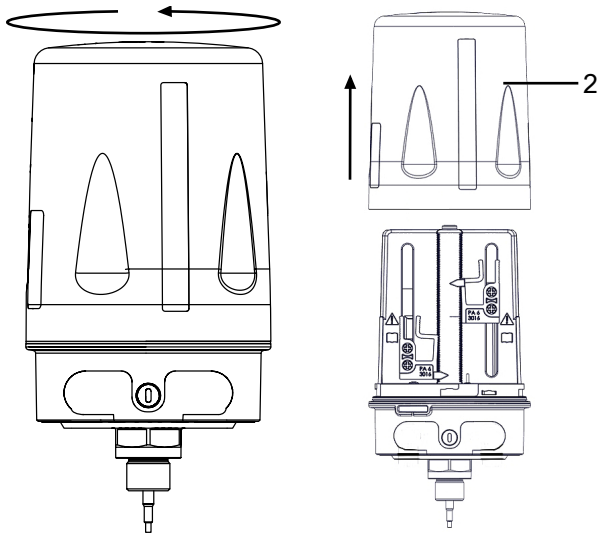

1. Turn the cover anticlockwise to open the bayonet fitting.
2. Remove cover 2.

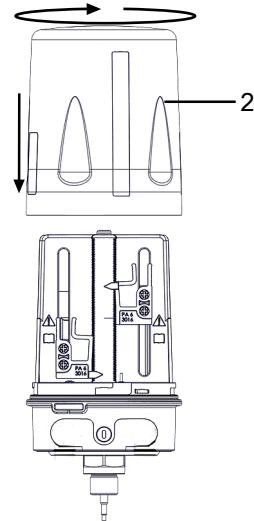

12. After completing the electrical connection, carefully pull the connection cable taut.
13. Make sure that seal 1 is fitted correctly and is not damaged.
14. Put on cover 2 so that the bayonet fitting is inserted correctly and turn cover 2 clockwise.
15. Restore the power supply.
16. To check that everything is working correctly, open and close the valve and observe the signalling.
17. If the settings need to be readjusted, switch off power to the product again and repeat the steps in "Setting the switching positions".

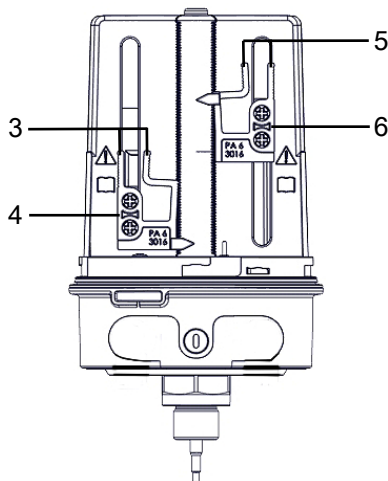

Setting the upper switching position:

3. Move the valve to the OPEN position.
4. Squeeze and hold red levers 3.
5. Push switch 4 on the toothed bar into the desired position.
6. Release red levers 3.
 - ⇒ Switch 4 engages.
 - ⇒ The upper switching position is set.

Setting the lower switching position:

7. Move the valve to the CLOSED position.
8. Squeeze and hold red levers 5.
9. Push switch 6 on the toothed bar into the desired position.
10. Release red levers 5.
 - ⇒ Switch 6 engages.
 - ⇒ The lower switching position is set.

11. Make the electrical connection.

11 Electrical connection

⚠ CAUTION	
	<p>Electric shock by high voltage</p> <ul style="list-style-type: none"> ▶ Danger of injury or death caused by electric shock. ● Power supply varies depending on version. ● Switch off power to the product when working on the product. ● Work on electrical connections only by qualified trained personnel.

11.1 Microswitch, ordering option Connection diagram code M1

11.1.1 Connection diagram

⚠ DANGER	
	<p>Hazard information!</p> <ul style="list-style-type: none"> ▶ The same voltage potential must be used for both limit switches. ▶ High voltages combined with SEL/PELV voltage must not be connected/switched.

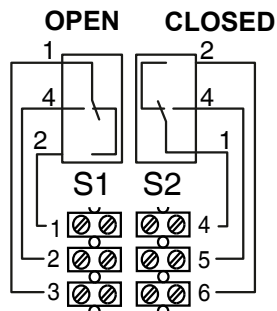

Electrical connection Code 03

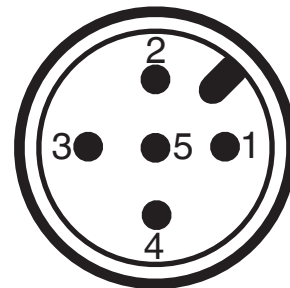

Electrical connection Code 01

Connection	Terminal	Signal	M12 plug
S1 switch OPEN	1	Normally closed	-
	2	Normally open	Pin 1
	3	Common	Pin 2
S2 switch CLOSED	4	Common	Pin 3
	5	Normally open	Pin 4
	6	Normally closed	-

11.2 2-wire NAMUR proximity switch, ordering option Connection diagram code N1

11.2.1 Connection diagram

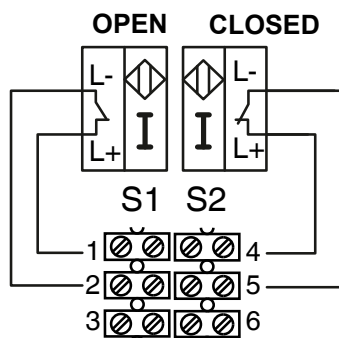

Electrical connection Code 03

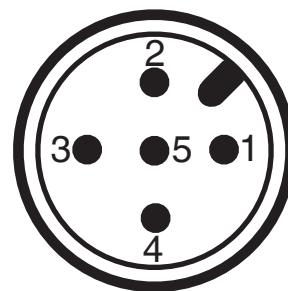

Electrical connection Code 01

Connection	Terminal	Signal	M12 plug
S1 switch OPEN	1	L + 8 V DC	Pin 1
	2	L -	Pin 2
	3	NC	NC
S2 switch CLOSED	4	L + 8 V DC	Pin 3
	5	L -	Pin 4
	6	NC	NC

NC = not connected

11.3 3-wire proximity switch, ordering option Connection diagram code P1

11.3.1 Connection diagram

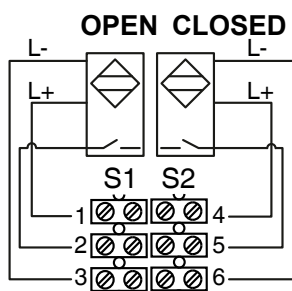

Electrical connection Code 03

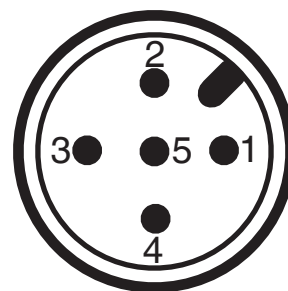

Electrical connection Code 01

Connection	Terminal	Signal	M12 plug
S1 switch OPEN	1	L + 10 to 30 V DC operating voltage	Pin 1
	2	Load	Pin 4
	3	L - GND	Pin 3
S2 switch CLOSED	4	L + 10 to 30 V DC operating voltage	Pin 1
	5	Load	Pin 2
	6	L - GND	Pin 3

12 Troubleshooting

Error	Error cause	Troubleshooting
No stroke	No mounting kit available	Check mounting kit
	Process valve faulty	Replace process valve
	Wrong mounting kit installed	Replace mounting kit
No feedback	Incorrect assembly	Check assembly, wiring and connection
	Switch not set	Set switch
	Wrong mounting kit installed	Replace mounting kit
	Voltage is not connected	Connect voltage
Cover cannot be attached	Sealing ring inserted incorrectly	Insert sealing ring correctly
	Sealing ring damaged	Replace sealing ring
	Cables protruding over the edge of the base	Check the cable routing and shorten the cables if necessary

13 Inspection and maintenance

NOTICE
<p>Exceptional maintenance work!</p> <ul style="list-style-type: none"> ▶ Damage to the GEMÜ product ● Any maintenance work and repairs not described in these operating instructions must not be performed without consulting the manufacturer first.

The operator must carry out regular visual examinations of the products, depending on the operating conditions and the potentially hazardous situations, in order to prevent leakage and damage.

1. Have servicing and maintenance work performed by trained personnel.
2. Wear appropriate protective gear as specified in the plant operator's guidelines.
3. Shut off plant or plant component.
4. Secure the plant or plant component against recommissioning.
5. Depressurize the plant or plant component.
6. Actuate products which are always in the same position four times a year.
7. Carry out inspection and maintenance for products in the potentially explosive area to DIN EN 60079-17.

13.1 Spare parts

No spare parts are available for this product. If it is faulty, please return it to GEMÜ for repair.

13.2 Cleaning the product

- Do **not** clean the product with a high pressure cleaning device.

14 Disassembly

1. Disassemble in reverse order to assembly.
2. Unscrew the electrical wiring.
3. Disassemble the product. Observe warning notes and safety information.

15 Disposal

1. Pay attention to adhered residual material and gas diffusion from penetrated media.
2. Dispose of all parts in accordance with the disposal regulations/environmental protection laws.
3. Dispose of electronic components separately.

16 Returns

Legal regulations for the protection of the environment and personnel require that the completed and signed return delivery note is included with the dispatch documents. Returned goods can be processed only when this note is completed. If no return delivery note is included with the product, GEMÜ cannot process credits or repair work but will dispose of the goods at the operator's expense.

1. Clean the product.
2. Request a return delivery note from GEMÜ.
3. Complete the return delivery note.
4. Send the product with a completed return delivery note to GEMÜ.

17 Declaration of Incorporation according to 2006/42/EC (Machinery Directive)



Declaration of incorporation

according to the EC Machinery Directive 2006/42/EC, Annex II, 1.B for partly completed machinery

We, GEMÜ Gebr. Müller Apparatebau GmbH & Co. KG
Fritz-Müller-Straße 6-8
74653 Ingelfingen-Criesbach, Germany

declare that the following product complies with the essential requirements of the Machinery Directive 2006/42/EC.

Product:	GEMÜ 1240
Product name:	Electrical position indicators
From production date:	10th August 2021
Essential requirements of the Machinery Directive 2006/42/EC	1.1.5, 1.1.6, 1.1.7, 1.3., 1.3.2, 1.3.7, 1.3.8, 1.3.9, 1.5.1, 1.5.2, 1.5.3, 1.5.8, 1.5.14, 1.5.16, 1.6.1, 1.6.3;
Technical standard used in parts:	ISO 12100

We also declare that the specific technical documentation has been compiled in accordance with part B of Annex VII.

GEMÜ 1240, Code M1 (250V AC):

The protection objectives of the Low Voltage Directive 2014/35/EU are complied with in accordance with Annex I, No. 1.5.1 of the Machinery Directive.

The manufacturer, or their authorised representative, undertakes to transmit, in response to a reasoned request, relevant documents on the partly completed machinery to the national authorities. This transmission takes place electronically.

Authorised documentation officer: GEMÜ Gebr. Müller Apparatebau GmbH & Co. KG
Fritz-Müller-Straße 6-8
74653 Ingelfingen-Criesbach, Germany

This does not affect the industrial property rights.

Important note! The valve must only be commissioned in machinery that comply with the provisions of this Directive.

M. Barghoorn
Head of Global Technics

Ingelfingen, 2nd November 2021

18 Declaration of conformity according to 2014/30/EU (EMC Directive)



Declaration of conformity

in accordance with 2014/30/EU (EMC Directive)

We, GEMÜ Gebr. Müller Apparatebau GmbH & Co. KG
Fritz-Müller-Straße 6-8
74653 Ingelfingen-Criesbach, Germany

declare that the product listed below complies with the safety requirements of the EMC Directive 2014/30/EU.

Product:	GEMÜ 1240
Product name:	Electrical position indicators
Technical standard used in parts:	Interference resistance: EN IEC 61000-6-2:2019
	Interference emission: EN IEC 61000-6-4:2019
	Other: EN 61010-1:2010/A1:2019/AC:2019-04 EN IEC 61010-2-201:2018

Pursuant to Article 2 (2 d i) and (2 d ii) of EMC Directive 2014/30/EU, device variants that have such a low electromagnetic emission level due to their physical properties or that contribute to electromagnetic emissions to such a low extent that radio and telecommunication equipment and other equipment can operate as intended, and that operate without unacceptable degradation in the presence electromagnetic disturbance normally consequent upon its intended use, do not fall under this Directive.

Note:
The standards are only applied to products with a motorized actuator.



M. Barghoorn
Head of Global Technics

Ingelfingen, 2nd November 2021



GEMÜ Gebr. Müller Apparatebau GmbH & Co. KG
Fritz-Müller-Straße 6-8, 74653 Ingelfingen-Criesbach, Germany
Phone +49 (0) 7940 1230 · info@gemue.de
www.gemu-group.com

Subject to alteration

09.2023 | 88729239