

## GEMÜ 1242

Electrical position indicator

EN

### Operating instructions



further information  
webcode: GW-1242



All rights including copyrights or industrial property rights are expressly reserved.

Keep the document for future reference.

© GEMÜ Gebr. Müller Apparatebau GmbH & Co. KG  
13.03.2024

## Contents

<b>1 General information</b>	<b>4</b>		
1.1 Information	4		
1.2 Symbols used	4		
1.3 Definition of terms	4		
1.4 Warning notes	4		
<b>2 Safety information</b>	<b>5</b>		
<b>3 Product description</b>	<b>5</b>		
3.1 Construction	5		
3.2 LED displays	6		
3.3 Description	7		
3.4 Function	7		
3.5 Product label	7		
<b>4 GEMÜ CONEXO</b>	<b>7</b>		
<b>5 Correct use</b>	<b>7</b>		
<b>6 Order data</b>	<b>9</b>		
<b>7 Technical data</b>	<b>10</b>		
<b>8 Dimensions</b>	<b>14</b>		
8.1 Size 1	14		
8.2 Size 2	14		
<b>9 Manufacturer's information</b>	<b>15</b>		
9.1 Delivery	15		
9.2 Packaging	15		
9.3 Transport	15		
9.4 Storage	15		
<b>10 Assembly and installation</b>	<b>15</b>		
10.1 Mounting kit assembly	15		
10.2 Installing the electrical position indicator on linear actuators	16		
10.2.2 Threaded adapter assembly (linear actuator)	16		
10.2.3 Assembling the stroke limiter (linear actuator)	17		
10.3 Mounting kit assembly (quarter turn actuator)	18		
10.4 Installing the electrical position indicator on quarter turn actuators	18		
10.4.1 Preparations for assembly to the valve (quarter turn actuator)	18		
<b>11 Electrical connection</b>	<b>19</b>		
11.1 Electrical connection	19		
11.2 Potential equalization – special function X and Y	19		
11.3 24 V / IO-Link, ordering option Fieldbus code 000, electrical connection code 01	20		
11.3.2 Inputs (pin 5)	20		
11.3.3 Outputs (pin 2, 4)	20		
11.4 24 V / IO-Link, ordering option Fieldbus code 000, electrical connection code 02	20		
11.4.2 Inputs (pin 5)	20		
11.4.3 Outputs (pin 2, 4)	20		
11.5 AS-Interface, ordering option Fieldbus, code A2, A3, A4	21		
11.6 DeviceNet, ordering option Fieldbus, code DN	21		
<b>12 Commissioning</b>	<b>21</b>		
12.1 Programming the end positions	22		
		12.1.1 On-site end position programming	22
		12.1.2 Initialization of the end positions via IO-Link	22
		12.1.3 End position programming via DeviceNet	22
		12.1.4 Initialization of end positions via ASI	23
		12.1.5 End position programming via programming input (pin 5)	23
<b>13 Specific data – IO-Link</b>	<b>24</b>		
13.1 Process data	24		
13.2 Parameter overview	24		
13.3 Description of parameter values	26		
13.4 Events	30		
<b>14 Specific data - AS-Interface</b>	<b>30</b>		
14.1 Inputs	30		
14.2 Outputs	30		
14.3 Switch point parameters	31		
14.4 Error analysis	32		
<b>15 Specific data - DeviceNet</b>	<b>32</b>		
15.1 General data	32		
15.2 Net topology - DeviceNet system	32		
15.3 Inputs	33		
15.4 Outputs	33		
15.5 Parameter overview	33		
<b>16 Troubleshooting</b>	<b>36</b>		
<b>17 Inspection and maintenance</b>	<b>36</b>		
<b>18 Disassembly</b>	<b>37</b>		
<b>19 Disposal</b>	<b>37</b>		
<b>20 Returns</b>	<b>37</b>		
<b>21 Declaration of Incorporation according to 2006/42/EC (Machinery Directive)</b>	<b>38</b>		
<b>22 Declaration of conformity according to 2014/30/EU (EMC Directive)</b>	<b>39</b>		
<b>23 Declaration of Conformity in accordance with 2014/34/EU (ATEX)</b>	<b>40</b>		

## 1 General information

### 1.1 Information

- The descriptions and instructions apply to the standard versions. For special versions not described in this document the basic information contained herein applies in combination with any additional special documentation.
- Correct installation, operation, maintenance and repair work ensure faultless operation of the product.
- Should there be any doubts or misunderstandings, the German version is the authoritative document.
- Contact us at the address on the last page for staff training information.

### 1.2 Symbols used

The following symbols are used in this document:

Symbol	Meaning
●	Tasks to be performed
▶	Response(s) to tasks
–	Lists

The following LED symbols are used in the documentation:

Symbol	LED conditions
○	Off
●	Lit (on)
☼	Flashing

### 1.3 Definition of terms

#### Speed-<sup>AP</sup> function

Speed Assembly and Programming, a particularly user-friendly commissioning function for fast mounting, automated setting and initialization of GEMÜ products. Dependent on type, activation uses an external impulse signal or existing precautions on the device (magnetic or housing switch). Changeover to normal operating mode takes place automatically after successful completion.

### 1.4 Warning notes



Wherever possible, warning notes are organised according to the following scheme:



SIGNAL WORD	
Possible symbol for the specific danger	<b>Type and source of the danger</b> <ul style="list-style-type: none"> <li>▶ Possible consequences of non-observance.</li> <li>● Measures for avoiding danger.</li> </ul>

Warning notes are always marked with a signal word and sometimes also with a symbol for the specific danger.

The following signal words and danger levels are used:



 <b>DANGER</b>	
	<b>Imminent danger!</b> <ul style="list-style-type: none"> <li>▶ Non-observance can cause death or severe injury.</li> </ul>

 <b>WARNING</b>	
	<b>Potentially dangerous situation!</b> <ul style="list-style-type: none"> <li>▶ Non-observance can cause death or severe injury.</li> </ul>

 <b>CAUTION</b>	
	<b>Potentially dangerous situation!</b> <ul style="list-style-type: none"> <li>▶ Non-observance can cause moderate to light injury.</li> </ul>

<b>NOTICE</b>	
	<b>Potentially dangerous situation!</b> <ul style="list-style-type: none"> <li>▶ Non-observance can cause damage to property.</li> </ul>

The following symbols for the specific dangers can be used within a warning note:

Symbol	Meaning
	Danger of explosion
	Hazardous situation

## 2 Safety information

The safety information in this document refers only to an individual product. Potentially dangerous conditions can arise in combination with other plant components, which need to be considered on the basis of a risk analysis. The operator is responsible for the production of the risk analysis and for compliance with the resulting precautionary measures and regional safety regulations.

The document contains fundamental safety information that must be observed during commissioning, operation and maintenance. Non-compliance with these instructions may cause:

- Personal hazard due to electrical, mechanical and chemical effects.
- Hazard to nearby equipment.
- Failure of important functions.
- Hazard to the environment due to the leakage of dangerous substances.

The safety information does not take into account:

- Unexpected incidents and events, which may occur during installation, operation and maintenance.
- Local safety regulations which must be adhered to by the operator and by any additional installation personnel.

### Prior to commissioning:

1. Transport and store the product correctly.
2. Do not paint the bolts and plastic parts of the product.
3. Carry out installation and commissioning using trained personnel.
4. Provide adequate training for installation and operating personnel.
5. Ensure that the contents of the document have been fully understood by the responsible personnel.
6. Define the areas of responsibility.
7. Observe the safety data sheets.
8. Observe the safety regulations for the media used.

### During operation:

9. Keep this document available at the place of use.
10. Observe the safety information.
11. Operate the product in accordance with this document.
12. Operate the product in accordance with the specifications.
13. Maintain the product correctly.
14. Do not carry out any maintenance work and repairs not described in this document without consulting the manufacturer first.

### In cases of uncertainty:

15. Consult the nearest GEMÜ sales office.

## 3 Product description

### 3.1 Construction

Size 1, 50 mm

Size 2, 75 mm

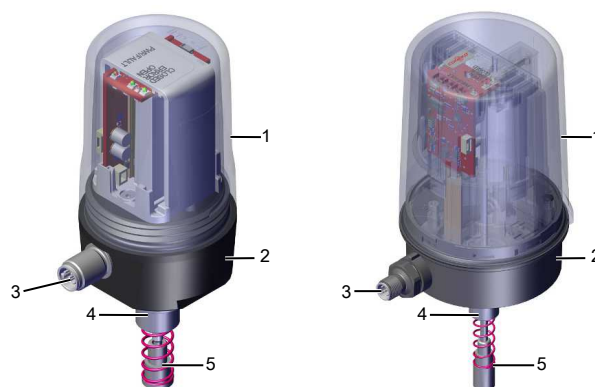

Item	Name	Materials	
		Size 1, 50 mm	Size 2, 75 mm
1	Housing cover – standard version:	PC	PC
2	Housing base	Anodized aluminium or SS	PPS
3	Electrical connection	Threaded piece: SS Insert: PA	Threaded piece: PPS or SS Insert: PA
4	Adapter piece	SS	SS
5	Mounting kit, valve-specific	Valve-specific materials	Valve-specific materials
	Seals	EPDM and NBR	NBR

### 3.2 LED displays

#### 3.2.1 Status LEDs

As well as the electrical position feedback and error analysis, a visual signal is emitted by LEDs that can be seen from above as well as a high visibility LED.

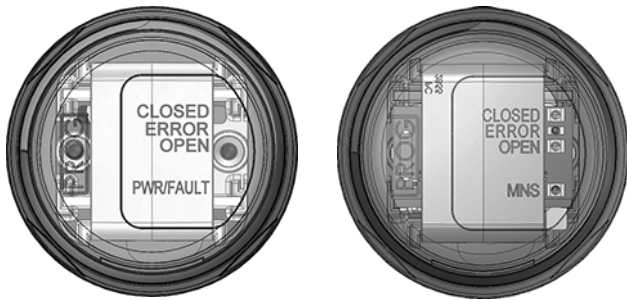

24 V / AS-Interface / IO-Link version      DeviceNet version

LED	Colour		Function
	Standard <sup>1)</sup>	Inversed <sup>2)</sup>	
CLOSED	Green	Orange	Process valve in CLOSED position
ERROR	Red	Red	Error
OPEN	Orange	Green	Process valve in OPEN position
High visibility LED	Green	Orange	Process valve in CLOSED position
	Orange	Green	Process valve in OPEN position
	Alternating green/orange	Alternating green/orange	Programming mode
	Flashes orange	Flashes orange	Error
PWR/FAULT (24 V version, code 000)	Green		Power on
	Red		Supply voltage too low
PWR/FAULT (ASi version, code A2, A3, A4)	Green		Communication active
	Red		Communication error/address 0
	Flashes red		Device error
PWR/FAULT (IO-Link version, code IOL)	Green		SIO operation
	Flashes green		Communication active
	Red		Communication error or supply voltage too low

LED	Colour		Function
	Standard <sup>1)</sup>	Inversed <sup>2)</sup>	
MNS (DeviceNet version, code DN)	Flashes green		Ready for communication
	Green		Communication active
	Flashes red		Communication error
	Red		Communication error, device has disconnected independently from the bus

1) **Option**  
Code 00: Without

2) **Option**  
Code 40: Inversed LED feedback

For order codes see chapter "Order data"

<sup>3)</sup> The flash codes of the PWR/FAULT LED are specified according to AS-Interface and provide feedback about the status of the AS-Interface communication.

<sup>4)</sup> The flash codes of the MNS LEDs are specified according to DeviceNet and give feedback about the status of the DeviceNet communication.

### 3.2.2 LED conditions

Function	CLOSED	ERROR	OPEN	High visibility LED
Valve in OPEN position	○	○	●	●
Valve in CLOSED position	●	○	○	●
Programming mode	☀	○	☀	☀
	OPEN / CLOSED flash alternately			flashes alternately

LED conditions							
●	lit (on)	~	irrelevant	☀	flashes	○	off

### 3.3 Description

The GEMÜ 1242 electrical position indicator is suitable for installation on pneumatically operated linear actuators. The position of the valve spindle is reliably electronically detected and evaluated using play-free and non-positive mounting. Intelligent microprocessor-controlled functions facilitate commissioning and support during operation. The current position of the valve is displayed via high-visibility LEDs and fed back via electrical signals. The GEMÜ 1242 has been specially designed for valves with a stroke of 2 to 46 mm.

### 3.4 Function

The GEMÜ 1242 electrical position indicator shows the position of the valve. When the valve is opened, the spindle in the electrical position indicator moves upwards and indicates that the valve is OPEN using the high visibility LEDs and electrical signals. When the valve is closed, the spring in the mounting kit pushes the spindle in the electrical position indicator downwards and indicates that the valve is CLOSED using the high visibility LEDs and electrical signals.

### 3.5 Product label

<b>GEMÜ</b> Fitz-Müller-Str. 6-8 D-74653 Ingeltingen	Device version	Design in accordance with order data
	1242 DNZ07000100E001050	
	DeviceNet 24VDC 50mA	
	0 - 60°C	
	00 DE	2016
	88470247-8039340 0001	
Item number	Traceability number	Serial number

The manufacturing month is coded under the traceability number and can be requested from GEMÜ. The product was manufactured in Germany.

## 4 GEMÜ CONEXO

### Order variant

In the corresponding design with CONEXO, this product has an RFID chip (1) for electronic identification purposes. The position of the RFID chip can be seen below. The CONEXO pen helps read out information stored in the RFID chips. The CONEXO app or CONEXO portal is required to display this information.

### Installing the RFID chip (1)

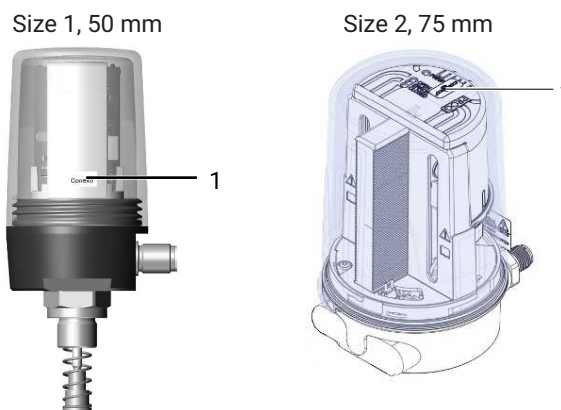

For further information please read the operating instructions for CONEXO products or the CONEXO datasheet.

Products such as the CONEXO app, the CONEXO portal and the CONEXO pen are not included in the scope of delivery and need to be ordered separately.

## 5 Correct use

### ⚠ DANGER



#### Danger of explosion

- ▶ Danger of death or severe injury.
- Only use the product in potentially explosive zones confirmed in the declaration of conformity.

### ⚠ WARNING

#### Improper use of the product!

- ▶ Risk of severe injury or death
- ▶ Manufacturer liability and guarantee will be void.
- Only use the product in accordance with the operating conditions specified in the contract documentation and in this document.

The GEMÜ 1242 is designed to be fitted to a GEMÜ valve in order to detect the position of linear actuators optically and electrically. The product has a microprocessor controlled intelligent position sensor as well as an analogue travel sensor system (potentiometer) and is connected in a force-locking way with the actuator spindle by means of a mounting kit

(spring, operating bush). The valve end positions and the integrated travel sensor can be controlled via the electrical connections.

### 5.1 Product without special function X or Y

The product is not intended for use in potentially explosive areas.

### 5.2 Product with special function Y

The product with special function Y is UL/CSA certified and protected against explosion in accordance with ISA 12.12.01 (see "Technical data").

The product with special function Y can be connected to switches, power supplies, PLC outputs and PLC inputs.

The energy supply must be equipped with a switch or an over-current protective device in the system. The switch or over-current protective device must be placed in a suitable and accessible position and also labelled as an isolating device for the product with special function Y.

The product user is responsible for providing connections that comply with standards, a locking mechanism, cable compatibility and warning signs.

Suitable locking clips must be used to secure the circular connectors against becoming unintentionally loose or being loosened without the use of tools.

Installation, operation and maintenance must only be carried out by qualified trained personnel.

Do not repair the device yourself if it is faulty. Instead, replace it with an equivalent new device. Repairs must only be carried out by the manufacturer!

The device must only be used if its materials are resistant against mechanical and/or chemical influences or corrosion under the respective operating conditions to such a sufficient degree that the explosion protection is not impaired or nullified.

### 5.3 Product with special function X

The product with the special version X order option is intended for use in potentially explosive areas of zone 2 with gases, mists or vapours and zone 22 with combustible dusts in accordance with EU directive 2014/34/EU (ATEX).

The product has the following explosion protection marking:

#### ATEX

Gas:  II 3G Ex ec nC IIC T4 Gc X

Dust:  II 3D Ex tc IIIC T 80 °C Dc X

#### IECEX

Gas:  Ex ec nC IIC T4 Gc

Dust:  Ex tc IIIC T80°C Dc

Certificate: IECEX IBE 18.0029 X

The product has been developed in compliance with the following harmonised standards:

- DIN EN 60079-0:2012+A11:2013
- DIN EN 60079-7+A1:2015-12-31
- DIN EN 60079-15:2010-09-30
- DIN EN 60079-31:2014-07-31

Use of the product is permissible in the following ambient temperature ranges: 0 to +60 °C

#### For use in potentially explosive areas, the following conditions or operation limits must be observed:

Index X is applied to the ATEX marking.

The following special conditions must be complied with:

1. Connection cables and connectors must be protected from damage.
2. Layers of dust > 5 mm must be removed.
3. Warning label "Danger from electrostatic build-up".
4. Warning label "Do not disconnect when live".

The housing must be installed protected from mechanical influences.

RFID chips must not be read out in potentially explosive areas.



## 6 Order data

The order data provide an overview of standard configurations.

Please check the availability before ordering. Other configurations available on request.

Note: A valve specific mounting kit is required for assembly. For designing the mounting kit, the valve type, nominal size, control function and actuator size must be stated.

### Order codes

1 Type	Code
Electrical position indicator	1242

2 Fieldbus	Code
Without, 24 V version, with IO-Link	000
AS-Interface, 31 Slaves, 4E/4A	A2
AS-Interface, 62 Slaves, 4E/3A	A3
AS-Interface, 62 slaves, 8I/8O	A4
DeviceNet	DN

3 Accessory	Code
Accessories	Z

4 Housing material	Code
PPS base, PC cover	01
Stainless steel base, PC cover	07
Aluminium base, PC cover	14

5 Function	Code
Position feedback Open / Closed	00

6 Electrical connection	Code
M12 plug, 5-pin	01

6 Electrical connection	Code
M12 plug, 8-pin	02

7 Option	Code
Without	00
Inversed LED feedback	40

8 Switch	Code
Electronics	E0

9 Connection diagram	Code
M12 plug, 5-pin	01
M12 plug, 8-pin	02

10 Travel length	Code
Potentiometer, 50 mm length	050
Potentiometer, 75 mm length	075

11 Special version	Code
Without	
NEC 500 and UL/CSA approval	Y
ATEX (2014/34/EU), IECEx	X

### Order example

Ordering option	Code	Description
1 Type	1242	Electrical position indicator
2 Fieldbus	000	Without, 24 V version, with IO-Link
3 Accessory	Z	Accessories
4 Housing material	14	Aluminium base, PC cover
5 Function	00	Position feedback Open / Closed
6 Electrical connection	01	M12 plug, 5-pin
7 Option	00	Without
8 Switch	E0	Electronics
9 Connection diagram	01	M12 plug, 5-pin
10 Travel length	050	Potentiometer, 50 mm length
11 Special version		Without

## 7 Technical data

### 7.1 Temperature

**Ambient temperature:** 0 – 60 °C

**Storage temperature:** -10 – 70 °C



### 7.2 Product compliance



**EMC Directive:** 2014/30/EU

Technical standards used:

	24 V
<b>Interference emission</b>	EN 61000-6-3
<b>Interference resistance</b>	EN 61000-6-2
	IO-Link
<b>Interference emission</b>	EN 61000-6-3
<b>Interference resistance</b>	EN 61000-6-2
	AS-Interface
<b>Interference emission</b>	acc. to AS-Interface Spec. 3.0
<b>Interference resistance</b>	acc. to AS-Interface Spec. 3.0
<b>Interference emission / Interference resistance</b>	EN 62026-2:2013 + A1:2019
	DeviceNet
<b>Interference emission</b>	EN 61000-6-3
<b>Interference resistance</b>	EN 61000-6-2

**Explosion protection:** ATEX (2014/34/EU) and IECEx, order code Special version X  
NEC 500 (ISA 12.12.01), order code Special version Y

**ATEX marking:** Gas:  II 3G Ex ec nC IIC T4 Gc X  
Dust:  II 3D Ex tc IIIC T 80 °C Dc X

**IECEx marking:** Gas:  Ex ec nC IIC T4 Gc  
Dust:  Ex tc IIIC T80°C Dc  
Certificate: IECEx IBE 18.0029 X

**NEC marking:** Class I, Division II, Groups C & D, T4

**Approvals:**

	24 V	AS-Interface	IO-Link	DeviceNet
<b>Fieldbus/ communication</b>	-	Travel sensor version 050: AS-Interface certificate no. 125602 Travel sensor version 075: AS-Interface certificate no. 125602	Travel sensor version 050: IO-Link specification V 1.1 Travel sensor version 075: IO-Link specification V 1.1	n.n.

---

<b>SIL:</b>	<b>Product description:</b>	GEMÜ electrical position indicator 1242
	<b>Device type:</b>	B
	<b>Valid software version:</b>	V1.1.X.X
	<b>Safety function:</b>	The fail-safe state is defined as a High (24 V DC) signal at pin 4 (device version 24 V IO-Link), if the current position of the integrated travel sensor is smaller than the switch point CLOSED (default setting 12%).
	<b>HFT (Hardware Fault Tolerance):</b>	0
	<b>MTTR (Mean Time To Restoration):</b>	24 hours
	<b>MTBF (Mean Time Between Failures):</b>	232 years
	Further information, see SIL safety manual	

**7.3 Mechanical data****Installation position:** Optional**Weight:**

	Size 1	Size 2
Aluminium:	320 g	420 g
Stainless steel:	600 g	

**Protection class:**

IP 67

IP NEMA 4X (UL 61010-1, UL 50E), only available as special version code Y

**Travel sensor:**

	Size 1	Size 2
<b>Minimum stroke:</b>	2 mm	5 mm
<b>Maximum stroke:</b>	46 mm	75 mm
<b>Hysteresis:</b>	0.2 mm	0.5 mm
<b>Accuracy:</b>	0.2% Full Scale	

## 7.4 Electrical data

<b>Electrical connection type:</b>	1 x 5-pin M12 plug (A-coded) 1 x 8-pin M12 plug (A-coded)
<b>Supply voltage:</b>	24 V DC (18 to 30 V DC) (according to IO-Link specifications) 26.5 to 31.6 V DC (according to AS-Interface specifications) 11 to 25 V DC (according to DeviceNet specifications)

**Duty cycle:** Continuous duty

**Electrical protection class:** III

**Reverse battery protection:** yes

### Switching characteristic:

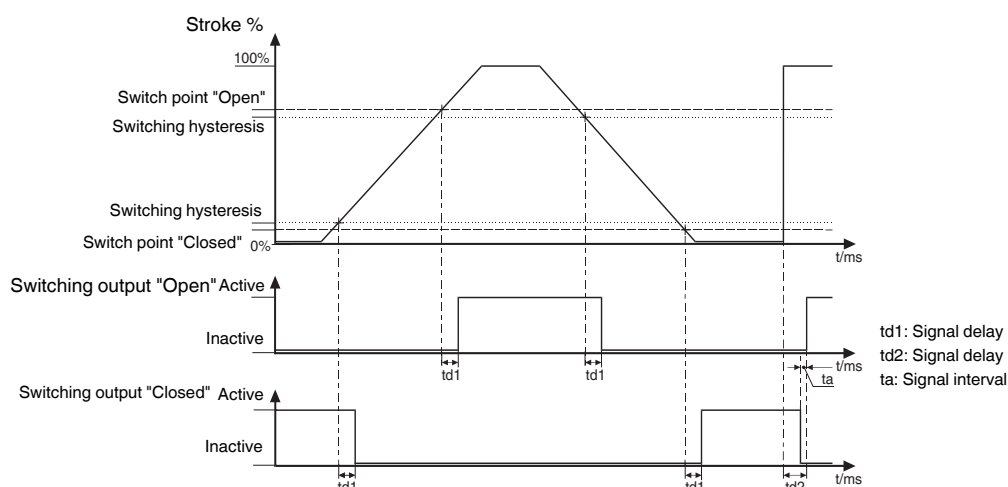

Switch points: The data in percent refers to the programmed stroke, with reference to the lower end position (0%)

### Switch points:

	Size 1	Size 2
<b>Default setting switch point CLOSED</b>	12%	12%
<b>Default setting switch point OPEN</b>	25%	25%
<b>Min. switch point CLOSED</b>	0.8 mm	2 mm
<b>Min. switch point OPEN</b>	0.5 mm	1.25 mm

If the percentage switch points dependent on the programmed stroke are smaller than the permissible min. switch points, the min. switch points apply automatically.

## 8 Dimensions

### 8.1 Size 1

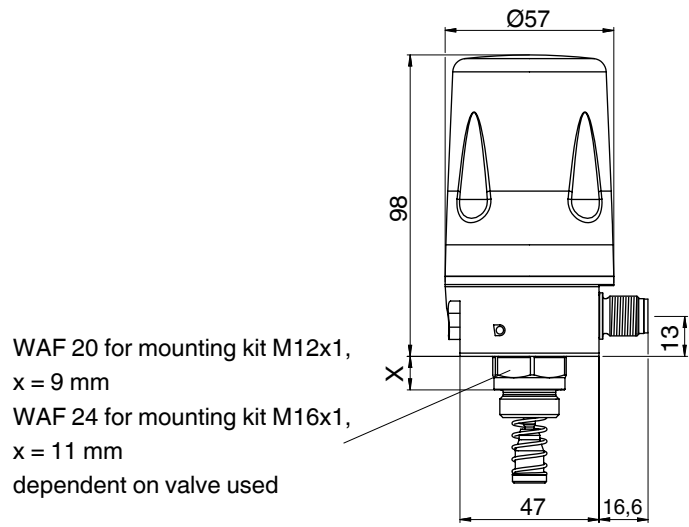

WAF 20 for mounting kit M12x1,  
 $x = 9$  mm  
 WAF 24 for mounting kit M16x1,  
 $x = 11$  mm  
 dependent on valve used

Dimensions in mm

### 8.2 Size 2

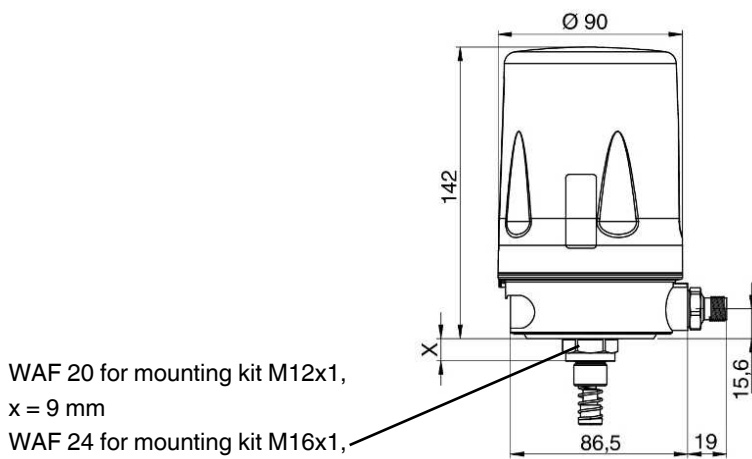

WAF 20 for mounting kit M12x1,  
 $x = 9$  mm  
 WAF 24 for mounting kit M16x1,  
 $x = 11$  mm  
 depending on the valve that is used

Dimensions in mm

## 9 Manufacturer's information

### 9.1 Delivery

- Check that all parts are present and check for any damage immediately upon receipt.

The product's performance is tested at the factory. The scope of delivery is apparent from the dispatch documents and the design from the order number.

### 9.2 Packaging

The product is packaged in a cardboard box which can be recycled as paper.

### 9.3 Transport

1. Only transport the product by suitable means. Do not drop. Handle carefully.
2. After the installation dispose of transport packaging material according to relevant local or national disposal regulations / environmental protection laws.

### 9.4 Storage

1. Store the product free from dust and moisture in its original packaging.
2. Avoid UV rays and direct sunlight.
3. Do not exceed the maximum storage temperature (see chapter "Technical data").
4. Do not store solvents, chemicals, acids, fuels or similar fluids in the same room as GEMÜ products and their spare parts.

## 10 Assembly and installation

### NOTICE

- Pay attention to the information on product labels, in product documentation and EC type examination certificate.
- Connect cable carefully, do not damage individual wires.
- When connecting multiwire or finewire cables, prepare the wire ends.
- Always use suitable pinch tools for pinching wire end ferrules in order to achieve consistent quality.
- Tighten all clamping points, even the ones not being used.

1. Observe the national regulations and provisions.
2. Observe the installer provisions.
3. Protect M12 plugs against electrostatic build-up.
4. Protect M12 plugs against damage.
5. Lay cables securely and protect them from damage.
6. Differential voltage for two intrinsically safe electric circuits: maximum 30 V.
7. Connect open wire ends in a junction box with protection class IP20 and higher or outside the EX area.

### 10.1 Mounting kit assembly

Item	Name	Item	Name
1	Spindle	7	Flange plate
2	Spring	8	Screws
3	Operating bush	9	Pressure disc*
4	Distance piece	10	O-ring*
5	O-ring	11	O-ring*
6	Adapter		

\* Included depending on version.

### ⚠ CAUTION

#### Pretensioned spring!

- ▶ Damage to the device.
- Slowly release the tension in the spring.

### ⚠ CAUTION

#### Do not scratch the spindle!

- ▶ A damaged spindle surface may cause failure of the travel sensor.

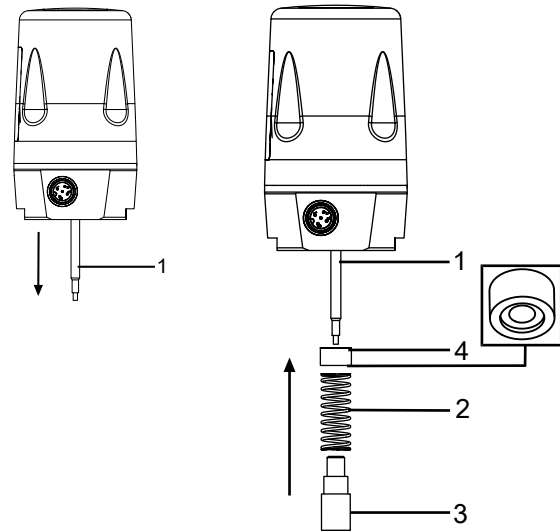

1. Pull out the spindle 1.

2. Align the indentation of the distance piece 4 to the spring and push it over the spindle 1 using the spring 2 and fix it in place using the operating bush 3.

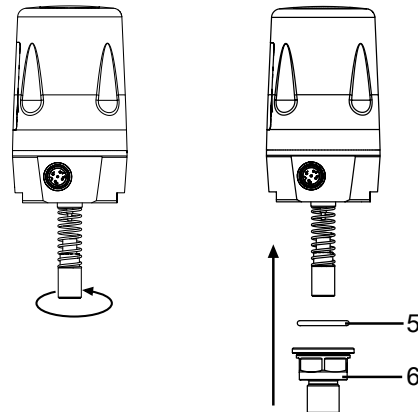

3. Tighten the operating bush 3 by turning it clockwise.
4. Affix the O-ring 5 and the adapter 6.

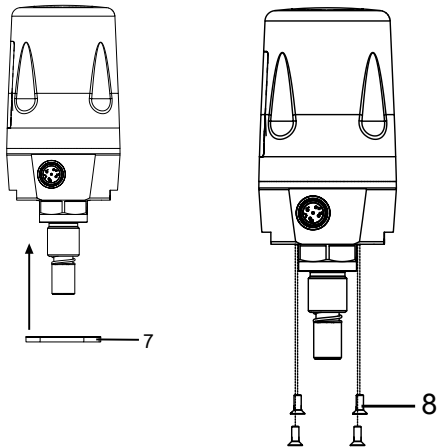

5. Attach the flange 7
6. Screw the flange plate on tight using screws 8 (1–1.5 Nm).

- Push in the spindle until it pushes against the spring and then slowly release the pressure on the spring.

### NOTICE

- ▶ For some valves (e.g. GEMÜ 650 and GEMÜ 687) it is necessary to fit a pressure disc between the threaded adapter and the actuator head. This is included in the required mounting kits, sometimes with an additional O-ring (only GEMÜ 650 with normally open and double acting control function – code 2+3).
- ▶ If the pressure disc does not have a groove for a seal, this will already be inserted in the groove provided at the adapter opening of the actuator head (e.g. GEMÜ 687 with normally open control function – code 2).

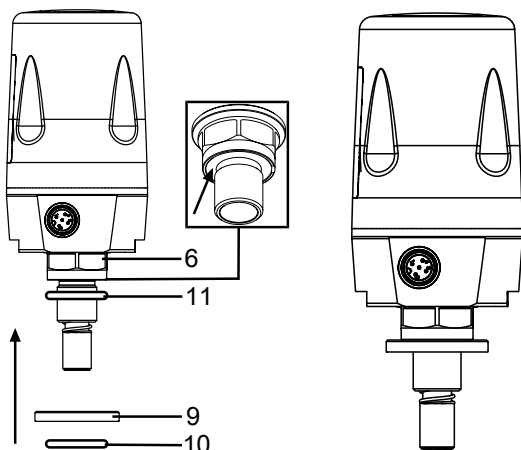

Insert the O-ring 11 (if included) into the corresponding groove on the adapter 6.

If included: Push the pressure disc 9 over the adapter 6 and insert the O-ring 10 in the intended groove of the pressure disc.

## 10.2 Installing the electrical position indicator on linear actuators

### 10.2.1 Preparations for assembly to the valve

1. Move the actuator A into zero position (actuator vented).
2. Remove optical position indicator 2 and / or protective cap 1 from the actuator top.

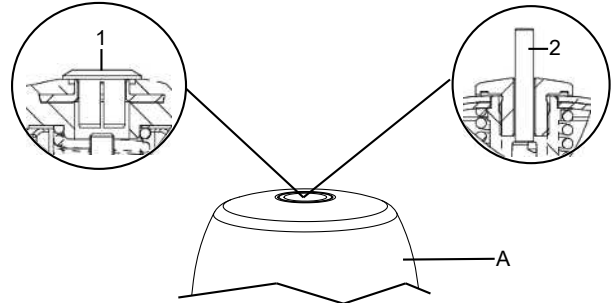

### 10.2.2 Threaded adapter assembly (linear actuator)

With some mounting kits, it is necessary to install a threaded adapter as well. This threaded adapter is enclosed with the required mounting kits. Valves with a normally open and double acting control function (code 2+3) also include additional O-rings (1+2).

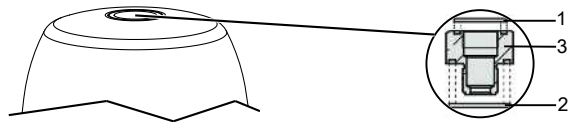

1. Move the actuator to the closed position.
2. Place O-rings 1 and 2 into threaded adapter 3.
3. Screw threaded adapter 3 into the actuator opening as far as it will go and tighten.



**10.2.3 Assembling the stroke limiter (linear actuator)**

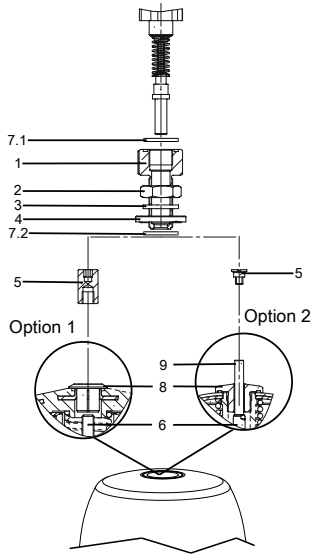

1. Screw distance piece 5 onto/ into actuator spindle 6.
2. Move the actuator to the closed position.
3. Insert the O-ring 7.1 in the stroke limiter 1.
4. Insert the O-ring 7.2 in the washer 4.
5. Screw stroke limiter 1 with nut 2, seal 3 and washer 4 into the actuator opening.
6. Set stroke limiter 1 to the required stroke.
7. Make sure that the minimum stroke is reached.
8. Secure stroke limiter 1 with nut 2.

Key			
1	Stroke limiter	7.1 <sup>1)</sup> 7.2 <sup>1)</sup>	O-ring
2	Nut	8	Protective cap
3 <sup>1)</sup>	Seal	9	Position indicator
4 <sup>1)</sup>	Washer	10	Operating bush
5 <sup>2)</sup>	Distance piece	11	Spindle
6	Actuator spindle	12	Travel sensor

- 1) Only available for valves with the NO and DA control functions.
- 2) Only included in required mounting kits. The design depends on the valve.

**10.2.4 Assembling and installing the electrical position indicator (linear actuator)**

**⚠ DANGER**

**Danger of explosion**

- ▶ Risk of death or severe injury.
- Do not use the product as a step or foothold.
- Prior to commissioning, ensure that the cover is fully closed and that the housing and the O-ring are not damaged.

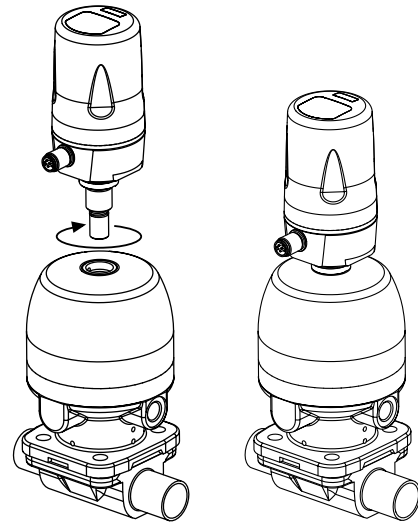

1. Move the actuator to the OPEN position.
2. Guide the product as far as it will go into the actuator opening, the adapter 3 (see "Threaded adapter assembly (linear actuator)", page 16) or the stroke limiter 1 (see "Assembling the stroke limiter (linear actuator)", page 17), and screw it in clockwise against the initial spring tension.
3. Use the spanner flat of the travel sensor to tighten the product.
4. Turn the housing clockwise to align the pneumatic or electrical connections.
5. Initialize the product.

**⚠ CAUTION**

**Incorrect installation of the product.**

- ▶ Damage to the housing.
- Only tighten the product using the spanner flats provided for this purpose.

**NOTICE**

**Wrong mounting kit**

- ▶ If no initial spring tension can be felt, it may be the case that the wrong mounting kit with too short an operating bush has been used.
- ▶ If the spring locks and the positioner cannot be correctly mounted on the valve, it may be the case that the wrong mounting kit with too long an operating bush has been used or that a required adapter has not been used.
- In both cases, check that the mounting kit parts are being used correctly and in their entirety.

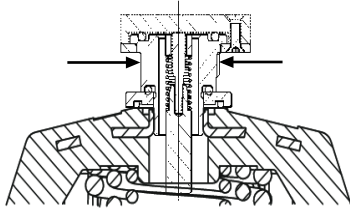

6. The product with mounting kit is fully assembled.

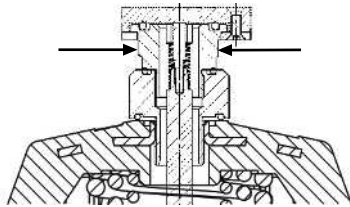

7. The product with mounting kit and adapter is fully assembled.

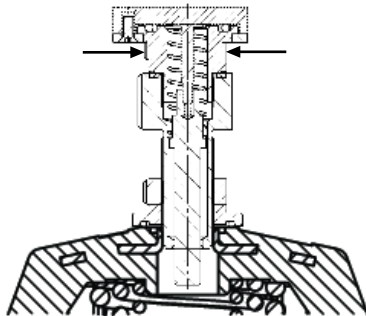

8. The product with mounting kit and stroke limiter is fully assembled.

**10.3 Mounting kit assembly (quarter turn actuator)**

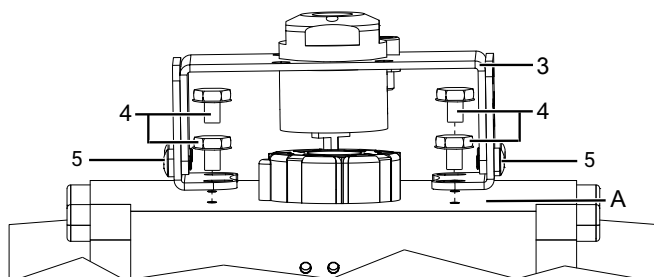

1. Adjust the mounting bracket to the required borehole pattern.

⇒ To do this, loosen the side screws **5** and set the retaining feet onto the thread of the actuator, and install it using screws **4**.

2. Secure the bracket **3** to the retaining feet as shown. In doing so, the tap shaft must sit free of play in the shaft of the actuator.

**10.4 Installing the electrical position indicator on quarter turn actuators**

**10.4.1 Preparations for assembly to the valve (quarter turn actuator)**

1. Move the actuator **A** into zero position (actuator vented).

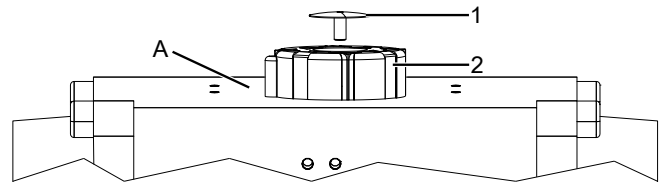

2. Remove the screw **1** from the trigger cam **2**.

**10.4.2 Contents of PTAZ mounting kit for quarter turn actuator**

The PTAZ mounting kit contains the following items:

Item
PTAZ adapter
PTAZ mounting kit
Flange plate
O-ring
Screws (4x)
Adapter (M16x1)
Operating bush
Compression spring

### 10.4.3 NAMUR sizes, quarter turn actuator, PTAZ

The following borehole patterns are available:

80 x 30 x 20
80 x 30 x 30
130 x 30 x 30
130 x 30 x 50

### 10.4.4 Assembling and installing the electrical position indicator (quarter turn actuator)

#### ⚠ CAUTION

##### Incorrect installation of the product.

- ▶ Damage to the housing.
- Only tighten the product using the spanner flats provided for this purpose.

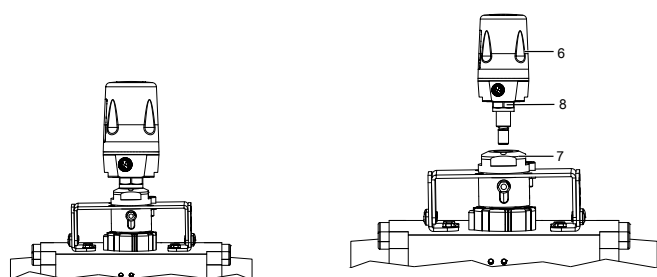

1. Screw the electrical position indicator **6** onto the adapter **7**.
2. Use the spanner flat **8** (WAF 27) of the travel sensor to tighten the electrical position indicator.
3. Turn the housing clockwise to align the pneumatic or electrical connections.
4. Initialize the product.

## 11 Electrical connection

#### ⚠ DANGER



##### Danger of explosion

- ▶ Risk of severe injury or death.
- Danger from sparking. Never disconnect the connection cables when live.

#### ⚠ DANGER



##### Danger of explosion

- ▶ Risk of severe injury or death.
- Do not connect or disconnect the device until the power has been switched off or the area has been classified as non-hazardous.
- The standard version of the product (without special function X or Y) must not be used in potentially explosive zones.
- Danger from sparking. Never disconnect the connection cables when live.

### 11.1 Electrical connection

1. Connect the product in accordance with the pin assignment.

For electrical connection, we recommend the M12 connectors for EX areas from IFM, series EVCxxA.

The M12 plugs may only be assembled, connected and commissioned by trained personnel. The trained personnel must have expertise in types of ignition protection, and regulations and provisions for operating media in EX areas.

2. Securely lay the connection cables or ensure sufficient tension relief.
3. Refer to the technical data and cable gland documentation for details of the wire cross sections.
4. Protect the product and the cables from damage.
5. Only clean the product with an anti-static or damp cloth.
6. Only operate the product when it is fully assembled.

### 11.2 Potential equalization – special function X and Y

#### Connecting the potential equalization device

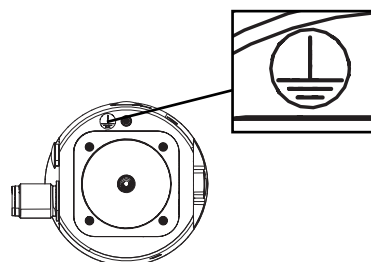

1. Use a screw M4x8 to attach the potential equalization device to the electrical position indicator.
  - ⇒ Potential equalization for metal housings in potentially explosive areas: Minimum 4 mm<sup>2</sup>.
2. Secure the connection against working itself loose.
  - ⇒ Tighten the screw with a torque of 1.8 Nm.

**11.3 24 V / IO-Link, ordering option Fieldbus code 000, electrical connection code 01**

Observe the safety information and general information in the "Electrical connection" section.

**11.3.1 Pin assignment**

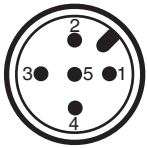

Pin	Signal name
1	U <sub>v</sub> , 24 V DC, supply voltage
2	24 V DC, open end position output
3	U, GND
4	24 V DC, closed end position output, C/Q IO-Link
5	24 V DC, programming input

Pin 5 is highly active. If not used, connect to GND or leave open.

**11.3.2 Inputs (pin 5)**

Input impedance

Min. 27 kΩ

Input voltage

max. 30 V DC

High level

≥ 18 V DC

Low level

≤ 5 V DC

**11.3.3 Outputs (pin 2, 4)**

Internal wiring

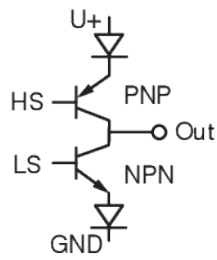

Push-Pull

Max. switching current

± 100 mA

Max. voltage drop V<sub>drop</sub>

3 V DC at 100 mA

Switching voltage

+U<sub>v</sub> - V<sub>drop</sub> push high

-U<sub>v</sub> + V<sub>drop</sub> pull low

**11.4 24 V / IO-Link, ordering option Fieldbus code 000, electrical connection code 02**

Observe the safety information and general information in the "Electrical connection" section.

**11.4.1 Pin assignment**

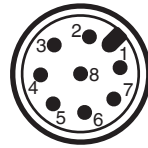

Pin	Signal name
1	U <sub>v</sub> , 24 V DC, supply voltage
2	24 V DC, open end position output
3	U, GND
4	24 V DC, closed end position output
5	24 V DC, programming input
6	n.c.
7	24 V DC, error output
8	n.c.

Pin 5 is highly active. If not used, connect to GND or leave open.

The following errors are indicated via pin 7 (error output): Sensor error, pneumatic error, programming error, internal error

**11.4.2 Inputs (pin 5)**

Input impedance

Min. 27 kΩ

Input voltage

max. 30 V DC

High level

≥ 18 V DC

Low level

≤ 5 V DC

**11.4.3 Outputs (pin 2, 4)**

Internal wiring

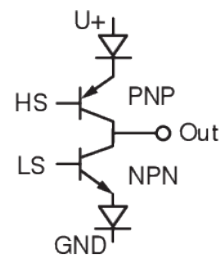

Push-Pull

Max. switching current

± 100 mA

Max. voltage drop V<sub>drop</sub>

3 V DC at 100 mA

Switching voltage

+U<sub>v</sub> - V<sub>drop</sub> push high

-U<sub>v</sub> + V<sub>drop</sub> pull low

### 11.5 AS-Interface, ordering option Fieldbus, code A2, A3, A4

Observe the safety information and general information in the "Electrical connection" section.

#### 11.5.1 Pin assignment



Pin	Signal name
1	AS-Interface +
2	-
3	AS-Interface -
4	n.c.
5	-

Carry out potential equalisation via pre-assembled earthing kit.

Connect yellow/green stranded wire H07 V-K 4.0 on site.

#### 11.5.2 Potential equalisation and electrical connection

The potential equalisation can be established using the following methods:

- Pre-assembled earthing kit for the on-site wiring of the earth via a stranded wire, yellow/green H07 V-K 4.0
- Conductive connection via the mechanically coupled valve fitting to the system earth

The maximum permissible resistance of the potential equalisation connection is defined as  $R \leq 100 \Omega$ . During the plant-specific maintenance cycle, the potential equalisation connection must be checked to ensure that it has been connected correctly and that the maximum resistance has not been exceeded.

#### Procedure

1. Establish the potential equalisation using one of the specified methods.
2. Check the maximum permissible resistance value and check the connections if this is exceeded.
3. Include the check of the potential equalisation in the maintenance cycle.
4. Connect the product in accordance with the pin assignment.

### 11.6 DeviceNet, ordering option Fieldbus, code DN

Observe the safety information and general information in the "Electrical connection" section.

#### 11.6.1 Pin assignment

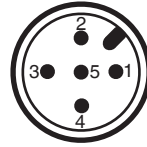

Pin	Signal name
1	Shield
2	V+
3	V-
4	CAN_H
5	CAN_L

## 12 Commissioning

### ⚠ CAUTION



#### Hazardous situation

- ▶ Risk of injury or damage possible.
- For correct commissioning, the product must be calibrated to the process valve by means of the initialization process.
- During this commissioning, the valve is opened and closed. It must therefore be ensured in advance that this does not lead to a dangerous situation.

### NOTICE

#### Incorrect initialization

- Always carry out initialization without operating medium pressure on the process valve. Carry out initialization of the process valve in neutral position (NO/NC).

### NOTICE

- For delivery of the product assembled on a valve at the factory, the complete construction is already ready for operation at a control pressure of 5.5 to 6 bar without operating pressure. A reinitialization is recommended if the plant is operated with a different control pressure or if the mechanical end positions have been changed (e.g. seal replacement on the valve or actuator replacement). The initialization is retained even in the event of voltage cutoff.

**NOTICE**

- For delivery of the product without default setting (e.g. for delivery without valve) initialization must be carried out once for correct operation. This initialization must be repeated every time that the process valve is changed (e.g. seal replacement or actuator replacement).

1. Connect the connection cable tension-free and without any bends or knots.
2. Switch on supply voltage.
3. POWER LED on.
4. Use suitable connectors.
5. Connect the control medium lines tension-free and without any bends or knots.
6. Connect the pneumatic tubes and activate the pneumatic control air supply of max. 7 or 9 bar.
7. Carry out initialisation on-site or via communication interface.

**NOTICE****Initialization is active for an unusually long time**

- ▶ For actuators with a large air volume (filling volume), in some circumstances it can take several minutes until initialization can be completed. Initialization is only unsuccessful if an error message appears with LED signalling.

**12.1 Programming the end positions**

The end positions must be programmed under the following conditions:

- Retrofitting an electrical position indicator
- Replacing the actuator
- Replacing the diaphragm

If electrical position indicators have been fitted to the process valve at the factory, the end positions will already have been programmed.

The end positions can be programmed as follows:

- On-site programming
- Programming input (pin 5)
- Communication interface

When programming via the communication interface, automatic programming is recommended.

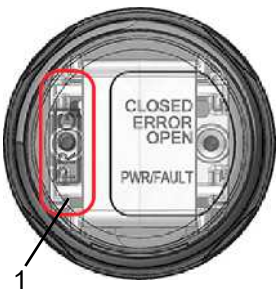
**12.1.1 On-site end position programming**

1. Connect supply voltage.
2. Briefly (>100 ms) hold a magnet (e.g. 1242000ZMA) to the position marked PROG 1 on the housing cover.

- ⇒ OPEN and CLOSED LEDs flash alternately
  - ⇒ High visibility LED flashes alternately green / orange
3. Open valve until end position is reached.
  4. Close valve until end position is reached.
  5. Programming mode is automatically terminated if the valve does not move for 5 seconds.
- ⇒ The end positions are set.

**12.1.2 Initialization of the end positions via IO-Link**

1. Select automatic programming mode (parameter data "Programming mode").
  2. Briefly (>100 ms) activate programming mode (process data "Programming mode").
    - ⇒ OPEN and CLOSED LEDs flash alternately
    - ⇒ High visibility LED flashes alternately green / orange
  3. Open valve until end position is reached.
  4. Close valve until end position is reached.
  5. Programming mode is automatically terminated if the valve does not move for 5 seconds.
- ⇒ The end positions are set.

**12.1.3 End position programming via DeviceNet****Automatic programming mode:**

1. Briefly (>100 ms) set output bit 6 = 1. (automatic programming mode)
  2. Set output bit 6 = 0.
  3. Open valve until end position is reached.
  4. Close valve until end position is reached.
  5. Programming mode is automatically terminated if the valve does not move for 5 seconds.
- ⇒ The end positions are set.

**Manual programming mode:**

6. Set output bit 5 = 1. (manual programming mode)
  7. Open valve until end position is reached.
  8. Close valve until end position is reached.
  9. Set output bit 5 = 0. (electrical position indicator in normal operation)
- ⇒ The end positions are set.

### 12.1.4 Initialization of end positions via ASI

#### 12.1.4.1 A2 version

##### Automatic programming mode:

1. Set DO3 = 1. (automatic programming)
  2. Briefly (>100 ms) set DO2 = 1. (The product is in programming mode)
  3. Set DO3 = 0.
  4. Open the valve until the end position is reached.
  5. Close the valve until the end position is reached.
  6. Electrical position indicator automatically moves to normal mode.
  7. Programming mode is automatically terminated if the valve does not move for 5 seconds.
- ⇒ The end positions are set.
- ⇒ The OPEN, CLOSED and high visibility LEDs light up depending on the product.

##### Manual programming mode:

8. Set DO3 = 0. (manual programming)
  9. Set DO2 = 1. (The product is in programming mode)
  10. Open valve until end position is reached.
  11. Close valve until end position is reached.
  12. Set DO2 = 0. (The product is in normal mode)
- ⇒ The end positions are set.
- ⇒ The OPEN, CLOSED and high visibility LEDs light up depending on the product.

#### 12.1.4.2 A3 version

##### Automatic programming mode:

1. Set DO1 = 1. (automatic programming)
  2. Briefly (>100 ms) set DO2 = 1. (The product is in programming mode)
  3. Open the valve until the end position is reached.
  4. Close the valve until the end position is reached.
  5. Programming mode is automatically terminated if the valve does not move for five seconds.
- ⇒ The end positions are set.
- ⇒ The OPEN, CLOSED and high visibility LEDs light up depending on the product.

##### Manual programming mode:

6. Set DO1 = 0. (manual programming)
  7. Set DO2 = 1. (The product is in programming mode)
  8. Open valve until end position is reached.
  9. Close valve until end position is reached.
  10. Set DO2 = 0. (The product is in normal mode)
- ⇒ The end positions are set.
- ⇒ The OPEN, CLOSED and high visibility LEDs light up depending on the product.

#### 12.1.4.3 A4 version

##### Automatic programming mode:

1. Briefly (>100 ms) set DO2 = 1. (The product is in programming mode)
  2. Open valve until end position is reached.
  3. Close valve until end position is reached.
  4. Programming mode is automatically terminated if the valve does not move for 5 seconds.
- ⇒ The end positions are set.
- ⇒ The OPEN, CLOSED and high visibility LEDs light up depending on the product.

##### Manual programming mode:

5. Set DO1 = 1. (manual programming)
  6. Set DO2 = 1. (The product is in programming mode)
  7. Open valve until end position is reached.
  8. Close valve until end position is reached.
  9. Set DO2 = 0. (The product is in normal operation)
- ⇒ The end positions are set.
- ⇒ The OPEN, CLOSED and high visibility LEDs light up depending on the product.

#### 12.1.5 End position programming via programming input (pin 5)

1. Connect supply voltage.
  2. Briefly connect a 24 V DC signal (>100 ms) to programming input (pin 5).
    - ⇒ OPEN and CLOSED LEDs flash alternately.
    - ⇒ High visibility LED flashes alternately green / orange.
  3. Open valve until end position is reached.
  4. Close valve until end position is reached.
  5. Programming mode is automatically terminated if the valve does not move for 5 seconds.
- ⇒ The end positions are set.

### 13 Specific data – IO-Link

**Physics:** Physics 2 (3-wire design)

**Port configuration:** Port type A

**Transmission rate:** 38400 baud

**Frame type in Operate:** 2.5

**Min. cycle time:** 2.3 ms

**Vendor-ID:** 401

**Device-ID:** 124201

**Product-ID:** 1242 IO-LINK

**ISDU support:** yes

**SIO operation:** yes

**IO-Link specification:** V1.1

**Note for IO-Link:** IODD files can be downloaded via the hyperlinks <https://ioddfinder.io-link.com/%20oder%20www.gemu-group.com>, <https://ioddfinder.io-link.com> or [www.gemu-group.com](http://www.gemu-group.com).

#### 13.1 Process data

##### Device → Master

Name	Bit	Values
Valve position Open	0	0 → Process valve not in Open position
		1 → Process valve in Open position
Valve position Closed	1	0 → Process valve not in Closed position
		1 → Process valve in Closed position
Programming mode	2	0 → Normal operation
		1 → Programming mode

##### Master → Device

Name	Bit	Values
Programming mode	1	0 → Normal operation
		1 → Programming mode
Locate	2	0 → Off
		1 → On

#### 13.2 Parameter overview

### NOTICE

► All IO-Link parameters that contain sub-indexes can also be addressed in bundles via sub-index 0.

Index [Hex]	Su- bindex	Access rights	Parameters	Length	Data type	Default settings	Setting options
0x10	0	ro	Vendor Name	6 bytes	StringT	GEMUE	-
0x12	0	ro	Product Name	13 bytes	StringT	4242 IO-Link	-
0x13	0	ro	Product ID	8 bytes	StringT	4242 IO-LINK	-
0x15	0	ro	Serial number	9 bytes	StringT	0 – 4294967296	-



Index [Hex]	Su-bindex	Access rights	Parameters	Length	Data type	Default settings	Setting options
0x16	0	ro	Hardware Revision	8 bytes	StringT	Rev. xx	-
0x17	0	ro	Firmware Revision	10 bytes	StringT	V x.x.x.x	-
0x50	1	rw	Inversion of LED colours	1 bit	Boolean	0	0 = Standard 1 = Inversed
	2	rw	Inversion of feedback signals	1 bit	Boolean	0	0 = Standard 1 = Inversed
	3	rw	Function of high visibility	3 bit	UIntegerT	3	0 = off 1 = open/closed (33%) 2 = open/closed (66%) 3 = open/closed (100%)
	4	rw	Programming mode	1 bit	Boolean	0	0 = automatic 1 = manual
	5	rw	On-site programming	1 bit	Boolean	0	0 = enabled 1 = disabled
	6	rw	Inversion of outputs	1 bit	Boolean	0	0 = standard 1 = inversed
0x51	1	rw	Switch Point OPEN request	8 bit	UIntegerT	25%	3%–97%
	2	rw	Switch Point CLOSED request	8 bit	UIntegerT	12%	3%–97%
	3	ro	Switch Point OPEN real	8 bit	UIntegerT	25%	Display of values 3%–97%
	4	ro	Switch Point CLOSED real	8 bit	UIntegerT	12%	Display of values 3%–97%
0x52	1	rw	Alarm Stroke reduction OPEN	4 bit	UIntegerT	1	0 = disabled 1 = 25% of Switch Point 2 = 50% of Switch Point 3 = 75% of Switch Point
	2	rw	Alarm Stroke reduction CLOSED	4 bit	UIntegerT	1	0 = disabled 1 = 25% of Switch Point 2 = 50% of Switch Point 3 = 75% of Switch Point
	3	rw	Alarm opening time	8 bit	UIntegerT	0	0 = disabled 1–255 s
	4	rw	Alarm closing time	8 bit	UIntegerT	0	0 = disabled 1–255 s
	5	rw	Valve type	8 bit	UIntegerT	0	0 = unknown 1 = normally closed 2 = normally open
0x53	1	ro	Programmed position OPEN	16 bit	UIntegerT	0	Display of numerical values 0–4092
	2	ro	Programmed position CLOSED	16 bit	UIntegerT	0	
	3	ro	Programmed position STROKE	16 bit	UIntegerT	0	
0x54	1	ro	Last position OPEN	16 bit	UIntegerT	0	
	2	ro	Last position CLOSED	16 bit	UIntegerT	0	
	3	ro	Last position STROKE	16 bit	UIntegerT	0	

Index [Hex]	Su-bindex	Access rights	Parameters	Length	Data type	Default settings	Setting options
0x56	1	rw	Valve cycles user	24 bit	UIntegerT	0	Can be reset to 0, display of numerical values 0–16777215
	2	ro	Valve cycles total	24 bit	UIntegerT	0	Display of numerical values 0–16777215
0x57	1	ro	Counter Powerfail	16 bit	UIntegerT	0	Display of numerical values 0–65535
	2	ro	Counter Power on	16 bit	UIntegerT	0	
	3	ro	Counter Programming	16 bit	UIntegerT	0	
	4	ro	Counter Sensor calibration	16 bit	UIntegerT	0	
	5	ro	Counter Prog error no stroke	16 bit	UIntegerT	0	
	6	ro	Counter Prog error less stroke	16 bit	UIntegerT	0	
	7	ro	Counter Prog error after sensor error	16 bit	UIntegerT	0	
	11	ro	Counter Sensor error OPEN	16 bit	UIntegerT	0	
	12	ro	Counter Sensor error CLOSED	16 bit	UIntegerT	0	
16	ro	Counter Over temperature	16 bit	UIntegerT	0		
0x60	0	ro	Actual AD-value	16 bit	UIntegerT	0	Display of numerical values 0–4092

### 13.3 Description of parameter values

#### Inversion of LED colours

Inversion of the LED colours for the OPEN/CLOSED feedback.

#### Inversion of feedback signals

Inversion of optical and electrical feedback for OPEN/CLOSED feedback.

Travel sensor position	Feedback	
	Standard	Inversed
Travel sensor retracted (valve spindle is up)	OPEN	CLOSED
Travel sensor extended (valve spindle is down)	CLOSED	OPEN

#### Function of high visibility position indicator

The function of the high visibility position indicator can be set to four stages. The setting is used to change the light intensity.

Setting	Function
Stage 1	High visibility position indicator off
Stage 2	High visibility position indicator on (100%)
Stage 3	High visibility position indicator on (33%)
Stage 4	High visibility position indicator on (66%)

Error messages and location function are not affected by the setting and always remain active (100%).

#### Programming mode

Selection of programming mode.

### Local programming

On-site programming can be disabled to prevent unauthorized activation.

Setting	Programming mode	Status
On-site programming enabled	On-site programming	enabled
	Remote programming	enabled
On-site programming disabled	On-site programming	disabled
	Remote programming	enabled

### Threshold open request

Desired switch point setting for OPEN feedback as a percentage of the programmed stroke.

Example: Switch point OPEN 25%, switch point CLOSED 12%

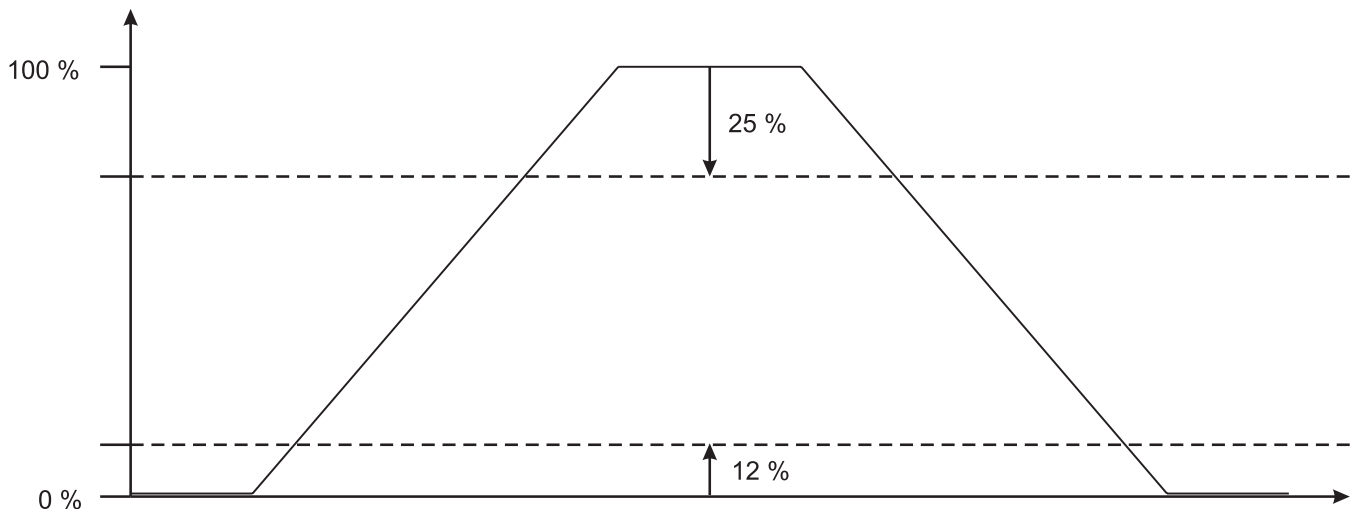

These tolerances enable operational changes e.g. compensation of diaphragm swelling during sterilization to ensure reliable end position feedback.

In the event of overlapping of the set value for CLOSED feedback or if the minimum possible switch point is not met, the maximum possible value is used. The value used can be read out from the parameter "Threshold open real".

### Threshold open real

Value actually used for the switch point for OPEN feedback.

### Threshold closed request

Corresponds to "Threshold open request" but for CLOSED feedback.

### Threshold closed real

Corresponds to "Threshold open real" but for CLOSED feedback.

### Alarm stroke reduction open

Setting for the alarm "Stroke reduction" for OPEN position.

The alarm is triggered if the valve stroke changes beyond the set tolerance in the OPEN position. The alarm is reset automatically as soon as the value returns to within the valid tolerance range. End position feedback takes place independently of the warning as long as the valve is within the set tolerance range for feedback (threshold). If the end position changes, a warning is therefore triggered first before the end position feedback is lost.

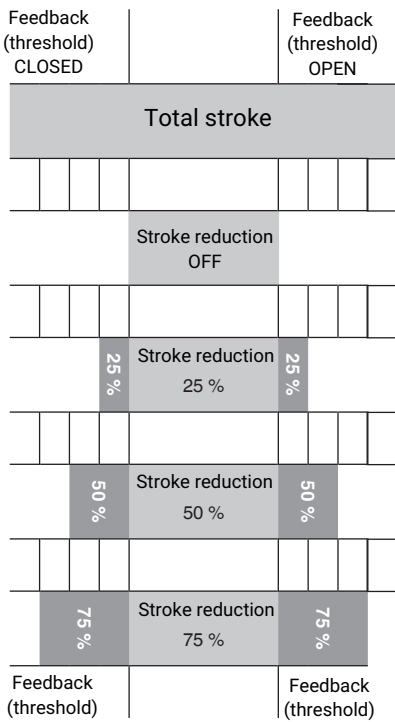

The setting is a percentage of the set switch point tolerance (threshold).

Setting	Function
Off	Warning deactivated
25%	Warning becomes active 25% before loss of end position feedback
50%	Warning becomes active 50% before loss of end position feedback
75%	Warning becomes active 75% before loss of end position feedback

The delay time before the warning occurs corresponds to the time of the parameter **Alarm opening time**.

**NOTICE**

► If the parameter **Alarm opening time** is deactivated (setting 0), the alarm "**Stroke reduction open**" for the **OPEN** position is deactivated.

**Alarm stroke reduction closed**

Corresponds to **Alarm stroke reduction open** but for CLOSED position.

The delay time before the warning occurs corresponds to the time of the parameter **Alarm closing time**.

**NOTICE**

► If the parameter **Alarm closing time** is deactivated (setting 0), the alarm "**Stroke reduction closed**" for the **CLOSED** position is deactivated.

**Programmed position open**

AD value of the OPEN position of the last correctly executed end position programming.

**Programmed position closed**

AD value of the CLOSED position of the last correctly executed end position programming.

**Programmed stroke**

Determined stroke of the linear actuator during the last correctly executed end position programming (in AD values). The change in valve stroke can be calculated in conjunction with the parameter "Last stroke".

**Last position open**

AD value of the last approached OPEN position.

**Last position closed**

AD value of the last approached CLOSED position.

**Last stroke**

Determined stroke of the linear actuator during the last completed switching cycle (in AD values). The change in valve stroke can be calculated in conjunction with the parameter **Programmed stroke**.

**Valve cycles user**

Customer-adjustable switching cycle counter.

Counts the valid switching cycles.

A switching cycle is valid if the valve travels from one defined end position to the other defined end position and returns to the original end position. If an end position is not reached, the switching cycle is invalid and is not counted.

**Valve cycles total**

Factory-set total switching cycle counter (cannot be reset).

Counts the valid switching cycles.

A switching cycle is valid if the valve travels from one defined end position to the other defined end position and returns to the original end position. If an end position is not reached, the switching cycle is invalid and is not counted.

**Counter Powerfail**

Counter power failure.

**Counter Power on**

Power on counter.

**Counter Programming**

Executed end position programming processes counter.

**Counter Sensor calibration**

Executed travel sensor calibrations counter.

**Counter Prog error no stroke**

Programming error counter/no stroke.

**Counter Prog error less stroke**

Programming error counter/stroke < min. stroke.

**Counter Prog error after sensor error**

Programming error counter/after sensor error.

**Counter Sensor error open**

Sensor error counter/OPEN position.

**Counter Sensor error closed**

Sensor error counter/CLOSED position.

**Counter over temperature**

Over-temperature counter.

**Actual AD-value**

Current value of AD converter.

**13.4 Events**

Meaning	Value	Type	Mode
Internal error	0x8CA2	Error	Appear / Disappear
Sensor error in position OPEN	0x8CA4	Error	Appear / Disappear
Sensor error in position CLOSED	0x8CA5	Error	Appear / Disappear
Programming error with no stroke	0x8CA6	Error	Appear / Disappear
Programming error with to less stroke	0x8CA7	Error	Appear / Disappear
Programming error after sensor error	0x8CA8	Error	Appear / Disappear
Not calibrated	0x8CA9	Error	Appear / Disappear
Stroke reduction OPEN	0x8CB5	Warning	Appear / Disappear
Stroke reduction CLOSED	0x8CB6	Warning	Appear / Disappear
Parameter value out of Range	0x8DE0	Notification	Single Shot
Parameter value changed	0x8DE1	Notification	Single Shot

**14 Specific data - AS-Interface**

	A2 version	A3 version	A4 version
<b>AS-Interface specification</b>	3.0; max. 31 slaves	3.0; max. 62 slaves	3.0; max. 62 slaves
<b>AS-Interface profile</b>	S 7.F.E (4I/40)	S 7.A.E (4I/30)	S 7.A.A (8I/80)
<b>I/O configuration</b>	7	7	7
<b>ID code</b>	F	A	A
<b>ID2 code</b>	E	E	A
<b>AS-Interface approval</b>	Size 1: AS-Interface certificate no. 96002		

**14.1 Inputs**

Bit	Default	Function	Version			Logic
			A2	A3	A4	
DI0	0	Indication of OPEN position	X	X	X	0 = process valve not in OPEN position 1 = process valve in OPEN position
DI1	0	Indication of CLOSED position	X	X	X	0 = process valve not in CLOSED position 1 = process valve in CLOSED position
DI2	0	Indication of operating mode	X	X	X	0 = normal operation 1 = programming mode
DI3	0	Error 2	X	X	X	see error analysis
DI4	0	Error 3	-	-	X	
DI5	0	Error 4	-	-	X	
DI6, DI7	not used		-	-	X	
PF	0	Error 1	X	X	X	see error analysis

**14.2 Outputs**

Bit	Default	Function	Version			Logic
			A2	A3	A4	
DO0, DO1	not used		X	X	X	
DO2	0	Setting slave in programming mode	X	X	X	0 = normal operation 1 = programming mode
DO3	0	Programming mode	X	-	-	0 = manual programming 1 = automatic programming

Bit	Default	Function	Version			Logic
			A2	A3	A4	
	0	Function of high visibility position indicator	-	-	X	0 = activated 1 = deactivated
DO4	0	Inversion of feedback signals	-	-	X	0 = standard 1 = inversed
DO5	0	Inversion of LED colours	-	-	X	0 = standard 1 = inversed
DO6	0	Location function	-	-	X	0 = deactivated 1 = activated
DO7	0	On-site programming	-	-	X	0 = enabled 1 = disabled

### 14.3 Switch point parameters

#### Ordering option Fieldbus A2

Parameter				Switch point OPEN [%]	Switch point CLOSED [%]	A2
P3	P2	P1	P0			
0	0	0	0	12	6	X
0	0	0	1	6	6	X
0	0	1	0	3	6	X
0	0	1	1	25	6	X
0	1	0	0	12	3	X
0	1	0	1	6	3	X
0	1	1	0	3	3	X
0	1	1	1	25	3	X
1	0	0	0	12	25	X
1	0	0	1	25	25	X
1	0	1	0	6	25	X
1	0	1	1	3	25	X
1	1	0	0	12	12	X
1	1	0	1	6	12	X
1	1	1	0	3	12	X
1	1	1	1	25	12	X

#### Ordering option Fieldbus A3, A4

Parameter			Switch point OPEN [%]	Switch point CLOSED [%]	A3	A4*
P2	P1	P0				
0	0	0	12	25	X	-
0	0	1	25	25	X	X
0	1	0	6	12	X	-
0	1	1	6	6	X	-
1	0	0	12	12	X	-
1	0	1	12	6	X	-
1	1	0	25	6	X	-
1	1	1	25	12	X	X

\*P0 and P1 are not used

Switch points: The data in percent refer to the programmed stroke, before each end position

### 14.4 Error analysis

#### Ordering option Fieldbus A2, A3

Error	PF (error 1)	DI3 (error 2)
Normal operation	0	0
Internal error	1	0
Programming error	0	1
Sensor error	1	1

#### Ordering option Fieldbus A4

Error	PF (error 1)	DI3 (error 2)	DI4 (error 3)	DI5 (error 4)
Normal operation	0	0	0	0
Stroke reduction OPEN	0	0	0	1
Stroke reduction CLOSED	0	0	1	0
Sensor error	1	1	0	0
Programming error	1	1	0	1
Internal error	1	1	1	0

### 15 Specific data - DeviceNet

#### 15.1 General data

**Communication modes:** Function, Polling, Change of state, Cyclic, Bit strobe

Identity					
Class	Inst.	Attr.	Function	Value	
1h	1h	1h	Vendor ID	869	
		2h	Product Type	43	
		3h	Product Code	1242	
		4h	Rev.	2.2 <sup>1)</sup>	
		5h	Status	Device status according to DeviceNet specifications	
		6h	Series No.	Continuous serial number	
		7h	Name	1242 DN position indicator	

1) Use EDS file in accordance with revision status of the device

Note: Download EDS files from [www.gemu-group.com](http://www.gemu-group.com)

#### 15.2 Net topology - DeviceNet system

To avoid malfunction the trunk cable is fitted with resistors on both sides. The drop cables do not require bus ends.

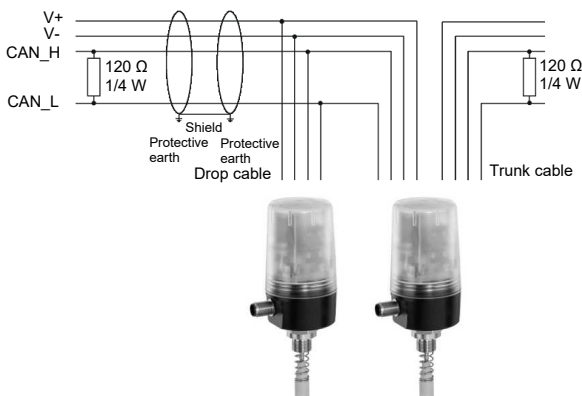



**Maximum cable length**

Baud rate [kBaud]	Trunk cable		Drop cable	
	Thick cable	Thin cable	Max. cable length per drop cable	Max. drop cable accumulated length
125	500 m	100 m	6 m	156 m
250	250 m	100 m	6 m	78 m
500	100 m	100 m	6 m	39 m

**15.3 Inputs**

Bit	Default	Designation	Function	Logic
0, 1	not used			
2	0	Programmingmode	Operating mode	0 = normal operation 1 = programming mode
3	0	Position Closed	CLOSED position	0 = process valve not in CLOSED position 1 = process valve in CLOSED position
4	0	Position Open	OPEN position	0 = process valve not in OPEN position 1 = process valve in OPEN position
5	0	Calibrationmode	Calibration mode	0 = normal operation 1 = calibration mode
6	0	Global warnings	Warning	0 = warning not active 1 = warning active
7	0	Global errors	Error	0 = error not active 1 = error active

As seen from the DeviceNet master, Class 64h, Inst. 1h, Attr. 1h

**15.4 Outputs**

Bit	Default	Designation	Function	Logic
0 ... 2	not used			
3	0	Location function	Location function	0 = location function not active 1 = location function active
4	not used			
5	0	Manual programming	Manual programming mode	0 = manual programming mode not active 1 = manual programming mode active
6	0	Automatic programming	Automatic programming mode:	0 = automatic programming mode not active 1 = automatic programming mode active
7	not used			

As seen from the DeviceNet master, Class 64h, Inst. 1h, Attr. 1h

**15.5 Parameter overview**

Class	Inst.	Attr.	Parameters	Length	Data type	Access	Standard value	Value range
Fh	1h	1h	Inversion of LED colours	1 byte	Boolean	Get/Set	0	0 = standard 1 = inversed
Fh	2h	1h	Inversion of signals	1 byte	Boolean	Get/Set	0	0 = standard 1 = inversed

Class	Inst.	Attr.	Parameters	Length	Data type	Access	Standard value	Value range
Fh	3h	1h	Function of high visibility	1 byte	USINT	Get/Set	3	0 = OFF 1 = 33% 2 = 66% 3 = 100% 4 = Closed 100%; Open OFF 5 = Closed OFF; Open 100%
Fh	4h	1h	On-site programming	1 byte	Boolean	Get/Set	0	0 = enabled 1 = disabled
Fh	5h	1h	Switch Point OPEN request	1 byte	USINT	Get/Set	25	3%–97%
Fh	6h	1h	Switch Point OPEN real	1 byte	USINT	Get	0	Display of values 0%–100%
Fh	7h	1h	Switch Point CLOSED request	1 byte	USINT	Get/Set	12	3%–97%
Fh	8h	1h	Switch Point CLOSED real	1 byte	USINT	Get	0	Display of values 0%–100%
Fh	9h	1h	Alarm stroke reduction OPEN	1 byte	USINT	Get/Set	1	0 = disabled 1 = 25% 2 = 50% 3 = 75%
Fh	Ah	1h	Alarm stroke reduction CLOSED	1 byte	USINT	Get/Set	1	0 = disabled 1 = 25% 2 = 50% 3 = 75%
Fh	Bh	1h	Alarm opening time	1 byte	USINT	Get/Set	0	0–255 (0 = off)
Fh	Ch	1h	Alarm closing time	1 byte	USINT	Get/Set	0	0–255 (0 = off)
Fh	Fh	1h	Programmed position OPEN	2 bytes	UINT	Get	0	Display of numerical values 0–4092
Fh	10h	1h	Programmed position CLOSED	2 bytes	UINT	Get	0	Display of numerical values 0–4092
Fh	11h	1h	Programmed stroke	2 bytes	UINT	Get	0	Display of numerical values 0–4092
Fh	12h	1h	Last position OPEN	2 bytes	UINT	Get	0	Display of numerical values 0–4092
Fh	13h	1h	Last position CLOSED	2 bytes	UINT	Get	0	Display of numerical values 0–4092
Fh	14h	1h	Last stroke	2 bytes	UINT	Get	0	Display of numerical values 0–4092
Fh	15h	1h	Valve position	2 bytes	UINT	Get	0	Display of numerical values 0–4092
Fh	16h	1h	Sensor error	1 byte	USINT	Get	0	0 = Sensor OK 1 = Sensor error position closed 2 = Sensor error position open
Fh	17h	1h	Programming error	1 byte	USINT	Get	1	0 = Programming OK 1 = Not calibrated 2 = No stroke 3 = Stroke < min. stroke 4 = Sensor error position closed 5 = Sensor error position open 6 = Sensor error position closed + open

Class	Inst.	Attr.	Parameters	Length	Data type	Access	Stand- ard value	Value range
Fh	19h	1h	Internal error	1 byte	USINT	Get	0	0 = Device OK 1 = Invalid crc check 2 = Invalid serial number 3 = Memory error
Fh	1Ah	1h	Stroke reduction warning	1 byte	USINT	Get	0	0 = Stroke OK 1 = Stroke reduction position closed 2 = Stroke reduction position open 3 = Stroke reduction position closed + open
Fh	1Bh	1h	Valve cycles user	4 bytes	UDINT	Get/Set	0	Can be reset to 0, display of numerical values 0-429496729
Fh	1Ch	1h	Valve cycles total	4 bytes	UDINT	Get	0	Display of numerical values 0-429496729

## 16 Troubleshooting

### 16.1 LED error message

Function		CLOSED	ERROR	OPEN
Programming error	No stroke			
	Stroke < min. stroke			
	After sensor error			
OPEN / CLOSED flash alternately				
Sensor error	OPEN position			
	CLOSED position			
Pneumatic fault	OPEN position			
	CLOSED position			
	Mid position			
Supply voltage too low				
Internal error				
		OPEN / CLOSED flash simultaneously		

### 16.2 Troubleshooting

Error	Error cause	Troubleshooting
Programming error no stroke	No mounting kit available	Check the mounting kit, re-programme
	Process valve faulty	Replace process valve, re-programme
Programming error stroke < min. stroke	Minimum stroke was not reached (e.g. due to stroke limiter)	Ensure minimum stroke, re-programme
	Shut off diaphragm compressed too much (diaphragm size 8)	Ensure correct compression of the shut off diaphragm, re-programme
Programming error after sensor error	The sensor range was exceeded during the programming procedure. Currently the process valve is in the valid sensor range.	Check the mounting kit, re-programme. Note the maximum stroke (see "Technical data")

Error	Error cause	Troubleshooting
Sensor error CLOSED or OPEN position	Sensor limit exceeded	Check the mounting kit, re-programme. Note the maximum stroke (see "Technical data")
Sensor error CLOSED position	Sensor limit in CLOSED position exceeded	Check the mounting kit, re-programme. Note the maximum stroke (see "Technical data")
Supply voltage too low	Supply voltage < 18 V DC	Ensure supply voltage (see "Technical data")
Internal error	Memory error	Reprogram, if programming cannot be carried out, send the product back
The spring locks during installation	Mounting kit too long	Contact GEMÜ

## 17 Inspection and maintenance

### NOTICE

#### Exceptional maintenance work!

- ▶ Damage to the GEMÜ product
- Any maintenance work and repairs not described in these operating instructions must not be performed without consulting the manufacturer first.

The operator must carry out regular visual examinations of the products, depending on the operating conditions and the potentially hazardous situations, in order to prevent leakage and damage.

1. Have servicing and maintenance work performed by trained personnel.
2. Wear appropriate protective gear as specified in the plant operator's guidelines.
3. Shut off plant or plant component.
4. Secure the plant or plant component against recommissioning.
5. Depressurize the plant or plant component.
6. Actuate products which are always in the same position four times a year.
7. Check whether the housing cover is closed.
8. Carry out inspection and maintenance for products in the potentially explosive area to DIN EN 60079-17.

### 17.1 Spare parts

No spare parts are available for this product. If it is faulty, please return it to GEMÜ for repair.

## 17.2 Cleaning the product

 <b>DANGER</b>	
	<p><b>Danger of explosion</b></p> <ul style="list-style-type: none"> <li>▶ Risk of death or severe injury.</li> <li>● Danger from sparking. Only clean the product with an anti-static or damp cloth.</li> </ul>

- Do **not** clean the product with a high pressure cleaning device.

## 18 Disassembly

1. Disassemble in reverse order to assembly.
2. Unscrew the electrical wiring.
3. Disassemble the product. Observe warning notes and safety information.

## 19 Disposal

1. Pay attention to adhered residual material and gas diffusion from penetrated media.
2. Dispose of all parts in accordance with the disposal regulations/environmental protection laws.

## 20 Returns

Legal regulations for the protection of the environment and personnel require that the completed and signed return delivery note is included with the dispatch documents. Returned goods can be processed only when this note is completed. If no return delivery note is included with the product, GEMÜ cannot process credits or repair work but will dispose of the goods at the operator's expense.

1. Clean the product.
2. Request a return delivery note from GEMÜ.
3. Complete the return delivery note.
4. Send the product with a completed return delivery note to GEMÜ.

## 21 Declaration of Incorporation according to 2006/42/EC (Machinery Directive)



### Declaration of incorporation

according to the EC Machinery Directive 2006/42/EC, Annex II, 1.B for partly completed machinery

We, GEMÜ Gebr. Müller Apparatebau GmbH & Co. KG  
Fritz-Müller-Straße 6-8  
74653 Ingelfingen-Criesbach, Germany

declare that the following product complies with the essential requirements of the Machinery Directive 2006/42/EC.

<b>Product:</b>	GEMÜ 1242
<b>Product name:</b>	Electrical position indicator
<b>From production date:</b>	10th August 2021
<b>Essential requirements of the Machinery Directive 2006/42/EC</b>	1.1.5, 1.1.6, 1.1.7, 1.3., 1.3.2, 1.3.7, 1.3.8, 1.3.9, 1.5.1, 1.5.2, 1.5.3, 1.5.8, 1.5.14, 1.5.16, 1.6.1, 1.6.3;
<b>Technical standard used in parts:</b>	ISO 12100

We also declare that the specific technical documentation has been compiled in accordance with part B of Annex VII.

The manufacturer, or their authorised representative, undertakes to transmit, in response to a reasoned request, relevant documents on the partly completed machinery to the national authorities. This transmission takes place electronically.

Authorised documentation officer: GEMÜ Gebr. Müller Apparatebau GmbH & Co. KG  
Fritz-Müller-Straße 6-8  
74653 Ingelfingen-Criesbach, Germany

This does not affect the industrial property rights.

**Important note! The valve must only be commissioned in machinery that comply with the provisions of this Directive.**



M. Barghoorn  
Head of Global Technics

Ingelfingen, 2nd November 2021

**22 Declaration of conformity according to 2014/30/EU (EMC Directive)**



**EU Declaration of Conformity**  
**in accordance with 2014/30/EU (EMC Directive)**

We, the company GEMÜ Gebr. Müller Apparatebau GmbH & Co. KG  
Fritz-Müller-Strasse 6-8  
74653 Ingelfingen-Criesbach, Germany

hereby declare under our sole responsibility that the below-mentioned product complies with the regulations of the above-mentioned Directive.

**Product:** GEMÜ 1242  
**Product name:** Electrical position indicator  
**The following harmonized standards (or parts thereof) have been applied:** EN IEC 61000-6-4:2007/A1:2011; EN 61000-6-2:2005

**Other applied technical standards / Remarks:**

- 1242 Ordering option Fieldbus A2, A3 and A4: EN 62026-2:2013 + A1:2019

A handwritten signature in blue ink, appearing to read "M. Barghoorn", written over a horizontal line.

M. Barghoorn  
Head of Global Technics

Ingelfingen, 25/11/2022

**23 Declaration of Conformity in accordance with 2014/34/EU (ATEX)**



**Declaration of conformity**  
in accordance with 2014/34/EU (ATEX)

We, **GEMÜ Gebr. Müller Apparatebau GmbH & Co. KG**  
Fritz-Müller-Straße 6-8  
74653 Ingelfingen-Criesbach, Germany

declare that the product listed below complies with the requirements of directive 2014/34/EU for intended use in potentially explosive areas.

**Product:** GEMÜ 1242  
**Product name:** Electrical position indicator  
**Explosion protection designation** Gas: II 3G Ex ec nC IIC T4 Gc X  
Dust: II 3D Ex tc IIIC T80°C Dc X  
**Explanations:** For special conditions or operation limits see chapter "Correct use" in the operating instructions.

The Essential Safety and Health Requirements are met by compliance with the standards listed below that are applicable for the above mentioned product:

- DIN EN 60079-0:2012+A11:2013
- DIN EN 60079-7+A1:2015-12-31
- DIN EN 60079-15:2010-09-30
- DIN EN 60079-31:2014-07-31

The sole responsibility for issuing this declaration of conformity lies with the company GEMÜ Gebr. Müller Apparatebau GmbH & Co. KG.

---

M. Barghoorn  
Head of Global Technics

Ingelfingen, 2nd November 2021





GEMÜ Gebr. Müller Apparatebau GmbH & Co. KG  
Fritz-Müller-Straße 6-8, 74653 Ingelfingen-Criesbach, Germany  
Phone +49 (0) 7940 1230 · info@gemue.de  
www.gemu-group.com

Subject to alteration

03.2024 | 88796460