

GEMÜ 519 eSyLite

Motorized globe valve

EN

Operating instructions

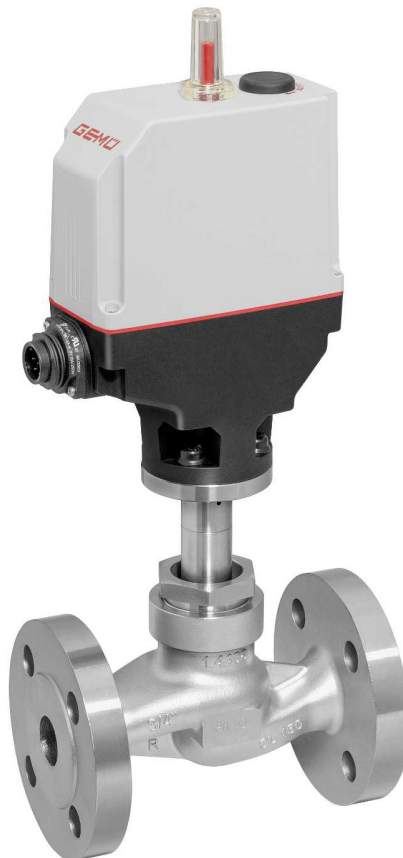

further information
webcode: GW-519



All rights including copyrights or industrial property rights are expressly reserved.

Keep the document for future reference.

© GEMÜ Gebr. Müller Apparatebau GmbH & Co. KG
20.10.2023

Contents

1 General information	4	21 EU Declaration of Conformity In accordance with	
1.1 Information	4	2011/65/EU (RoHS Directive)	29
1.2 Symbols used	4		
1.3 Definition of terms	4		
1.4 Warning notes	4		
2 Safety information	5		
3 Product description	5		
3.1 Construction	5		
3.2 Description	5		
3.3 Function	6		
3.4 Product label	6		
4 GEMÜ CONEXO	6		
5 Correct use	6		
6 Order data	7		
6.1 Order codes	7		
6.2 Order example	8		
7 Technical data	9		
7.1 Medium	9		
7.2 Temperature	9		
7.3 Pressure	9		
7.4 Product conformity	10		
7.5 Mechanical data	11		
7.6 Actuator duty cycle and service life	11		
8 Electrical connection	13		
9 Dimensions	15		
9.1 Installation and actuator dimensions without position indicator	15		
9.2 Installation and actuator dimensions with position indicator	16		
10 Manufacturer's information	20		
10.1 Delivery	20		
10.2 Transport	20		
10.3 Storage	20		
11 Installation in piping	20		
11.1 Preparing for installation	20		
11.2 Installation position	20		
11.3 Installation with flanged connection	21		
12 Operation	21		
12.1 Manual override	21		
13 Troubleshooting	22		
14 Inspection and maintenance	23		
14.1 Spare parts	23		
14.2 Removing the actuator	23		
14.3 Replacing the seals	24		
14.4 Mounting the actuator	24		
15 Removal from piping	25		
16 Disposal	25		
17 Returns	25		
18 EU Declaration of Incorporation according to the EC Machinery Directive 2006/42/EC, Annex II B ...	26		
19 EU Declaration of Conformity in accordance with 2014/68/EU (Pressure Equipment Directive)	27		
20 EU Declaration of Conformity in accordance with 2014/30/EU (EMC Directive)	28		

1 General information

1.1 Information

- The descriptions and instructions apply to the standard versions. For special versions not described in this document the basic information contained herein applies in combination with any additional special documentation.
- Correct installation, operation, maintenance and repair work ensure faultless operation of the product.
- Should there be any doubts or misunderstandings, the German version is the authoritative document.
- Contact us at the address on the last page for staff training information.

1.2 Symbols used

The following symbols are used in this document:

Symbol	Meaning
●	Tasks to be performed
▶	Response(s) to tasks
-	Lists

1.3 Definition of terms

Working medium

The medium that flows through the GEMÜ product.

Control function

The possible actuation functions of the GEMÜ product.

1.4 Warning notes

Wherever possible, warning notes are organised according to the following scheme:

SIGNAL WORD	
Possible symbol for the specific danger	<p>Type and source of the danger</p> <ul style="list-style-type: none"> ▶ Possible consequences of non-observance. ● Measures for avoiding danger.

Warning notes are always marked with a signal word and sometimes also with a symbol for the specific danger.





The following signal words and danger levels are used:

⚠ DANGER	
	<p>Imminent danger!</p> <ul style="list-style-type: none"> ▶ Non-observance can cause death or severe injury.
⚠ WARNING	
	<p>Potentially dangerous situation!</p> <ul style="list-style-type: none"> ▶ Non-observance can cause death or severe injury.

⚠ CAUTION	
	<p>Potentially dangerous situation!</p> <ul style="list-style-type: none"> ▶ Non-observance can cause moderate to light injury.

NOTICE	
	<p>Potentially dangerous situation!</p> <ul style="list-style-type: none"> ▶ Non-observance can cause damage to property.

The following symbols for the specific dangers can be used within a warning note:

Symbol	Meaning
	Danger of explosion!
	Corrosive chemicals!
	Hot plant components!
	Damage to the product!

2 Safety information

The safety information in this document refers only to an individual product. Potentially dangerous conditions can arise in combination with other plant components, which need to be considered on the basis of a risk analysis. The operator is responsible for the production of the risk analysis and for compliance with the resulting precautionary measures and regional safety regulations.

The document contains fundamental safety information that must be observed during commissioning, operation and maintenance. Non-compliance with these instructions may cause:

- Personal hazard due to electrical, mechanical and chemical effects.
- Hazard to nearby equipment.
- Failure of important functions.
- Hazard to the environment due to the leakage of dangerous substances.

The safety information does not take into account:

- Unexpected incidents and events, which may occur during installation, operation and maintenance.
- Local safety regulations which must be adhered to by the operator and by any additional installation personnel.

Prior to commissioning:

1. Transport and store the product correctly.
2. Do not paint the bolts and plastic parts of the product.
3. Carry out installation and commissioning using trained personnel.
4. Provide adequate training for installation and operating personnel.
5. Ensure that the contents of the document have been fully understood by the responsible personnel.
6. Define the areas of responsibility.
7. Observe the safety data sheets.
8. Observe the safety regulations for the media used.

During operation:

9. Keep this document available at the place of use.
10. Observe the safety information.
11. Operate the product in accordance with this document.
12. Operate the product in accordance with the specifications.
13. Maintain the product correctly.
14. Do not carry out any maintenance work and repairs not described in this document without consulting the manufacturer first.

In cases of uncertainty:

15. Consult the nearest GEMÜ sales office.

3 Product description

3.1 Construction

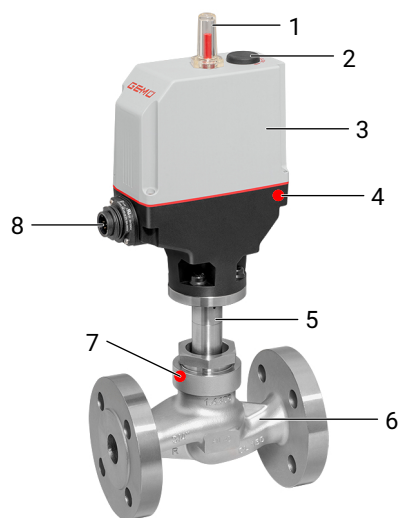

Item	Name	Materials
1	Optical position indicator	PA 12
2	Manual override	
3	Motorized actuator	Reinforced polyamide
4	CONEXO actuator RFID chip	
5	Distance piece with leak detection hole	1.4305 / 1.4408
6	Valve body	1.4408, EN-GJS-400-18-LT (GGG 40.3)
7	CONEXO body RFID chip	
8	Electrical connection	

3.2 Description

The GEMÜ 519 eSyLite is a motorized 2/2-way globe valve. It is available as an Open/Close version. The valve spindle is sealed by a self-adjusting gland packing providing low-maintenance and reliable valve spindle sealing even after a long service life. A wiper ring fitted in front of the gland packing protects the seal against contamination and damage. An integrated optical position indicator is standard. The self-locking actuator holds its position in a stable manner in the event of power supply failure.

3.3 Function

The product controls a flowing medium by being closed or opened by a motorised actuator. The product is designed as an OPEN/CLOSED valve and is not intended for control applications.

The product has an optical position indicator as standard. The optical position indicator indicates the OPEN and CLOSED positions.

3.4 Product label

The product label is located on the actuator. Product label data (example):

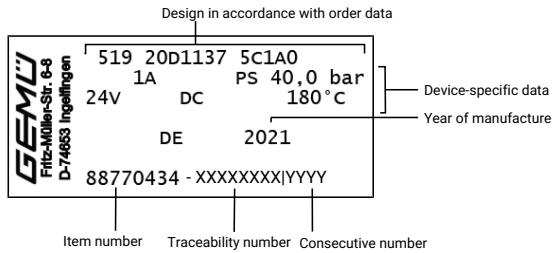

The month of manufacture is encoded in the traceability number and can be obtained from GEMÜ. The product was manufactured in Germany.

The operating pressure stated on the product label applies to a media temperature of 20 °C. The product can be used up to the maximum stated media temperature. You can find the pressure/temperature correlation in the technical data.

4 GEMÜ CONEXO

The interaction of valve components that are equipped with RFID chips and an associated IT infrastructure actively increase process reliability.



Thanks to serialization, every valve and every relevant valve component such as the body, actuator or diaphragm, and even automation components, can be clearly traced and read using the CONEXO pen RFID reader. The CONEXO app, which can be installed on mobile devices, not only facilitates and improves the "installation qualification" process, but also makes the maintenance process much more transparent and easier to document. The app actively guides the maintenance technician through the maintenance schedule and directly provides him with all the information assigned to the valve, such as test reports, testing documentation and maintenance histories. The CONEXO portal acts as a central element, helping to collect, manage and process all data.

For further information on GEMÜ CONEXO please visit:
www.gemu-group.com/conexo

5 Correct use

! DANGER	
	<p>Danger of explosion!</p> <ul style="list-style-type: none"> ▶ Risk of death or severe injury ● Do not use the product in potentially explosive zones.
! WARNING	
<p>Improper use of the product!</p> <ul style="list-style-type: none"> ▶ Risk of severe injury or death ▶ Manufacturer liability and guarantee will be void. ● Only use the product in accordance with the operating conditions specified in the contract documentation and in this document. 	

The product is designed for installation in piping systems and for controlling a working medium.

The product is not intended for use in potentially explosive areas.

1. Use the product in accordance with the technical data.
2. The product is designed as an OPEN/CLOSED valve and is not intended for control applications. Due to the minimum actuation time, sufficiently accurate control is not possible.

6 Order data

The order data provide an overview of standard configurations.

Please check the availability before ordering. Other configurations available on request.

Order codes

1 Type	Code
Globe valve, electrically operated eSyLite	519

2 DN	Code
DN 15	15
DN 20	20
DN 25	25
DN 32	32
DN 40	40
DN 50	50

3 Body configuration	Code
2/2-way body	D

4 Connection type	Code
Flange EN 1092, PN 16, form B, face-to-face dimension FTF EN 558 series 1, ISO 5752, basic series 1	8
Flange EN 1092, PN 25, form B, face-to-face dimension FTF EN 558 series 1, ISO 5752, basic series 1	10
Flange EN 1092, PN 40, form B, face-to-face dimension FTF EN 558 series 1, ISO 5752, basic series 1	11
Flange ANSI Class 125/150 RF, face-to-face dimension FTF EN 558 series 1, ISO 5752, basic series 1, length only for body configuration D	39
Flange JIS 20K, face-to-face dimension FTF EN 558 series 10, ASME/ANSI B16.10 table 1, column 16, DN 50 drilled to JIS 10K	48

5 Valve body material	Code
1.4408, investment casting	37
EN-GJS-400-18-LT (GGG 40.3)	90

6 Seat seal	Code
PTFE	5
PTFE, glass fibre reinforced	5G
1.4404	10

7 Voltage/frequency	Code
24 V DC	C1

8 Control module	Code
ON/OFF actuator (economy)	A0
ON/OFF actuator (economy) emergency power supply module (NC)	A1
ON/OFF actuator (economy) emergency power supply module (NO)	A2
OPEN/CLOSE control with mounted GEMÜ 1215 position indicator	Z0

8 Control module	Code
OPEN/CLOSE control with mounted GEMÜ 1215 position indicator emergency power supply module (NC)	Z1
OPEN/CLOSE control with mounted GEMÜ 1215 position indicator emergency power supply module (NO)	Z2

9 Actuator version	Code
Actuator size 1	1A
Actuator size 3	3A

10 Type of design	Code
Without	
Spindle seal PTFE-PTFE	2013

11 CONEXO	Code
Without	
Integrated RFID chip for electronic identification and traceability	C

Order example

Ordering option	Code	Description
1 Type	519	Globe valve, electrically operated eSyLite
2 DN	20	DN 20
3 Body configuration	D	2/2-way body
4 Connection type	10	Flange EN 1092, PN 25, form B, face-to-face dimension FTF EN 558 series 1, ISO 5752, basic series 1
5 Valve body material	37	1.4408, investment casting
6 Seat seal	5	PTFE
7 Voltage/frequency	C1	24 V DC
8 Control module	A0	ON/OFF actuator (economy)
9 Actuator version	1A	Actuator size 1
10 Type of design		Without
11 CONEXO		Without

7 Technical data

7.1 Medium

Working medium: Corrosive, inert, gaseous and liquid media which have no negative impact on the physical and chemical properties of the body and seal material.

Max. permissible viscosity: 600 mm²/s
Other versions for lower / higher temperatures and higher viscosities on request.

7.2 Temperature

Media temperature: -10 – 180 °C

Ambient temperature: -10 – 60 °C
* depending on version and/or operating parameters (see chapter Duty cycle and service life)
If the emergency power module is used (control module code A1, A2, Z1, Z2), the maximum ambient temperature is reduced to 40 °C.

Storage temperature: -25 – 60 °C

7.3 Pressure

Operating pressure:

DN	Actuator version	
	1A	3A
15	40	-
20	40	-
25	40	-
32	22	40
40	13	25
50	8	17

All pressures are gauge pressures.

For max. operating pressures the pressure / temperature correlation must be observed.

Leakage rate: Leakage rate A to P11/P12 EN 12266-1

Pressure/temperature correlation:

Connection type code ¹⁾	Material code ²⁾	Max. allowable operating pressures in bar at temperature in °C			
		RT	100	150	200
8	37	16.0	16.0	14.5	13.4
10	37	25.0	25.0	22.7	21.0
11	37	40.0	40.0	36.3	33.7
39	37	19.0	16.0	14.8	13.6
8	90	16.0	16.0	15.5	14.7
39	90	17.0	16.0	14.8	13.9

1) **Connection type**

Code 8: Flange EN 1092, PN 16, form B, face-to-face dimension FTF EN 558 series 1, ISO 5752, basic series 1

Code 10: Flange EN 1092, PN 25, form B, face-to-face dimension FTF EN 558 series 1, ISO 5752, basic series 1

Code 11: Flange EN 1092, PN 40, form B, face-to-face dimension FTF EN 558 series 1, ISO 5752, basic series 1

Code 39: Flange ANSI Class 125/150 RF, face-to-face dimension FTF EN 558 series 1, ISO 5752, basic series 1, length only for body configuration D

2) **Valve body material**

Code 37: 1.4408, investment casting

Code 90: EN-GJS-400-18-LT (GGG 40.3)

Kv values:	DN 15:	4.6 m ³ /h
	DN 20:	8.0 m ³ /h
	DN 25:	13.0 m ³ /h
	DN 32:	22.0 m ³ /h
	DN 40:	35.0 m ³ /h
	DN 50:	50.0 m ³ /h

Kv values determined in accordance with DIN EN 60534. The Kv value specifications refer to the largest actuator for the respective nominal size. The Kv values for other product configurations (e.g. other connections or body materials) may differ.

7.4 Product conformity

Machinery Directive: 2006/42/EC

Pressure Equipment Directive: 2014/68/EU

Food: Regulation (EC) No. 1935/2004*
Regulation (EC) No. 10/2011*
FDA*
* depending on version and / or operating parameters

EMC Directive: 2014/30/EU

RoHS Directive: 2011/65/EU

7.5 Mechanical data

Protection class: IP 65 acc. to EN 60529

Actuating speed: Max. 3 mm/s

Installation position: Optional

Weight: **Actuator**

DN	Actuator size	Weight without valve body
15	1A	1.20
20	1A	1.21
25	1A	1.22
32	1A	1.48
32	3A	2.10
40	1A	1.75
40	3A	2.25
50	1A	2.00
50	3A	2.50

Weights in kg

Valve body

DN	Weight
15	2.2
20	3.0
25	3.7
32	5.3
40	6.3
50	8.4

Weights in kg

Mechanical environmental conditions: Class 4M8 acc. to EN 60721-3-4:1998

Vibration: 5g acc. to IEC 60068-2-6 Test Fc

Shock: 25g acc. to 60068-2-27 Test Ea

7.6 Actuator duty cycle and service life

Service life: Class A acc. to EN 15714-2
Minimum 100,000 switching cycles at room temperature and permissible duty cycle.

Duty cycle: max. 30% duty

7.7 Electrical data

Supply voltage: 24 V DC
Tolerance $\pm 10\%$

Operating time: MG 10: 2,5 s
MG 20: 3,5 s
MG 25: 4,0 s
MG 40: 4,5 s
MG 50: 7,0 s

Close tight current / rated current: MG 10: 0,5 A
MG 20: 1,4 A
MG 25: 1,3 A
MG 40: 2,3 A
MG 50: 2,3 A

Starting current / maximum current: MG 10: ca. 2,4 A
MG 20: ca. 2,4 A
MG 25: ca. 2,4 A
MG 40: ca. 4,5 A
MG 50: ca. 4,5 A

Standby current consumption: approx. 10 mA

7.7.1 Digital input signals

Input voltage: max. 30 V DC
≥ 56 kΩ

High level: ≥ 18 V DC

Low level: ≤ 5 V DC

Minimum actuation duration: 600 ms

Input current: < 0.6 mA

7.7.2 Emergency power supply module

Charging current: MG 10, MG 20, MG 25: max. 0,16 A
MG 40: 0,32 A
MG 50: not available

Charging time: approx. 13 min

Service life: Guide value at 25 °C ambient temperature, approx. 3 years

8 Electrical connection

NOTICE

Appropriate cable socket/appropriate mating connector

- The appropriate connector is included for X1.

8.1 Position of the connectors

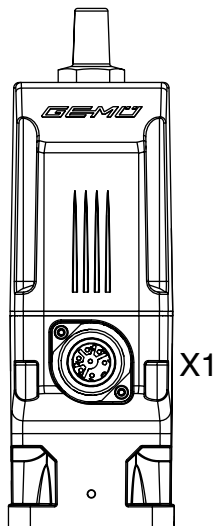

8.2 Electrical connection

Connection X1

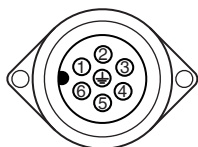

7-pin plug, Binder, type 693

Pin	Signal name
1	24 V supply voltage
2	GND
3	Digital input OPEN
4	Digital input CLOSED
5	n.c.
6	n.c.
7	n.c.

Preferred direction if both digital inputs are present
for device version 00
(see operating instructions – Product label)

Control module ordering option	Preferred direction
A0, Y0, Z0	OPEN
A1, Y1, Z1	CLOSED

Preferred direction if both digital inputs are present for device version 00 (see operating instructions – Product label)	
A2, Y1, Z2	OPEN

Preferred direction if both digital inputs are present for device version 01 (see operating instructions – Product label)	
Control module ordering option	Preferred direction
A0, Y0, Z0	OPEN
A1, Y1, Z1	OPEN
A2, Y2, Z2	CLOSED

8.3 Connection diagram

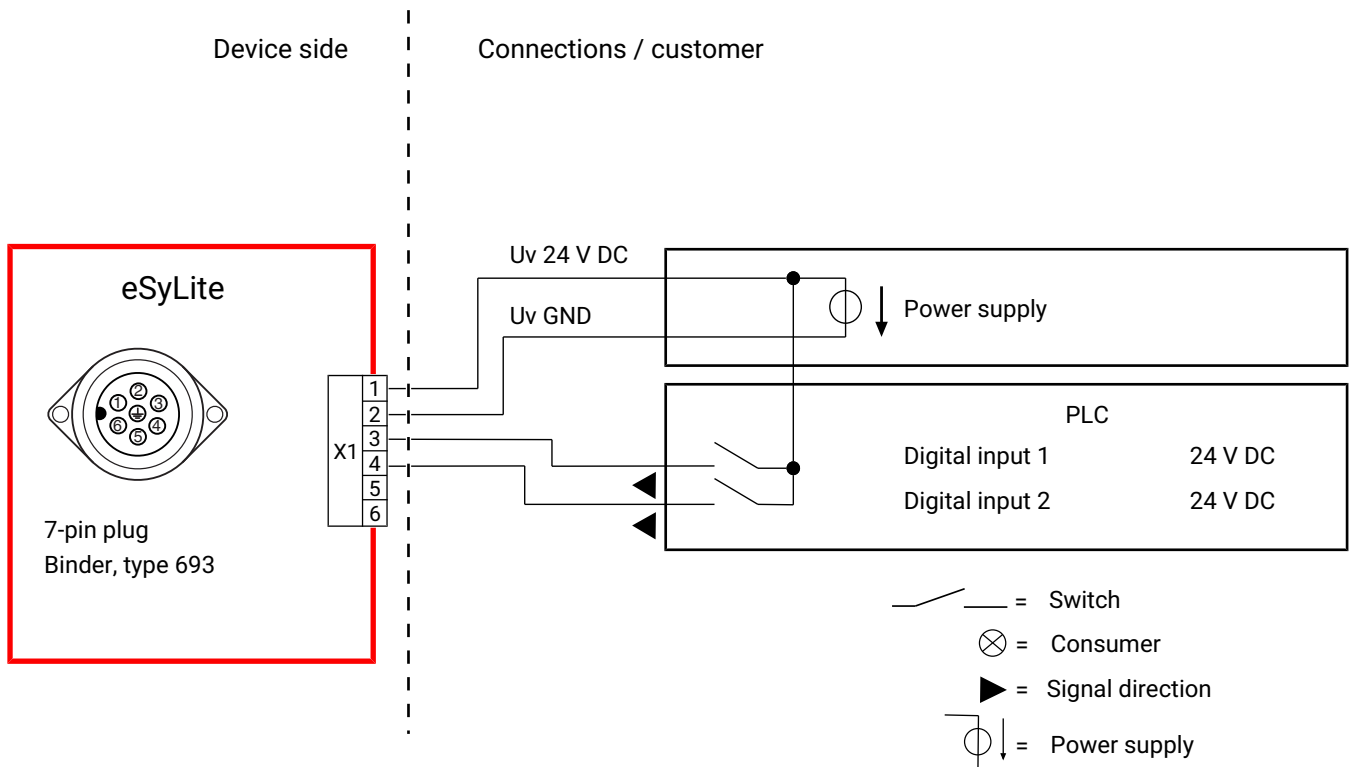

9 Dimensions

9.1 Installation and actuator dimensions without position indicator

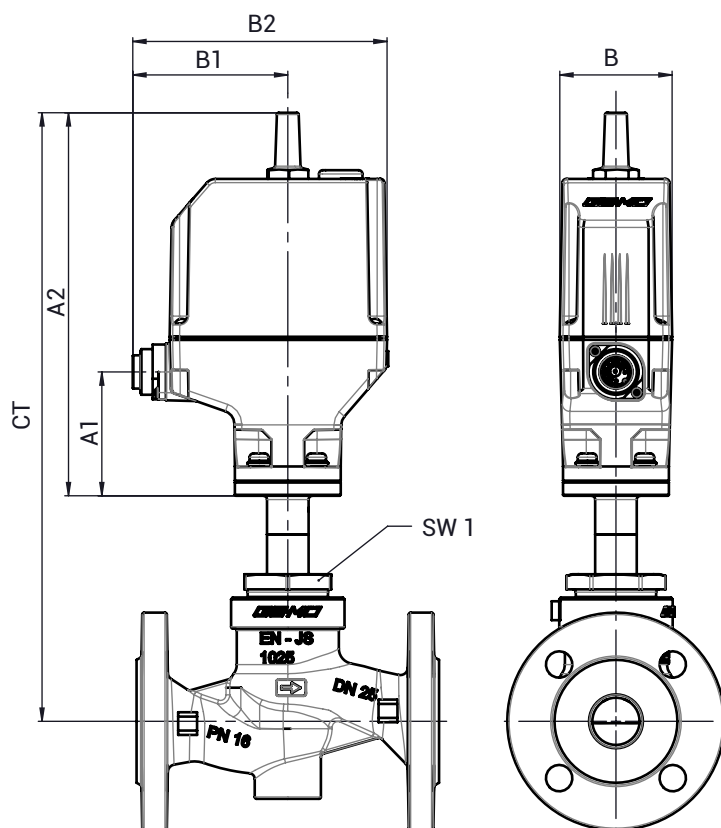

DN	Actuator version	A1	A2	B	B1	B2	CT	SW1
15	1A	65.5	203.0	59.5	82.0	134.5	304.0	36
20	1A	65.5	203.0	59.5	82.0	134.5	311.0	41
25	1A	65.5	203.0	59.5	82.0	134.5	322.0	46
32	1A	65.5	203.0	59.5	82.0	134.5	326.0	55
32	3A	72.0	232.0	80.0	94.5	167.0	356.0	55
40	1A	65.5	203.0	59.5	82.0	134.5	346.0	60
40	3A	72.0	232.0	80.0	94.5	167.0	376.0	60
50	1A	65.5	203.0	59.5	82.0	134.5	352.0	75
50	3A	72.0	232.0	80.0	94.5	167.0	382.0	75

Dimensions in mm

9.2 Installation and actuator dimensions with position indicator

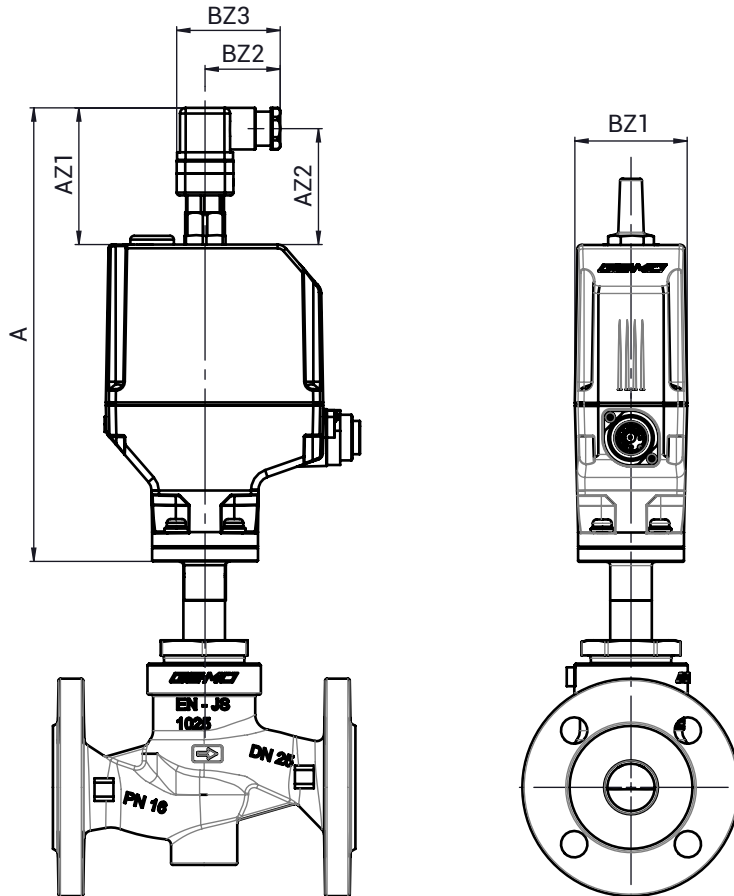

Actuator version	A	AZ1	AZ2	BZ1	BZ2	BZ3
1A	240.0	72.0	61.0	30.0	40.0	55.0
3A	269.0	72.0	61.0	30.0	40.0	55.0

Dimensions in mm

9.3 Body dimensions

9.3.1 Flange EN (code 8)

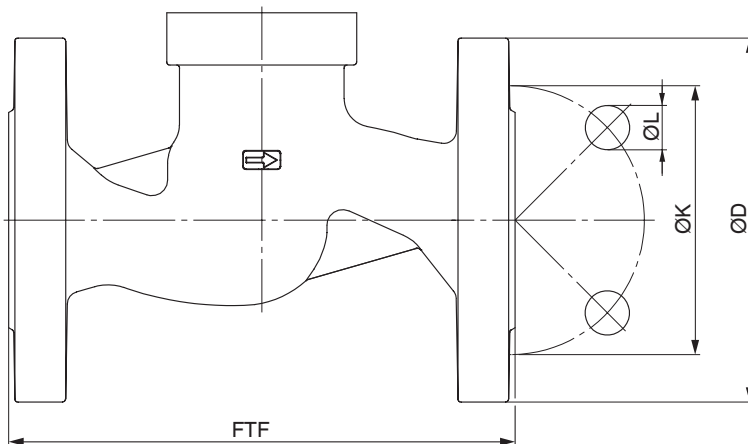

Connection type flange, length EN 558 (code 8)¹⁾, SG iron material (code 90)²⁾

DN	NPS	ø D	FTF	ø K	ø L	n
15	1/2"	95.0	130.0	65.0	14.0	4
20	3/4"	105.0	150.0	75.0	14.0	4
25	1"	115.0	160.0	85.0	14.0	4
32	1¼"	140.0	180.0	100.0	18.0	4
40	1½"	150.0	200.0	110.0	18.0	4
50	2"	165.0	230.0	125.0	18.0	4

Connection type flange, length EN 558 (code 8)¹⁾, investment casting material (code 37)²⁾

DN	NPS	ø D	FTF	ø K	ø L	n
50	2"	165.0	230.0	125.0	18.0	4

Dimensions in mm

n = number of bolts

1) **Connection type**

Code 8: Flange EN 1092, PN 16, form B, face-to-face dimension FTF EN 558 series 1, ISO 5752, basic series 1

2) **Valve body material**

Code 37: 1.4408, investment casting

Code 90: EN-GJS-400-18-LT (GGG 40.3)

9.3.2 Flange EN/JIS (code 10, 11, 48)

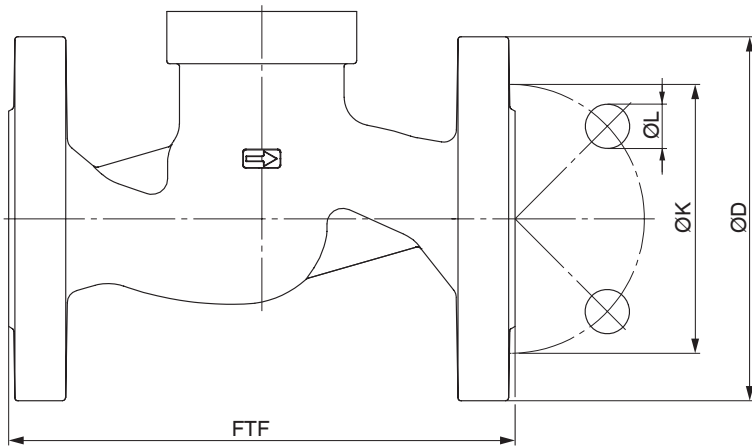

Connection type flange, length EN 558 (code 10)¹⁾, investment casting material (code 37)²⁾

DN	NPS	ø D	FTF	ø k	ø L	n
32	1¼"	140.0	180.0	100.0	18.0	4
40	1½"	150.0	200.0	110.0	18.0	4

Connection type flange, length EN 558 (code 11)¹⁾, investment casting material (code 37)²⁾

DN	NPS	ø D	FTF	ø K	ø L	n
15	1/2"	95.0	130.0	65.0	14.0	4
20	3/4"	105.0	150.0	75.0	14.0	4
25	1"	115.0	160.0	85.0	14.0	4
32	1¼"	140.0	180.0	100.0	18.0	4
40	1½"	150.0	200.0	110.0	18.0	4
50	2"	165.0	230.0	125.0	18.0	4

Connection type flange, length EN 558 (code 48)¹⁾, investment casting material (code 37)²⁾

DN	NPS	ø D	FTF	ø K	ø L	n
15	1/2"	95.0	108.0	70.0	15.0	4
20	3/4"	100.0	117.0	75.0	15.0	4
25	1"	125.0	127.0	90.0	19.0	4
40	1½"	140.0	160.0	105.0	19.0	4
50	2"	155.0	203.0	120.0	19.0	4

Dimensions in mm

n = number of bolts

1) Connection type

Code 10: Flange EN 1092, PN 25, form B, face-to-face dimension FTF EN 558 series 1, ISO 5752, basic series 1

Code 11: Flange EN 1092, PN 40, form B, face-to-face dimension FTF EN 558 series 1, ISO 5752, basic series 1

Code 48: Flange JIS 20K, face-to-face dimension FTF EN 558 series 10, ASME/ANSI B16.10 table 1, column 16, DN 50 drilled to JIS 10K

2) Valve body material

Code 37: 1.4408, investment casting

9.3.3 Flange ANSI Class (code 39)

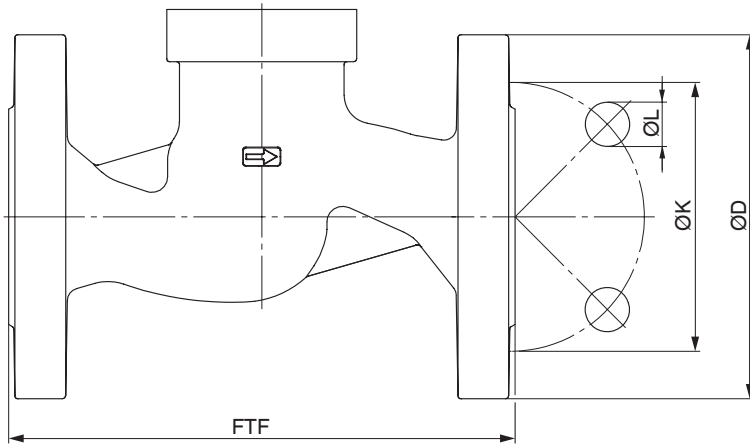

Connection type flange, length EN 558 (code 39)¹⁾, investment casting material (code 37), SG iron material (code 90)²⁾

DN	NPS	Ø D	FTF	Ø K	Ø L	n
15	1/2"	90.0	130.0	60.3	15.9	4
20	3/4"	100.0	150.0	69.9	15.9	4
25	1"	110.0	160.0	79.4	15.9	4
32	1¼"	115.0	180.0	88.9	15.9	4
40	1½"	125.0	200.0	98.4	15.9	4
50	2"	150.0	230.0	120.7	19.0	4

Dimensions in mm

n = number of bolts

1) Connection type

Code 39: Flange ANSI Class 125/150 RF, face-to-face dimension FTF EN 558 series 1, ISO 5752, basic series 1, length only for body configuration D

2) Valve body material

Code 37: 1.4408, investment casting

Code 90: EN-GJS-400-18-LT (GGG 40.3)

10 Manufacturer's information

10.1 Delivery

- Check that all parts are present and check for any damage immediately upon receipt.

The product's performance is tested at the factory. The scope of delivery is apparent from the dispatch documents and the design from the order number.

10.2 Transport

1. Only transport the product by suitable means. Do not drop. Handle carefully.
2. After the installation dispose of transport packaging material according to relevant local or national disposal regulations / environmental protection laws.

10.3 Storage

1. Store the product free from dust and moisture in its original packaging.
2. Avoid UV rays and direct sunlight.
3. Do not exceed the maximum storage temperature (see chapter "Technical data").
4. Do not store solvents, chemicals, acids, fuels or similar fluids in the same room as GEMÜ products and their spare parts.

11 Installation in piping

11.1 Preparing for installation

 **WARNING**

The equipment is subject to pressure!

- ▶ Risk of severe injury or death
- Depressurize the plant.
- Completely drain the plant.

 **WARNING**



Corrosive chemicals!

- ▶ Risk of caustic burns
- Wear appropriate protective gear.
- Completely drain the plant.

 **CAUTION**



Hot plant components!

- ▶ Risk of burns
- Only work on plant that has cooled down.

 **CAUTION**

Exceeding the maximum permissible pressure!

- ▶ Damage to the product
- Provide precautionary measures against exceeding the maximum permitted pressures caused by pressure surges (water hammer).

 **CAUTION**

Use as step!

- ▶ Damage to the product
- ▶ Risk of slipping-off
- Choose the installation location so that the product cannot be used as a foothold.
- Do not use the product as a step or a foothold.

NOTICE

Suitability of the product!

- ▶ The product must be appropriate for the piping system operating conditions (medium, medium concentration, temperature and pressure) and the prevailing ambient conditions.

NOTICE

Tools!

- ▶ The tools required for installation and assembly are not included in the scope of delivery.
- Use appropriate, functional and safe tools.

1. Ensure the product is suitable for the relevant application.
2. Check the technical data of the product and the materials.
3. Keep appropriate tools ready.
4. Wear appropriate protective gear as specified in the plant operator's guidelines.
5. Comply with appropriate regulations for the connections.
6. Installation work must be performed by trained personnel.
7. Shut off the plant or plant component.
8. Secure the plant or plant component against recommissioning.
9. Depressurize the plant or plant component.
10. Completely drain the plant or plant component and allow it to cool down until the temperature is below the media vaporization temperature and cannot cause scalding.
11. Correctly decontaminate, rinse and ventilate the plant or plant component.
12. Lay piping so that the product is protected against transverse and bending forces, and also vibrations and tension.
13. Only install the product between matching aligned pipes (see chapters below).
14. Pay attention to the installation position (see "Installation position" chapter).

11.2 Installation position

The installation position of the product is optional.

11.3 Installation with flanged connection

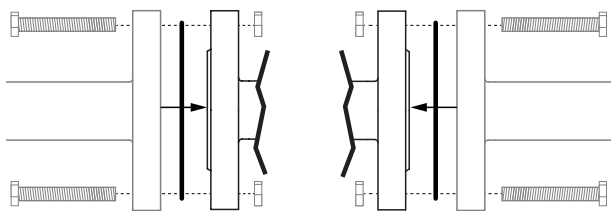

Fig. 1: Flanged connection

NOTICE

Sealing material

- ▶ The sealing material is not included in the scope of delivery.
- Only use appropriate sealing material.

NOTICE

Connector elements

- ▶ The connector elements are not included in the scope of delivery.
- Only use connector elements made of approved materials.
- Observe permissible tightening torque of the bolts.

1. Keep sealing material ready.
2. Carry out preparations for installation (see chapter "Preparing for installation").
3. Ensure clean, undamaged sealing surfaces on the connection flanges.
4. Align flanges carefully before installing them.
5. Clamp the product centrally between the piping with flanges.
6. Centre the gaskets.
7. Connect the valve flange and the piping flange using appropriate sealing materials and matching bolting.
8. Use all flange holes.
9. Tighten the bolts diagonally.

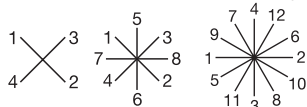

10. Re-attach or reactivate all safety and protective devices.

12 Operation

12.1 Manual override

⚠ WARNING



Damage to the product!

- ▶ Risk of damage to the product
- ▶ Manufacturer liability and guarantee will be void.
- Only operate the manual override **by hand**, because there is no mechanical stop.

NOTICE

- ▶ Manual override may only be used in extreme emergencies as there is a risk of damaging the valve drive. Use of the manual override voids the manufacturer's liability.

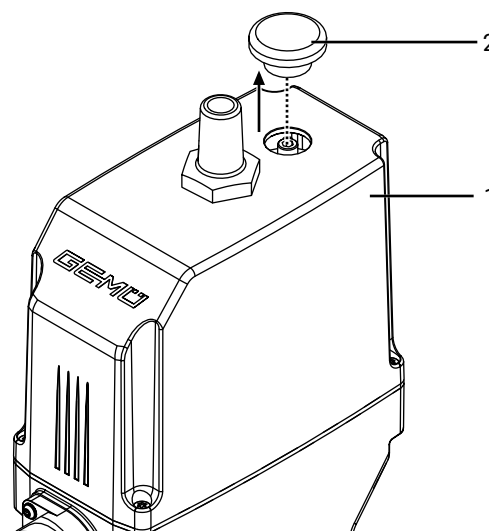

1. Remove the sealing plug 2 from the actuator cover 1 using an appropriate tool.

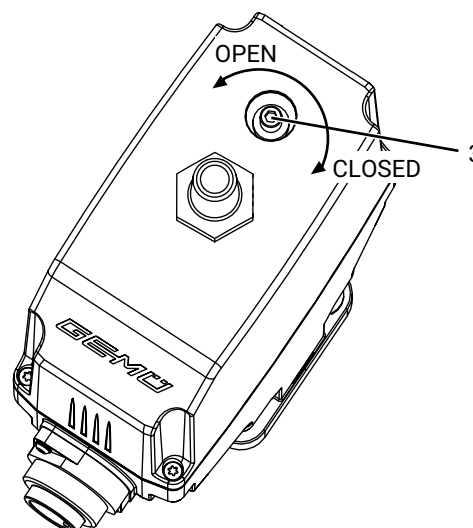

2. Operate the manual override 3 with the hexagon socket (WAF3).
 - ⇒ Turn clockwise to close the valve.
 - ⇒ Turn anticlockwise to open the valve.
3. After actuation, the plug must be reinserted, otherwise the IP protection is no longer guaranteed and the actuator may be damaged.

13 Troubleshooting

Error	Possible cause	Troubleshooting
The product is leaking downstream (does not close or does not close fully)	Operating pressure too high	Operate the product with operating pressure specified in datasheet
	Valve body leaking or damaged	Check valve body for potential damage, replace valve body if necessary
	Foreign matter between seat seal and seat	Remove actuator, remove foreign matter, check seat seal for damage and replace seat seal if necessary
	Seat seal faulty	Check seat seal for damage and replace seat seal if necessary
The product does not open or does not open fully	Actuator defective	Replace the actuator
	Operating pressure too high	Operate the product with operating pressure specified in datasheet
	Foreign matter in the product	Remove and clean the product
	The actuator design is not suitable for the operating conditions	Use an actuator that is designed for the operating conditions
	Voltage is not connected	Connect voltage
	Cable ends incorrectly wired	Wire cable ends correctly
The product does not close or does not close fully	The actuator design is not suitable for the operating conditions	Use an actuator that is designed for the operating conditions
	Foreign matter in the product	Remove and clean the product
	Voltage is not connected	Connect voltage
The product is leaking between actuator and valve body	Bolting between valve body and actuator loose	Tighten bolting between valve body and actuator
	Actuator/valve body damaged	Replace actuator/valve body
	Sealing washer faulty	Check sealing washer and associated sealing surfaces for potential damage and replace parts if necessary
The product is leaking between actuator flange and valve body	Mounting parts loose	Retighten mounting parts
	Valve body / actuator damaged	Replace valve body/actuator
Valve body of the GEMÜ product is leaking	Valve body of the GEMÜ product is faulty or corroded	Check valve body of the GEMÜ product for potential damage, replace valve body if necessary
Body of the GEMÜ product is leaking	Incorrect installation	Check installation of valve body in piping
Valve body connection to piping leaking	Incorrect installation	Check installation of valve body in piping

14 Inspection and maintenance

⚠ WARNING

The equipment is subject to pressure!

- ▶ Risk of severe injury or death
- Depressurize the plant.
- Completely drain the plant.

⚠ CAUTION

Use of incorrect spare parts!

- ▶ Damage to the GEMÜ product
- ▶ Manufacturer liability and guarantee will be void
- Use only genuine parts from GEMÜ.

⚠ CAUTION



Hot plant components!

- ▶ Risk of burns
- Only work on plant that has cooled down.

NOTICE

Exceptional maintenance work!

- ▶ Damage to the GEMÜ product
- Any maintenance work and repairs not described in these operating instructions must not be performed without consulting the manufacturer first.

The operator must carry out regular visual examination of the GEMÜ products dependent on the operating conditions and the potential danger in order to prevent leakage and damage.

The product also must be disassembled and checked for wear in the corresponding intervals.

1. Have servicing and maintenance work performed by trained personnel.
2. Wear appropriate protective gear as specified in plant operator's guidelines.
3. Shut off plant or plant component.
4. Secure the plant or plant component against recommissioning.
5. Depressurize the plant or plant component.
6. Actuate GEMÜ products which are always in the same position four times a year.
7. If necessary, the end position counter **User** can be reset after maintenance or other changes under parameter Cycle Counter.

14.1 Spare parts

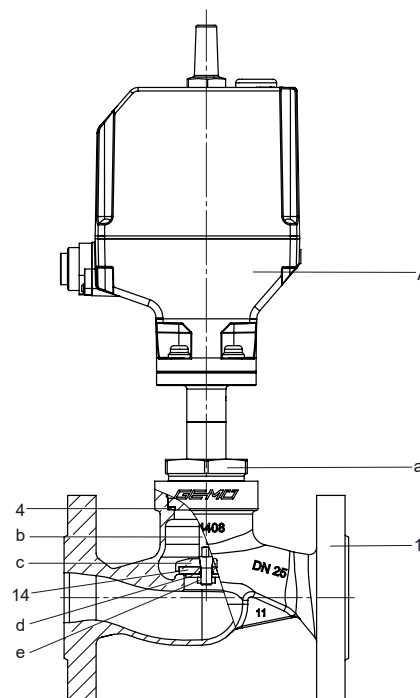

Item	Name	Order designation
A	Actuator	9519...
1	Valve body	K534...
4	Sealing washer	519...SVS...
14	Shut-off seal	519...SVS...

14.2 Removing the actuator

1. Move the actuator **A** to the open position.
2. Actuator sizes 1A and 3A: Undo union nut **a**.
3. Remove actuator **A** from valve body **1**.
4. Clean all parts of contamination (do not damage parts during cleaning).
5. Check parts for potential damage, replace if necessary (only use genuine parts from GEMÜ).

14.3 Replacing the seals

NOTICE

Sealing washer!

- Replace sealing washer **4** each time the actuator is disassembled/assembled.

1. Remove actuator **A** (see chapter "Removing the actuator").
2. Remove sealing washer **4** from the valve body.
3. Loosen nut **e** on spindle **b** (hold spindle **b** with appropriate tool that will not damage the spindle surfaces).
4. Remove seat seal **14**.
5. Clean all parts; do not scratch or damage the parts during cleaning.
6. Insert new seat seal **14**.
7. Apply appropriate thread locking compound on the thread of spindle **b**.
8. Fix spindle **b** in place with nut **e** (hold spindle **b** in place with appropriate tools which do not damage the spindle surfaces).
9. Insert new sealing washer **4** in valve body **1**.
10. Mount actuator **A** (see chapter "Mounting the actuator").

14.4 Mounting the actuator

1. Move the actuator **A** to the open position.
2. Lubricate the thread of union nut **a** using a suitable lubricant.
3. Place actuator **A** on valve body **1** approx. 90° in front of the end position (orientation of the connections) and screw hand tight with union nut **a**.
4. Tighten union nut **a** with an open-end wrench (for torques, see table).
 - ⇒ This rotates the actuator clockwise approx. 90° to the desired position.

Actuator sizes 1A and 3A

Nominal size	Torque
DN 10	90 Nm
DN 15	90 Nm
DN 20	100 Nm
DN 25	120 Nm
DN 32	120 Nm
DN 40	150 Nm
DN 50	200 Nm

5. Move the actuator **A** to the closed position.
6. With the valve fully assembled, check the function and tightness.

15 Removal from piping

1. Remove in reverse order to installation.
2. Unscrew the electrical wiring.
3. Disassemble the product. Observe warning notes and safety information.

16 Disposal

1. Pay attention to adhered residual material and gas diffusion from penetrated media.
2. Dispose of all parts in accordance with the disposal regulations/environmental protection laws.

17 Returns

Legal regulations for the protection of the environment and personnel require that the completed and signed return delivery note is included with the dispatch documents. Returned goods can be processed only when this note is completed. If no return delivery note is included with the product, GEMÜ cannot process credits or repair work but will dispose of the goods at the operator's expense.

1. Clean the product.
2. Request a return delivery note from GEMÜ.
3. Complete the return delivery note.
4. Send the product with a completed return delivery note to GEMÜ.

18 EU Declaration of Incorporation according to the EC Machinery Directive 2006/42/EC, Annex II B



EU Declaration of Incorporation

according to the EC Machinery Directive 2006/42/EC, Annex II B

We, the company **GEMÜ Gebr. Müller Apparatebau GmbH & Co. KG**
Fritz-Müller-Strasse 6-8
74653 Ingelfingen-Criesbach, Germany

hereby declare under our sole responsibility that the below-mentioned product complies with the relevant essential health and safety requirements in accordance with Annex I of the above-mentioned Directive.

Product: GEMÜ 519
Product name: Motorized globe valve
The following essential health and safety requirements of the EC Machinery Directive 2006/42/EC, Annex I have been applied or adhered to: 1.1.2.; 1.1.3.; 1.1.5.; 1.3.2.; 1.3.4.; 1.3.7.; 1.3.8.; 1.5.1.; 1.5.13.; 1.5.2.; 1.5.4.; 1.5.6.; 1.5.7.; 1.5.8.; 1.6.1.; 1.6.3.; 1.6.5.; 1.7.1.; 1.7.1.1.; 1.7.2.; 1.7.3.; 1.7.4.; 1.7.4.1.; 1.7.4.2.; 1.7.4.3.
The following harmonized standards (or parts thereof) have been applied: EN ISO 12100:2010

We also declare that the specific technical documents have been created in accordance with part B of Annex VII.

The manufacturer undertakes to transmit relevant technical documents on the partly completed machinery to the national authorities in response to a reasoned request. This communication takes place electronically.

This does not affect the industrial property rights.

The partly completed machinery may be commissioned only if it has been determined, if necessary, that the machinery into which the partly completed machinery is to be installed meets the provisions of the Machinery Directive 2006/42/EC.

M. Barghoorn
Head of Global Technics

Ingelfingen, 17/07/2023

19 EU Declaration of Conformity in accordance with 2014/68/EU (Pressure Equipment Directive)



EU Declaration of Conformity

in accordance with 2014/68/EU (Pressure Equipment Directive)

We, the company GEMÜ Gebr. Müller Apparatebau GmbH & Co. KG
Fritz-Müller-Strasse 6-8
74653 Ingelfingen-Criesbach, Germany

hereby declare under our sole responsibility that the below-mentioned product complies with the regulations of the above-mentioned Directive.

Product: GEMÜ 519
Product name: Motorized globe valve
Notified body: TÜV Rheinland Industrie Service GmbH
Am Grauen Stein 1
51105 Cologne, Germany

ID number of the notified body: 0035
No. of the QA certificate: 01 202 926/Q-02 0036

Applied conformity assessment procedure(s): Module H

The following harmonized standards (or parts thereof) have been applied: EN 12516-3:2002/AC:2003

Information for products with a nominal size \leq DN 25:

The products are developed and produced according to GEMÜ's in-house process instructions and standards of quality which comply with the requirements of ISO 9001 and ISO 14001. According to Article 4, Paragraph 3 of the Pressure Equipment Directive 2014/68/EU, these products must not be identified by a CE-marking.

Other applied technical standards / Remarks:

- AD 2000

M. Barghoorn
Head of Global Technics

Ingelfingen, 17/07/2023

GEMÜ Gebr. Müller Apparatebau GmbH & Co. KG
Fritz-Müller-Straße 6-8 D-74653 Ingelfingen-Criesbach

www.gemu-group.com
info@gemu.de

20 EU Declaration of Conformity in accordance with 2014/30/EU (EMC Directive)



EU Declaration of Conformity
in accordance with 2014/30/EU (EMC Directive)

We, the company GEMÜ Gebr. Müller Apparatebau GmbH & Co. KG
Fritz-Müller-Strasse 6-8
74653 Ingelfingen-Criesbach, Germany

hereby declare under our sole responsibility that the below-mentioned product complies with the regulations of the above-mentioned Directive.

Product: GEMÜ 519
Product name: Motorized globe valve

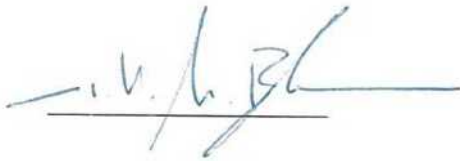

M. Barghoorn
Head of Global Technics
Ingelfingen, 17/07/2023

21 EU Declaration of Conformity In accordance with 2011/65/EU (RoHS Directive)



EU Declaration of Conformity
In accordance with 2011/65/EU (RoHS Directive)

We, the company GEMÜ Gebr. Müller Apparatebau GmbH & Co. KG
Fritz-Müller-Strasse 6-8
74653 Ingelfingen-Criesbach, Germany

hereby declare under our sole responsibility that the below-mentioned product complies with the regulations of the above-mentioned Directive.

Product: GEMÜ 519
Product name: Motorized globe valve
The following harmonized standards (or parts thereof) have been applied: EN IEC 63000:2018

A handwritten signature in blue ink, appearing to read 'M. Barghoorn', is written over a horizontal line.

M. Barghoorn
Head of Global Technics
Ingelfingen, 17/07/2023



GEMÜ Gebr. Müller Apparatebau GmbH & Co. KG
Fritz-Müller-Straße 6-8, 74653 Ingelfingen-Criesbach, Germany
Phone +49 (0) 7940 1230 · info@gemue.de
www.gemu-group.com

Subject to alteration

10.2023 | 88792748