

GEMÜ 52

Electrically operated solenoid valve

EN **Operating instructions**



All rights including copyrights or industrial property rights are expressly reserved.

Keep the document for future reference.

© GEMÜ Gebr. Müller Apparatebau GmbH & Co. KG
06.05.2024

Contents

1	General information	4
1.1	Information	4
1.2	Symbols used	4
1.3	Definition of terms	4
1.4	Warning notes	4
2	Safety information	5
3	Product description	5
3.1	Construction	5
3.2	Description	5
3.3	Function	6
3.4	Product label	6
4	Correct use	7
5	Order data	8
6	Technical data	9
7	Dimensions	11
8	Manufacturer's information	12
8.1	Delivery	12
8.2	Transport	12
8.3	Storage	12
8.4	Scope of delivery	12
9	Installation in piping	12
9.1	Installation with solvent cement sockets	12
9.2	Installation with threaded sockets	12
10	Electrical connection	13
11	Commissioning	13
12	Operation	14
13	Inspection and maintenance	14
13.1	Cleaning the product	14
13.2	Spare parts	15
14	Troubleshooting	16
15	Removal from piping	17
16	Disposal	17
17	Returns	17

1 General information

1.1 Information

- The descriptions and instructions apply to the standard versions. For special versions not described in this document the basic information contained herein applies in combination with any additional special documentation.
- Correct installation, operation, maintenance and repair work ensure faultless operation of the product.
- Should there be any doubts or misunderstandings, the German version is the authoritative document.
- Contact us at the address on the last page for staff training information.

1.2 Symbols used

The following symbols are used in this document:

Symbol	Meaning
●	Tasks to be performed
▶	Response(s) to tasks
–	Lists

1.3 Definition of terms

Working medium

The medium that flows through the GEMÜ product.

1.4 Warning notes



Wherever possible, warning notes are organised according to the following scheme:



SIGNAL WORD	
Possible symbol for the specific danger	Type and source of the danger ▶ Possible consequences of non-observance. ● Measures for avoiding danger.

Warning notes are always marked with a signal word and sometimes also with a symbol for the specific danger.

The following signal words and danger levels are used:



 DANGER	
	Imminent danger! ▶ Non-observance can cause death or severe injury.

 WARNING	
	Potentially dangerous situation! ▶ Non-observance can cause death or severe injury.

 CAUTION	
	Potentially dangerous situation! ▶ Non-observance can cause moderate to light injury.

NOTICE	
	Potentially dangerous situation! ▶ Non-observance can cause damage to property.

The following symbols for the specific dangers can be used within a warning note:

Symbol	Meaning
	Danger of explosion!
	Hot plant components!
	Risk of electric shock

2 Safety information

The safety information in this document refers only to an individual product. Potentially dangerous conditions can arise in combination with other plant components, which need to be considered on the basis of a risk analysis. The operator is responsible for the production of the risk analysis and for compliance with the resulting precautionary measures and regional safety regulations.

The document contains fundamental safety information that must be observed during commissioning, operation and maintenance. Non-compliance with these instructions may cause:

- Personal hazard due to electrical, mechanical and chemical effects.
- Hazard to nearby equipment.
- Failure of important functions.
- Hazard to the environment due to the leakage of dangerous substances.

The safety information does not take into account:

- Unexpected incidents and events, which may occur during installation, operation and maintenance.
- Local safety regulations which must be adhered to by the operator and by any additional installation personnel.

Prior to commissioning:

1. Transport and store the product correctly.
2. Do not paint the bolts and plastic parts of the product.
3. Carry out installation and commissioning using trained personnel.
4. Provide adequate training for installation and operating personnel.
5. Ensure that the contents of the document have been fully understood by the responsible personnel.
6. Define the areas of responsibility.
7. Observe the safety data sheets.
8. Observe the safety regulations for the media used.

During operation:

9. Keep this document available at the place of use.
10. Observe the safety information.
11. Operate the product in accordance with this document.
12. Operate the product in accordance with the specifications.
13. Maintain the product correctly.
14. Do not carry out any maintenance work and repairs not described in this document without consulting the manufacturer first.

In cases of uncertainty:

15. Consult the nearest GEMÜ sales office.

3 Product description

3.1 Construction

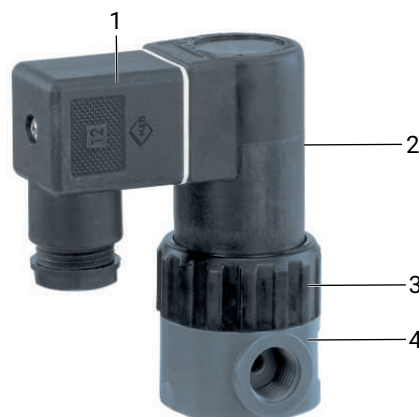

Item	Name	Materials
1	Plug	PA
2	Coil housing	PP
3	Union of valve housing	PVC-U, grey or PVDF
4	Valve body	PVC-U, grey or PVDF
	Seal materials	FPM, PTFE or EPDM

3.2 Description

The GEMÜ 52 directly controlled 2/2-way solenoid valve has a completely plastic encapsulated coil. The armature is sealed by a bellows made of PTFE backed by an additional safety diaphragm. The valve body is available in various materials and with a straight through or angle valve body design.

3.3 Function

The GEMÜ 52 directly controlled 2/2-way plastic solenoid valve is designed for controlling media.

When the valve is closed the medium flows into the valve body and presses onto the piston. The valve remains closed. Observe the permissible operating pressure (see "Technical data", page 9).

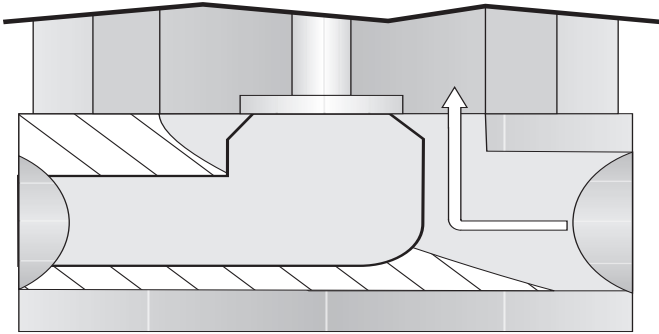

Fig. 1: Valve CLOSED

⚠ CAUTION
<p>Operating pressure too high</p> <p>► Damage to the solenoid / destruction of the solenoid.</p>
NOTICE
<p>Operating pressure too high</p> <p>► The valve cannot be opened electromagnetically if the operating pressure is too high.</p>

When voltage is applied the solenoid in the valve actuator is activated and lifts the armature. This opens the valve outlet.

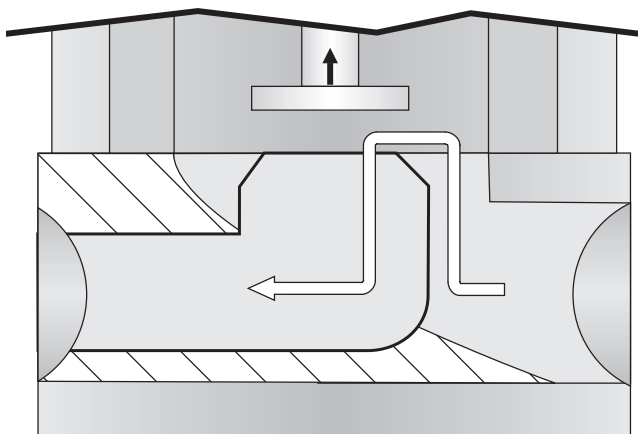
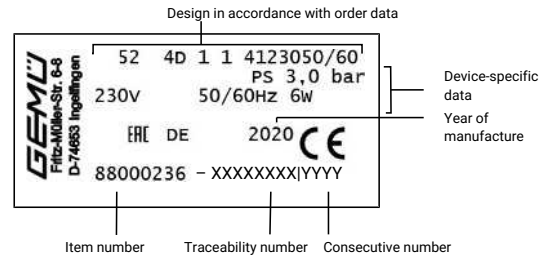

Fig. 2: Valve OPEN

3.4 Product label

The product label is located on the actuator. Product label data (example):



The month of manufacture is encoded in the traceability number and can be obtained from GEMÜ. The product was manufactured in Germany.

The operating pressure stated on the product label applies to a media temperature of 20 °C. The product can be used up to the maximum stated media temperature. You can find the pressure/temperature correlation in the technical data.

4 Correct use

DANGER



Danger of explosion!

- ▶ Risk of severe injury or death
- Only versions that have been approved according to their technical data may be used in potentially explosive environments.

WARNING

Improper use of the product!

- ▶ Risk of severe injury or death
- ▶ Manufacturer liability and guarantee will be void.
- Only use the product in accordance with the operating conditions specified in the contract documentation and in this document.

The product is designed for installation in piping systems and for controlling a working medium.

1. Use the product in accordance with the technical data.
2. Protect the product from direct weathering.

5 Order data

The order data provide an overview of standard configurations.

Please check the availability before ordering. Other configurations available on request.

Order codes

1 Type	Code
Solenoid valve, directly controlled	52

2 DN	Code
DN 2	2
DN 4	4
DN 6	6

3 Body configuration	Code
2/2-way body	D

4 Connection type	Code
Threaded socket DIN ISO 228	1

5 Valve body material	Code
PVC-U, grey	1
PVDF	20

6 Seal material	Code
FKM	4
PTFE	5

6 Seal material	Code
EPDM	14

7 Control function	Code
Normally closed (NC)	1

8 Voltage	Code
24 V	24
120 V	120
230 V	230

9 Frequency	Code
DC	DC
50 - 60 Hz	50/60

10 Special specification	Code
UL approval	U
Without	

11 CONEXO	Code
Integrated RFID chip for electronic identification and traceability	C

Order example

Ordering option	Code	Description
1 Type	52	Solenoid valve, directly controlled
2 DN	4	DN 4
3 Body configuration	D	2/2-way body
4 Connection type	1	Threaded socket DIN ISO 228
5 Valve body material	1	PVC-U, grey
6 Seal material	4	FKM
7 Control function	1	Normally closed (NC)
8 Voltage	230	230 V
9 Frequency	50/60	50 - 60 Hz
10 Special specification		Without
11 CONEXO	C	Integrated RFID chip for electronic identification and traceability

6 Technical data

6.1 Medium

Working medium: Corrosive, inert, gaseous and liquid media which have no negative impact on the physical and chemical properties of the body and seal material.

6.2 Temperature

Media temperature: PVC-U, grey (code 1): 10 to 60 °C
PVDF (code 20): -20 to 100 °C

Ambient temperature: 10 – 40 °C

Storage temperature: 0 – 40 °C

6.3 Pressure

Operating pressure: DN 2: 0 to 6.0 bar
DN 4: 0 to 3.0 bar
DN 6: 0 to 1.5 bar
0 – 6 bar
All pressures are gauge pressures. Operating pressure values were determined with static operating pressure applied on one side of a closed valve. Sealing at the valve seat and atmospheric sealing is ensured for the given values.
Information on operating pressures applied on both sides and for high purity media on request.

Kv values: DN 2: 0.15 m³/h
DN 4: 0.30 m³/h
DN 6: 0.60 m³/h

Leakage rate:	Seat seal	Standard	Test procedure	Leakage rate	Test medium
	EPDM, FKM, PTFE	DIN EN 12266-1	P12	A	Air

6.4 Product compliance

Machinery Directive: 2006/42/EC
Technical standards used:
DIN EN ISO 12100
Safety of machinery – General principles for design
-Risk assessment and risk reduction ISO 12100:2010)
-German version EN ISO 12100:2010

Pressure Equipment Directive: 2014/68/EU

Low Voltage Directive: 2014/35/EU
Technical standards used:
EN 61010-1:2010/A1:2019/AC:2019-04
EN IEC 61010-2-201:2018

Approvals: UL approval, UR (recognized) Y10Z2
Only for 24 V 50/60 Hz, 230 V 50/60 Hz and 24 V DC

6.5 Mechanical data

Protection class:	IP 65
Weight:	212 g
Cable gland:	PG 11

6.6 Electrical data

Power consumption:	Pull in / Hold in AC and DC voltage: 6.0 W / 7.45 W (with UL approval)
Permissible voltage tolerance:	±10 % to VDE 0580
Duty cycle:	Continuous duty
Wiring note:	Special wiring on request. When using electronic switches and additional wiring, carefully design out any potential residual currents upon installation.
Installation note:	Please note: A plug with an integrated bridge rectifier must be used for the AC design (provided in the scope of delivery).

7 Dimensions

7.1 Actuator dimensions

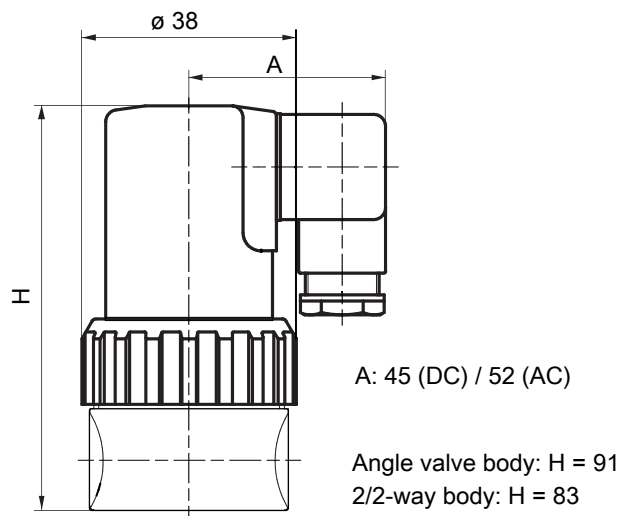

Dimensions in mm

7.2 Body dimensions

7.2.1 Threaded socket (code 1)

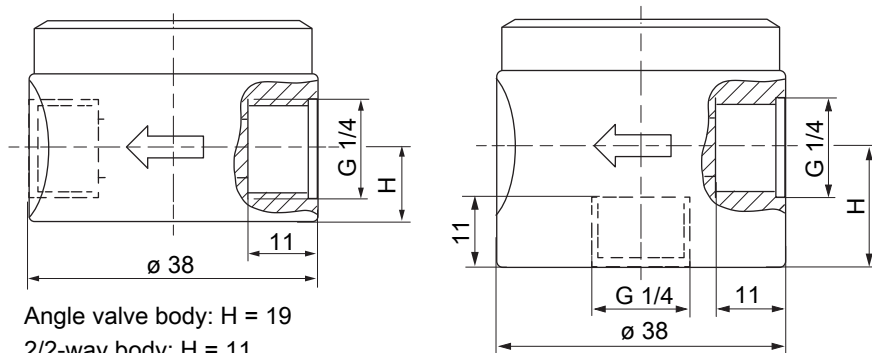

Dimensions in mm

7.3 Mounting dimensions

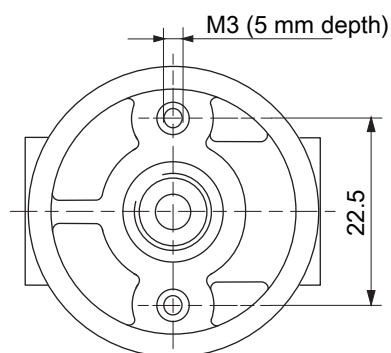

Dimensions in mm

8 Manufacturer's information

8.1 Delivery

- Check that all parts are present and check for any damage immediately upon receipt.

The product's performance is tested at the factory. The scope of delivery is apparent from the dispatch documents and the design from the order number.

8.2 Transport

1. Only transport the product by suitable means. Do not drop. Handle carefully.
2. After the installation dispose of transport packaging material according to relevant local or national disposal regulations / environmental protection laws.

8.3 Storage

1. Store the product free from dust and moisture in its original packaging.
2. Avoid UV rays and direct sunlight.
3. Do not exceed the maximum storage temperature (see chapter "Technical data").
4. Do not store solvents, chemicals, acids, fuels or similar fluids in the same room as GEMÜ products and their spare parts.

8.4 Scope of delivery

The following is included in the scope of delivery:

- Solenoid valve with solenoid coil
- Plug
- Installation, operating and maintenance instructions

9 Installation in piping

WARNING

The equipment is subject to pressure!

- ▶ Risk of severe injury or death
- Depressurize the plant or plant component.
- Completely drain the plant or plant component.

CAUTION



Hot plant components!

- ▶ Risk of burns
- Only work on plant that has cooled down.

CAUTION

Operating pressure too high or working medium temperature too high

- ▶ Damage to the valve body
- Only install the solenoid valve in aligned pipes in order to avoid stresses in the valve body.
- Do not exceed the permissible operating pressure.
- Do not exceed the permissible temperature of the working medium.

CAUTION

Danger from flow contrary to flow direction!

- ▶ Damage to the solenoid valve.
- Only operate the solenoid valve in flow direction.
- Take precautionary measures in case of expected reverse flow (e.g. check valve).

9.1 Installation with solvent cement sockets

CAUTION

Wrong solvent cement

- ▶ Valve body will be damaged.
- Only use solvent cement suitable for the valve body.

NOTICE

- ▶ The solvent cement is not included in the scope of delivery.
- Only use suitable solvent cement!

1. Apply solvent cement inside the valve body socket connections and on the piping as specified by the solvent cement manufacturer.
2. Solvent cement the valve body to the piping.

9.2 Installation with threaded sockets

NOTICE

Thread sealant!

- ▶ The thread sealant is not included in the scope of delivery.
- Only use appropriate thread sealant.

- Screw the threaded connections into the piping in accordance with valid standards.

10 Electrical connection

⚠ DANGER



Risk of electric shock

- ▶ Risk of injury or death (if operating voltage is higher than safe extra low voltage).
- ▶ Electric shock can cause severe burns and fatal injury.
- Work on electrical connections only by qualified trained personnel.
- Disconnect the cable from the power supply before making the electrical connection.
- Connect the protective earth conductor.

⚠ CAUTION

AC voltage

- ▶ Solenoid valve will be destroyed by wrong plug.
- Solenoid valves used with AC voltage may only be operated with a plug with a built-in rectifier.

NOTICE

- ▶ Suitable wire end ferrules must be used when connecting the supply line in the plug!

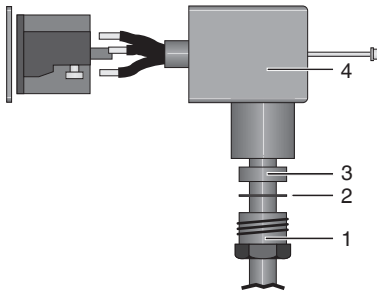

1. Insert the cable through the locking screw **1**, the pressure ring **2**, the seal **3** and the housing of the plug **4**.

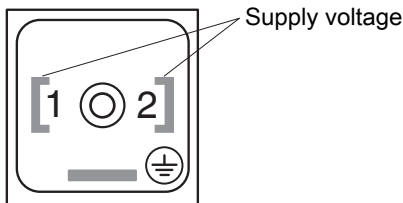

Item	Name
1	Supply voltage
2	Supply voltage

Item	Name
	Protective earth conductor (PE)

2. Connect the cable to the relevant terminals on the terminal block.
3. Push the terminal block into the housing of the plug (acc. to DIN EN 175301-803, previously DIN 43650) until it audibly clicks in position.
4. Ensure that the cable is not caught.
5. Tighten the locking screw on the plug.

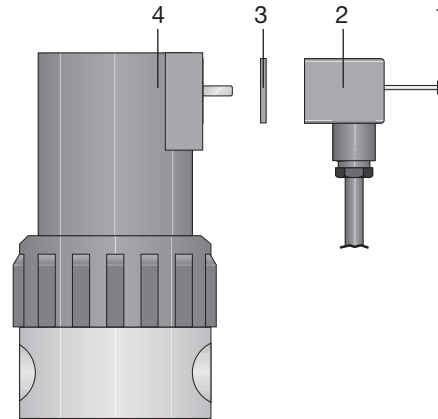

6. Push the plug **2** and the gasket **3** onto the valve actuator **4**.
7. Tighten the fixing screw **1** with a torque of approx. 0.6 Nm.

NOTICE

- ▶ If the torque is too high the thread may be stripped.

11 Commissioning

⚠ CAUTION

Medium flowing out

- ▶ Danger from medium flowing out.
- Before commissioning make sure that there is no danger from medium flowing out.
- Before commissioning check the tightness of the media connections.

NOTICE

Operating pressure too high

- ▶ The valve cannot be opened electromagnetically if the operating pressure is too high.

⚠ CAUTION

Foreign matter

- ▶ Damage to the valves.
- If the plant is new and after repairs, rinse the piping system with the valves fully open.
- ⇒ The plant operator is responsible for selecting the cleaning material and performing the procedure.

1. Make sure that the operating voltage corresponds with the permissible valve voltage.
2. Make sure that the unit is installed properly.
3. Check the function of the solenoid valve.
4. Check the tightness of the media connections and the solenoid valve itself.

12 Operation

During normal operation there is no need for adjustments at the valve.

13 Inspection and maintenance

⚠ WARNING

The equipment is subject to pressure!

- ▶ Risk of severe injury or death
- Depressurize the plant or plant component.
- Completely drain the plant or plant component.

⚠ CAUTION

Use of incorrect spare parts!

- ▶ Damage to the GEMÜ product
- ▶ Manufacturer liability and guarantee will be void.
- Use only genuine parts from GEMÜ.

⚠ CAUTION



Hot plant components!

- ▶ Risk of burns
- Only work on plant that has cooled down.

NOTICE

Exceptional maintenance work!

- ▶ Damage to the GEMÜ product
- Any maintenance work and repairs not described in these operating instructions must not be performed without consulting the manufacturer first.

The operator must carry out regular visual examination of the GEMÜ products dependent on the operating conditions and the potential danger in order to prevent leakage and damage.

The product also must be disassembled and checked for wear in the corresponding intervals.

1. Have servicing and maintenance work performed by trained personnel.
2. Wear appropriate protective gear as specified in plant operator's guidelines.
3. Shut off plant or plant component.
4. Secure the plant or plant component against recommissioning.
5. Depressurize the plant or plant component.
6. Actuate GEMÜ products which are always in the same position four times a year.

13.1 Cleaning the product

⚠ CAUTION

Foreign matter

- ▶ Damage to the valves.
- If the plant is new and after repairs, rinse the piping system with the valves fully open.
- ⇒ The plant operator is responsible for selecting the cleaning material and performing the procedure.

- Clean the product with a damp cloth.
- Do **not** clean the product with a high pressure cleaning device.

13.2 Spare parts

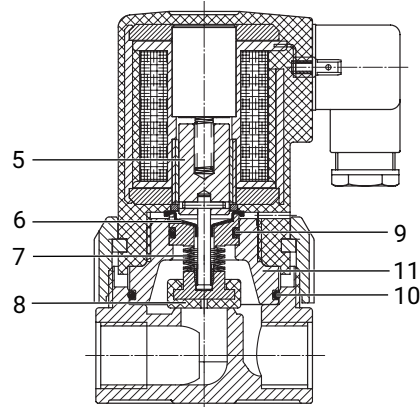

Item	Name	Product version	Item no.	Order designation
1	Plug	AC voltages (with rectifier)	88668464	2026000Z AM160BV2 2L4
		DC voltages (without rectifier)	88668465	2026000Z AM160002 2L4
2	Coil housing	230 V AC, PVC	88015064	52000S01 1 23050/60
		230 V AC, PVDF	88015064	52000S01 1 23050/60
		24 V DC, PVC	88058689	52000S01 1 24 DC
		24 V DC, PVDF	88903859	52000S0120 24 DC
		120 V AC, PVC	88903852	52000S01 1 11050/60
		120 V AC, PVDF	88903853	52000S0120 11050/60
3	Union nut, clamping ring	PVC	88015071	52000SUM 1
		PVDF	88015072	52000SUM20
4	Valve body	DN 2, threaded socket, PVC	88015244	K 52 2D 1 1
		DN 4, threaded socket, PVC	88018593	K 52 4D 1 1
		DN 6, threaded socket, PVC	88018600	K 52 6D 1 1
		DN 2, threaded socket, PVDF	88015248	K 52 2D 120
		DN 4, threaded socket, PVDF	88018595	K 52 4D 120
		DN 6, threaded socket, PVDF	88018602	K 52 6D 120
5		Armature	-	-
6		Isolating diaphragm	-	-
7		Bellows	-	-
8		Seat shut-off seal	-	-
9		O-ring	-	-
10		O-ring	-	-
11	Distance piece	PVC or PVDF	-	-
	Complete armature assembly kit (comprising items 5 to 10)	PVC, EPDM	88015065	52000SAN 14
		PVC, FKM	88015066	52000SAN 4
		PVC, PTFE (shut-off seal made of PTFE, O-rings made of FKM)	88015067	52000SAN 1 5
		PVDF, EPDM	88042889	52000SAN2014
		FKM	88015066	52000SAN 4
		PVDF, PTFE (shut-off seal made of PTFE, O-rings made of FKM)	88398886	52000SAN 5
	Wearing parts kit (comprising items 8, 9, 10)	EPDM	88015074	52000S05 14
		PTFE (shut-off seal made of PTFE, O-rings made of FKM)	88015075	52000S05 5
		FKM	88015076	52000S05 4

14 Troubleshooting

Error	Error cause	Troubleshooting
No function	No power supply	Check power supply and connection with product label
	Solenoid coil faulty	Replace solenoid valve
	Plug wrongly connected	Check connection of plug and correct if necessary
	Operating pressure too high	Check operating pressure, reduce if necessary
	Armature blocked	Replace solenoid valve
Solenoid valve leaking	Valve seat leaking	Replace solenoid valve
	PTFE bellows leaking	Replace solenoid valve

15 Removal from piping

WARNING

The equipment is subject to pressure!

- ▶ Risk of severe injury or death
- Depressurize the plant or plant component.
- Completely drain the plant or plant component.

CAUTION



Hot plant components!

- ▶ Risk of burns
- Only work on plant that has cooled down.

1. Allow the plant to cool down.
2. Allow the plant to run empty.
3. Unscrew the electrical wiring.
4. Remove the product from the piping with appropriate measures

16 Disposal

1. Pay attention to adhered residual material and gas diffusion from penetrated media.
2. Dispose of all parts in accordance with the disposal regulations/environmental protection laws.

17 Returns

Legal regulations for the protection of the environment and personnel require that the completed and signed return delivery note is included with the dispatch documents. Returned goods can be processed only when this note is completed. If no return delivery note is included with the product, GEMÜ cannot process credits or repair work but will dispose of the goods at the operator's expense.

1. Clean the product.
2. Request a return delivery note from GEMÜ.
3. Complete the return delivery note.
4. Send the product with a completed return delivery note to GEMÜ.



GEMÜ Gebr. Müller Apparatebau GmbH & Co. KG
Fritz-Müller-Straße 6-8, 74653 Ingelfingen-Criesbach, Germany
Phone +49 (0) 7940 1230 · info@gemue.de
www.gemu-group.com

Subject to alteration

05.2024 | 88593397