

GEMÜ 549 eSyDrive

Motorized angle seat globe valve

EN

Operating instructions



All rights including copyrights or industrial property rights are expressly reserved.

Keep the document for future reference.

© GEMÜ Gebr. Müller Apparatebau GmbH & Co. KG
17.04.2024

Contents

1	General information	4
1.1	Information	4
1.2	Symbols used	4
1.3	LED symbols	4
1.4	Definition of terms	4
1.5	Warning notes	4
2	Safety information	4
3	Product description	5
4	GEMÜ CONEXO	8
5	Order data	9
6	Technical data	11
7	Electrical connection	20
8	Dimensions	23
9	Delivery	36
10	Transport	36
11	Storage	36
12	Installation in piping	36
12.1	Preparing for installation	36
12.2	Installation position	36
12.3	Installation with butt weld spigots	37
12.4	Installation with threaded sockets	37
12.5	Installation with threaded spigots	37
12.6	Installation with flanged connection	37
13	Network connection	38
13.1	Network settings	38
13.2	Connecting the network	38
13.3	Resetting the network settings	38
14	Commissioning	38
14.1	Commissioning on the device	38
14.2	Commissioning via the eSy-Web web interface	38
14.3	Commissioning via digital input	38
15	Operation	38
15.1	Operation on the device	38
15.2	Operation via the web server	38
15.3	Manual override	38
16	Inspection and maintenance	40
16.1	Spare parts	40
16.2	Removing the actuator	40
16.3	Replacing the seals	41
16.4	Mounting the actuator	41
17	Troubleshooting	42
18	Removal from piping	43
19	Disposal	43
20	Returns	43
21	EU Declaration of Incorporation according to the EC Machinery Directive 2006/42/EC, Annex II B ...	44
22	EU Declaration of Conformity in accordance with 2014/68/EU (Pressure Equipment Directive)	45
23	EU Declaration of Conformity in accordance with 2014/30/EU (EMC Directive)	46
24	EU Declaration of Conformity In accordance with 2011/65/EU (RoHS Directive)	47

1 General information

1.1 Information

- The descriptions and instructions apply to the standard versions. For special versions not described in this document the basic information contained herein applies in combination with any additional special documentation.
- Correct installation, operation, maintenance and repair work ensure faultless operation of the product.
- Should there be any doubts or misunderstandings, the German version is the authoritative document.
- Contact us at the address on the last page for staff training information.

1.2 Symbols used

The following symbols are used in this document:

Symbol	Meaning
●	Tasks to be performed
▶	Response(s) to tasks
-	Lists

1.3 LED symbols

The following LED symbols are used in the documentation:

Symbol	LED conditions
○	Off
●	Lit (on)
⦿	Flashing

1.4 Definition of terms

Working medium

The medium that flows through the GEMÜ product.

1.5 Warning notes

Wherever possible, warning notes are organised according to the following scheme:

SIGNAL WORD	
Possible symbol for the specific danger	Type and source of the danger ▶ Possible consequences of non-observance. ● Measures for avoiding danger.

Warning notes are always marked with a signal word and sometimes also with a symbol for the specific danger.

The following signal words and danger levels are used:





⚠ DANGER	
	Imminent danger! ▶ Non-observance can cause death or severe injury.

⚠ WARNING	
	Potentially dangerous situation! ▶ Non-observance can cause death or severe injury.

⚠ CAUTION	
	Potentially dangerous situation! ▶ Non-observance can cause moderate to light injury.

NOTICE	
	Potentially dangerous situation! ▶ Non-observance can cause damage to property.

The following symbols for the specific dangers can be used within a warning note:

Symbol	Meaning
	Danger of explosion!
	Corrosive chemicals!
	Hot plant components!
	Rotating cover!
	Incorrect combination of actuator and valve body!

2 Safety information

The safety information in this document refers only to an individual product. Potentially dangerous conditions can arise in combination with other plant components, which need to be considered on the basis of a risk analysis. The operator is responsible for the production of the risk analysis and for compliance with the resulting precautionary measures and regional safety regulations.

The document contains fundamental safety information that must be observed during commissioning, operation and maintenance. Non-compliance with these instructions may cause:

- Personal hazard due to electrical, mechanical and chemical effects.
- Hazard to nearby equipment.

- Failure of important functions.
- Hazard to the environment due to the leakage of dangerous substances.

The safety information does not take into account:

- Unexpected incidents and events, which may occur during installation, operation and maintenance.
- Local safety regulations which must be adhered to by the operator and by any additional installation personnel.

Prior to commissioning:

1. Transport and store the product correctly.
2. Do not paint the bolts and plastic parts of the product.
3. Carry out installation and commissioning using trained personnel.
4. Provide adequate training for installation and operating personnel.
5. Ensure that the contents of the document have been fully understood by the responsible personnel.
6. Define the areas of responsibility.
7. Observe the safety data sheets.
8. Observe the safety regulations for the media used.

During operation:

9. Keep this document available at the place of use.
10. Observe the safety information.
11. Operate the product in accordance with this document.
12. Operate the product in accordance with the specifications.
13. Maintain the product correctly.
14. Do not carry out any maintenance work and repairs not described in this document without consulting the manufacturer first.

In cases of uncertainty:

15. Consult the nearest GEMÜ sales office.

3 Product description

3.1 Construction

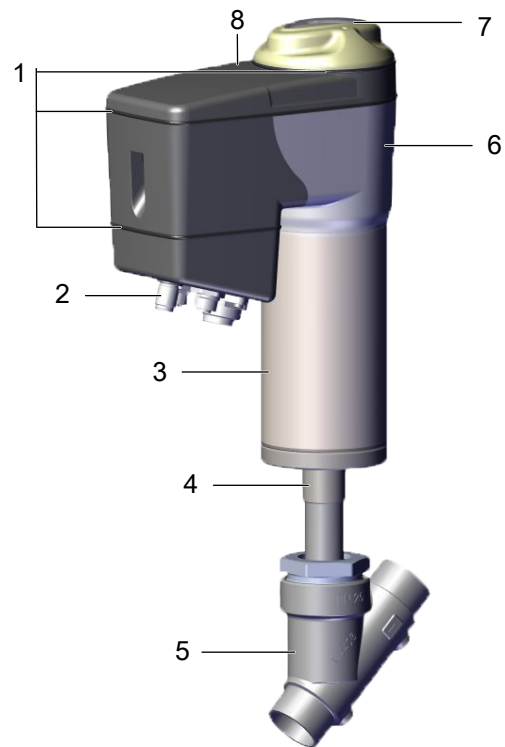

Item	Name	Materials
1	O-rings	EPDM
2	Electrical connections	
3	Actuator base	1.4301 / 1.4305
4	Distance piece with leak detection hole	1.4408
5	Valve body	1.4408, 1.4435
6	Optical position indicator	PESU (Actuator size 0, 2) PC (Actuator size 1)
7	Cover with high visibility LED, manual override and on-site control	PESU (Actuator size 0, 2) PC (Actuator size 1)
8	Actuator top	PESU black (Actuator size 0, 2) PC black (Actuator size 1)

3.2 Buttons for on-site control

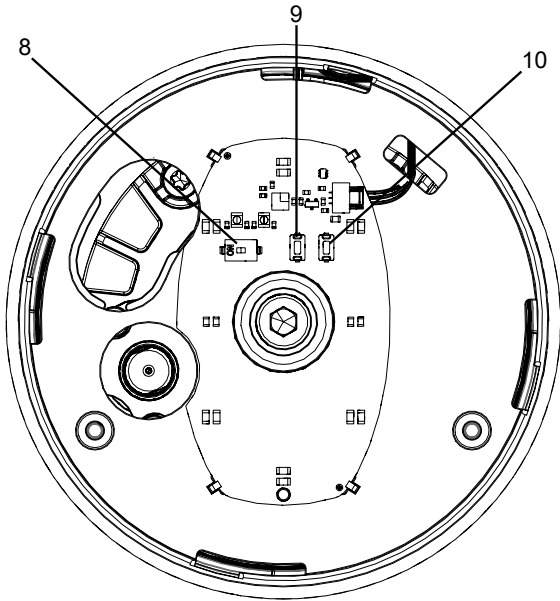

Fig. 1: Position of the buttons

Item	Name	Function
8	DIP switch, "ON-site" control	Switches the on-site control on the device on or off
9	"OPEN" button	Moves actuator to the open position Resets the network settings
10	"INIT/CLOSE" button	Moves actuator to the closed position Starting initialisation

3.3 LED displays

3.3.1 On-site status LEDs

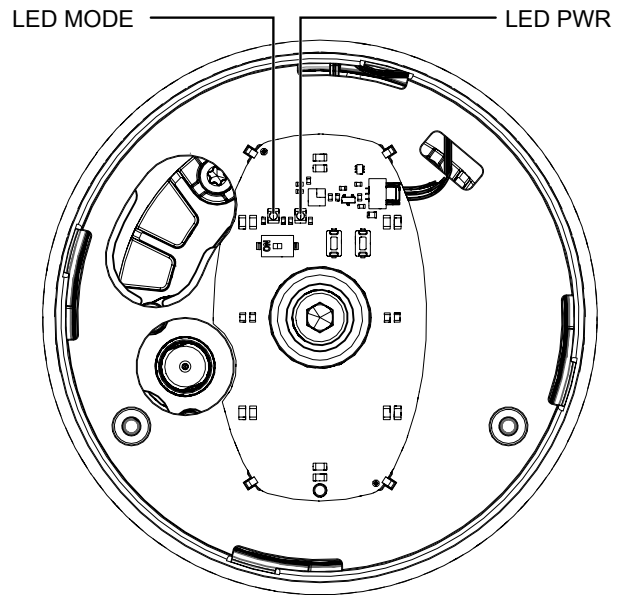



Fig. 2: Position of the status LEDs

The user checks the following conditions directly on-site at the valve using LED MODE and LED PWR:

Function	LED MODE		LED PWR	
	Yellow	Blue	Green	Red
Automatic operation	●	○	●	○
Manual operation	☼	○	●	○
Actuator switched off (OFF mode)	○	○	●	○
Manual operation (on-site)	○	●	●	○
Software update	☼	☼	●	○
	alternating			
On-site initialisation (buttons)	○	☼	●	○
Remote initialisation (via Di-gln)	●	○	●	○

Function	LED MODE		LED PWR	
	Yellow	Blue	Green	Red
Operation via emergency power supply module				

3.3.2 High visibility LEDs

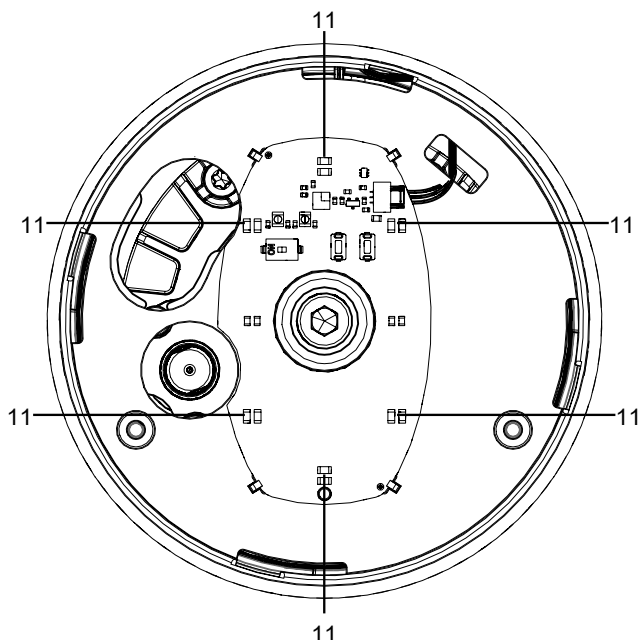





Fig. 3: Position of the high visibility LEDs

Item	Name
11	High visibility LEDs

Function	High visibility LED	
	green	orange
Initialization		
	alternating	
Location function		







Description

The GEMÜ 549 eSyDrive is an electrically operated 2/2-way angle seat globe valve with a hollow shaft electric actuator. The eSyDrive hollow shaft actuator can be operated as On/Off or with integrated positioner or process controller. The valve spindle is sealed by a self-adjusting gland packing. This provides a low-maintenance and reliable valve spindle seal even after an extended period of operation. A wiper ring fitted in front of the gland packing protects the seal against contamination and damage. An integral optical and electrical position indicator is standard.

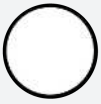
3.4 Function

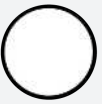
The product controls or regulates (depending on version) a flowing medium by being closed or opened by a motorized actuator.

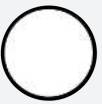
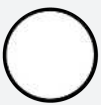
The product has an optical position indicator as standard. The optical position indicator indicates the OPEN and CLOSED positions.

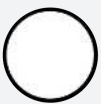
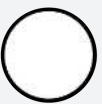
Function		High visibility LED	
		green	orange
OPEN position	Position indicator LEDs standard		
OPEN position	Position indicator LEDs inversed		
CLOSED position	Position indicator LEDs standard		
CLOSED position	Position indicator LEDs inversed		
Position unknown	(e.g. 50%)		

3.5 Correct use

DANGER

Danger of explosion!

- ▶ Risk of death or severe injury
- Do **not** use the product in potentially explosive zones.

WARNING

Improper use of the product!

- ▶ Risk of severe injury or death
- ▶ Manufacturer liability and guarantee will be void.
- Only use the product in accordance with the operating conditions specified in the contract documentation and in this document.

The product is designed for installation in piping systems and for controlling a working medium.

The product is not intended for use in potentially explosive areas.

- Use the product in accordance with the technical data.

3.6 Product label

The product label is located on the actuator. Product label data (example):

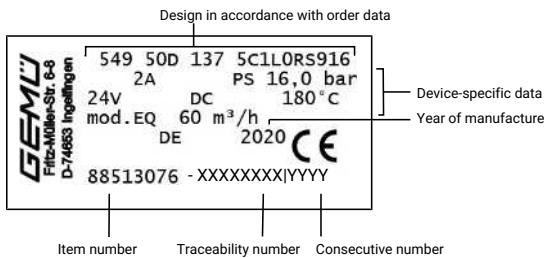

The month of manufacture is encoded in the traceability number and can be obtained from GEMÜ. The product was manufactured in Germany.

The operating pressure stated on the product label applies to a media temperature of 20 °C. The product can be used up to the maximum stated media temperature. You can find the pressure/temperature correlation in the technical data.

4 GEMÜ CONEXO

The interaction of valve components that are equipped with RFID chips and an associated IT infrastructure actively increase process reliability.



Thanks to serialization, every valve and every relevant valve component such as the body, actuator or diaphragm, and even automation components, can be clearly traced and read using the CONEXO pen RFID reader. The CONEXO app, which can be installed on mobile devices, not only facilitates and improves the "installation qualification" process, but also makes the maintenance process much more transparent and easier to document. The app actively guides the maintenance technician through the maintenance schedule and directly provides him with all the information assigned to the valve, such as test reports, testing documentation and maintenance histories. The CONEXO portal acts as a central element, helping to collect, manage and process all data.

For further information on GEMÜ CONEXO please visit:
www.gemu-group.com/conexo

5 Order data

The order data provide an overview of standard configurations.

Please check the availability before ordering. Other configurations available on request.

Order codes

1 Type	Code
Angle seat globe valve, electrically operated, electro-mechanical hollow shaft actuator, eSyDrive	549

2 DN	Code
DN 10	10
DN 15	15
DN 20	20
DN 25	25
DN 32	32
DN 40	40
DN 50	50
DN 65	65
DN 80	80

3 Body configuration	Code
2/2-way body	D
Angle valve body	E

4 Connection type	Code
Spigot	
Spigot DIN	0
Spigot DIN EN 10357 series B (2014 edition; formerly DIN 11850 series 1)	16
Spigot EN 10357 series A/DIN 11866 series A formerly DIN 11850 series 2	17
Spigot SMS 3008	37
Spigot ASME BPE/DIN EN 10357 series C (from 2022 edition)/DIN 11866 series C	59
Spigot ISO 1127/DIN EN 10357 series C (2014 edition)/DIN 11866 series B	60
Spigot ANSI/ASME B36.19M schedule 10s	63
Spigot ANSI/ASME B36.19M schedule 40s	65
Threaded connection	
Threaded socket DIN ISO 228	1
Threaded socket Rc ISO 7-1, EN 10226-2, JIS B 0203, BS 21, end-to-end dimension ETE DIN 3202-4 series M8	3C
Threaded socket NPT, end-to-end dimension ETE DIN 3202-4 series M8	3D
Threaded spigot DIN ISO 228	9
Flange	
Flange EN 1092, PN 25, form B, face-to-face dimension FTF EN 558 series 1, ISO 5752, basic series 1	10
Flange EN 1092, PN 25, form B	13
Flange ANSI Class 150 RF	47
Clamp	
Clamp ASME BPE, face-to-face dimension FTF ASME BPE	80

4 Connection type	Code
Clamp DIN 32676 series B, face-to-face dimension FTF EN 558 series 1	82
Clamp DIN 32676 series A, face-to-face dimension FTF EN 558 series 1	86
Clamp ASME BPE, for pipe ASME BPE, face-to-face dimension FTF EN 558 series 1	88

5 Valve body material	Code
1.4435, investment casting	34
1.4408, investment casting	37
1.4435 (F316L), forged body	40
1.4435, investment casting	C2

6 Seat seal	Code
PTFE	5
PTFE, glass fibre reinforced	5G
1.4404	10

7 Voltage/frequency	Code
24 V DC	C1

8 Control module	Code
OPEN/CLOSE, positioner and process controller	L0

9 Regulating cone	Code
Please find the number of the optional regulating cone (R-No.) for the linear or equal-percentage modified regulating cone in the Kv value table.	R...

10 Actuator version	Code
Actuator size 0	0A
Actuator size 1	1A
Actuator size 2	2A

11 Type of design	Code
Ra ≤ 0.6 µm (25 µinch) for media wetted surfaces, in accordance with ASME BPE SF2 + SF3 mechanically polished internal	1903
Ra ≤ 0.8 µm (30 µinch) for media wetted surfaces, in accordance with DIN 11866 H3, mechanically polished internal	1904
Ra ≤ 0.4 µm (15 µinch) for media wetted surfaces, in accordance with DIN 11866 H4, ASME BPE SF1 mechanically polished internal	1909
for increased temperatures	2024

12 Special version	Code
Special version for oxygen, (max. temperature 60 °C; max. operating pressure 10 bar), flow direction only possible under the seat! Media-wetted seal materials and auxiliary materials with BAM testing	S

13 CONEXO	Code
Without	

13 CONEXO	Code
Integrated RFID chip for electronic identification and traceability	C

Order example

Ordering option	Code	Description
1 Type	549	Angle seat globe valve, electrically operated, electro-mechanical hollow shaft actuator, eSyDrive
2 DN	50	DN 50
3 Body configuration	D	2/2-way body
4 Connection type	1	Threaded socket DIN ISO 228
5 Valve body material	37	1.4408, investment casting
6 Seat seal	5	PTFE
7 Voltage/frequency	C1	24 V DC
8 Control module	L0	OPEN/CLOSE, positioner and process controller
9 Regulating cone	RS916	60 m ³ /h – mod.EQ
10 Actuator version	2A	Actuator size 2
11 Type of design	1903	Ra ≤ 0.6 μm (25 μinch) for media wetted surfaces, in accordance with ASME BPE SF2 + SF3 mechanically polished internal
12 Special version		Standard
13 CONEXO		Without

6 Technical data

6.1 Medium

Working medium: Corrosive, inert, gaseous and liquid media which have no negative impact on the physical and chemical properties of the body and seal material.

Max. permissible viscosity: 600 mm²/s
Other versions for lower / higher temperatures and higher viscosities on request.

6.2 Temperature

Media temperature: -10 – 180 °C
-10 – 250 °C for K-No. 2024 + seat seal Code 5G, Code 10
For material code 37 (and 34 only with 3.2. certificate): -40–180 °C

Ambient temperature: -10 – 60 °C
-10 – 40 °C for K-No. 2024 + seat seal Code 5G, Code 10

Storage temperature: 0 – 40 °C

6.3 Pressure

Operating pressure:

DN	Actuator version 0A	Actuator version 1A	Actuator version 2A
10	0 - 25	-	-
15	0 - 25	-	-
20	0 - 20	0 - 25	-
25	0 - 12	0 - 25	-
32	-	0 - 20	-
40	-	0 - 12	0 - 25
50	-	0 - 8	0 - 16
65	-	0 - 5	0 - 10
80	-	0 - 4	0 - 6

Pressures in bar

All pressures are gauge pressures.

For max. operating pressures the pressure / temperature correlation must be observed.

Higher operating pressures on request

Leakage rate:

Open/Close valve

Seat seal	Standard	Test procedure	Leakage rate	Test medium
Metal	DIN EN 12266-1	P12	F	Air
EPDM, FKM, PTFE	DIN EN 12266-1	P12	A	Air

Control valve

Seat seal	Standard	Test procedure	Leakage rate	Test medium
Metal	DIN EN 60534-4	1	IV	Air
PTFE, FKM, EPDM	DIN EN 60534-4	1	VI	Air

Pressure/temperature correlation:

Connection types code ¹⁾	Material code ²⁾	Max. allowable operating pressures in bar at temperature in °C					
		RT	100	150	200	250	300
1, 9, 17, 37, 60, 63, 3C, 3D	37	25.0	23.8	21.4	18.9	17.5	16.1
0, 16, 17, 37, 59, 60, 65	34	25.0	24.5	22.4	20.3	18.2	16.1
13 (DN 15 - 50)	34	25.0	23.6	21.5	19.8	18.6	17.2
80, 88 (DN 15 - 40)	34	25.0	21.2	19.3*	-	-	-
80, 88 (DN 50 - 80)	34	16.0	16.0	16.0*	-	-	-
82 (DN 15 - 32)	34	25.0	21.2	19.3*	-	-	-
82 (DN 40 - 65)	34	16.0	16.0	16.0*	-	-	-
86 (DN 15 - 40)	34	25.0	21.2	19.3*	-	-	-
86 (DN 50 - 65)	34	16.0	16.0	16.0*	-	-	-
10 (DN 15 - 50)	37	25.0	25.0	22.7	21.0	19.8	18.5
47 (DN 15 - 50)	34	15.9	13.3	12.0	11.1	10.2	9.7
0, 16, 17, 59, 60	40	25.0	20.6	18.7	17.1	15.8	14.8
17, 59, 60	C2	25.0	21.2	19.3	17.9	16.8	15.9

* max. temperature 140 °C

1) Connection type

Code 0: Spigot DIN

Code 1: Threaded socket DIN ISO 228

Code 3C: Threaded socket Rc ISO 7-1, EN 10226-2, JIS B 0203, BS 21, end-to-end dimension ETE DIN 3202-4 series M8

Code 3D: Threaded socket NPT, end-to-end dimension ETE DIN 3202-4 series M8

Code 9: Threaded spigot DIN ISO 228

Code 10: Flange EN 1092, PN 25, form B, face-to-face dimension FTF EN 558 series 1, ISO 5752, basic series 1

Code 13: Flange EN 1092, PN 25, form B

Code 16: Spigot DIN EN 10357 series B (2014 edition; formerly DIN 11850 series 1)

Code 17: Spigot EN 10357 series A/DIN 11866 series A formerly DIN 11850 series 2

Code 37: Spigot SMS 3008

Code 47: Flange ANSI Class 150 RF

Code 59: Spigot ASME BPE/DIN EN 10357 series C (from 2022 edition)/DIN 11866 series C

Code 60: Spigot ISO 1127/DIN EN 10357 series C (2014 edition)/DIN 11866 series B

Code 63: Spigot ANSI/ASME B36.19M schedule 10s

Code 65: Spigot ANSI/ASME B36.19M schedule 40s

Code 80: Clamp ASME BPE, face-to-face dimension FTF ASME BPE

Code 82: Clamp DIN 32676 series B, face-to-face dimension FTF EN 558 series 1

Code 86: Clamp DIN 32676 series A, face-to-face dimension FTF EN 558 series 1

Code 88: Clamp ASME BPE, for pipe ASME BPE, face-to-face dimension FTF EN 558 series 1

2) Valve body material

Code 34: 1.4435, investment casting

Code 37: 1.4408, investment casting

Code 40: 1.4435 (F316L), forged body

Code C2: 1.4435, investment casting

Kv values:**Open/Close valve**

	Butt weld spigot DIN 11850	Butt weld spigot DIN 11866	Threaded socket DIN ISO 228
DN			
10	-	-	-
15	2.4	5.5	5.4
20	-	11.7	10.0
25	-	20.5	15.2
32	-	33.0	23.0
40	-	51.0	41.0
50	-	61.0	68.0
65	-	80.0	80.0
80	-	100.0	100.0

Kv values determined in accordance with DIN EN 60534. The Kv value specifications refer to the largest actuator for the respective nominal size. The Kv values for other product configurations (e.g. other connections or body materials) may differ.

Kv values in m³/h

Control valve:**Standard regulating cone (DIN)**

DN	Kv values	Operating pressure	Actuator version	linear	equal percentage
15	5.0	32.0	0A	RS920	RS930
20	10.0	20.0	0A	RS921	RS931
25	15.0	12.0	0A	RS922	RS932
	15.0	32.0	1A	RS923	RS933
32	24.0	20.0	1A	RS924	RS934
40	38.0	12.0	1A	RS925	RS935
	38.0	20.0	2 A	RS905	RS915
50	50.0	8.0	1A	RS926	RS936
	60.0	20.0	2 A	RS906	RS916
65	60.0	5.0	1A	-	RS937
	60.0	15.0	2 A	-	RS917
80	80.0	4.0	1A	-	RS938
	80.0	6.0	2 A	-	RS918

Kv values in m³/h

Control valve:**Standard regulating cone (ANSI)**

DN	Kv values	Operating pressure	Actuator version	linear	equal percentage
15	2.7	32.0	0A	RS961	RS971
20	6.3	20.0	0A	RS962	RS972
25	13.3	12.0	0A	RS963	RS973
	13.3	32.0	1A	RS964	RS974
40	35.6	12.0	1A	RS965	RS975
	35.6	20.0	2 A	RS945	RS955
50	50.0	8.0	1A	RS966	RS976
	58.0	20.0	2 A	RS946	RS956
65	60.0	5.0	1A	-	RS977
	60.0	15.0	2 A	-	RS957
80	80.0	4.0	1A	-	RS978
	80.0	6.0	2 A	-	RS958

Kv values in m³/h

Control valve:

Standard regulating cone with reduced seat

DN	Kv values	Operating pressure	Actuator version	linear	equal percentage
15	0.10 ¹⁾	25.0	0A	RA204	RA407
	0.16 ¹⁾	25.0	0A	RB210	RA408
	0.25 ¹⁾	25.0	0A	RB211	RB407
	0.40 ¹⁾	25.0	0A	RB212	RB408
	0.63 ¹⁾	25.0	0A	RC207	RC408
	1.00 ¹⁾	25.0	0A	RC208	RC409
	1.60	25.0	0A	RD209	RD409
	2.50 ²⁾	25.0	0A	RE210	RE410
20	1.60	25.0	0A	RD210	RD410
	2.50	25.0	0A	RE211	RE411
	4.00	25.0	0A	RF212	RF412
	6.30 ²⁾	25.0	0A	RG213	RG413
25	2.50	25.0	0A	RE212	RE412
	4.00	25.0	0A	RF213	RF413
	6.30	25.0	0A	RG214	RG414
	10.0 ²⁾	18.0	0A	RH213	RH413
32	4.00	25.0	0A	RF214	RF414
	6.30	25.0	0A	RG215	RG415
	10.00	20.0	0A	RH214	RH414
	16.00	12.0	0A	RJ210	RJ410
40	6.30	25.0	0A	RG216	RG416
	10.00	20.0	0A	RH215	RH415
	16.00	12.0	0A	RJ211	RJ411
	25.00	18.0	1A	RK207	RK407
50	10.00	18.0	0A	RH216	RH416
	16.00	12.0	0A	RJ212	RJ412
	25.00	19.0	1A	RK208	RK408
	40.00	12.0	1A	RM204	RM404

1) metal seated

2) not for connection codes 37, 59, 80, 88

Kv values in m³/h

6.4 Product compliance**Machinery Directive:** 2006/42/EC**Pressure Equipment Directive:** 2014/68/EU

Food: Regulation (EC) No. 1935/2004*
 Regulation (EC) No. 10/2011*
 FDA*
 * depending on version and/or operating parameters

EMC Directive: 2014/30/EU**RoHS Directive:** 2011/65/EU**6.5 Mechanical data****Protection class:** IP 65 acc. to EN 60529

Actuating speed: Actuator version 0A Adjustable, max. 6 mm/s
 Actuator version 1A Adjustable, max. 6 mm/s
 Actuator version 2A Adjustable, max. 4 mm/s
 Actuator version 3A Adjustable, max. 2 mm/s

Weight: **Actuator**
 Actuator version 0A 1.8 kg
 Actuator version 1A 3.0 kg
 Actuator version 2A 9.0 kg

Body

Connection types	0, 16, 17, 37, 59, 60, 63, 65	1, 31, 3B	9	10, 13, 47	80, 82, 86, 88
Valve body	Spigot K514	Threaded socket	Threaded spigot	Flange K514	Clamp
DN					
15	0.24	0.35	0.31	1.80	0.37
20	0.50	0.35	0.50	2.50	0.63
25	0.50	0.35	0.65	3.10	0.63
32	0.90	0.75	1.00	4.60	1.08
40	1.10	0.98	1.30	5.10	1.28
50	1.80	1.70	1.80	7.20	2.07
65	3.40	3.20	3.40	-	3.69
80	4.20	4.10	4.40	-	4.60

Weights in kg

6.6 Actuator duty cycle and service life

Service life:	Control operation - Class C acc. to EN 15714-2 (1,800,000 start-ups and 1200 start-ups per hour). Open / Close duty - Minimum 1,000,000 switching cycles at room temperature and permissible duty cycle.
Duty cycle:	Control operation - Class C acc. to EN 15714-2. Open/Close duty - 100%

6.7 Electrical data

Supply voltage:		Actuator size 0	Actuator size 1	Actuator size 2, 3
	Voltage	U _v = 24 V DC ± 10%		
	Rating	Max. 28 W	Max. 65 W	Max. 120 W
	Reverse battery protection	Yes		

6.7.1 Analogue input signals

6.7.1.1 Set value

Input signal:	0/4 - 20 mA; 0 – 10 V DC (selectable using software)
Input type:	passive
Input resistance:	250 Ω
Accuracy/linearity:	≤ ±0.3% of full flow
Temperature drift:	≤ ±0.1% / 10°K
Resolution:	12 bit
Reverse battery protection:	No
Overload proof:	Yes (up to ± 24 V DC)

6.7.1.2 Process actual value

Input signal:	0/4 - 20 mA; 0 – 10 V DC (selectable using software)
Input type:	passive
Input resistance:	250 Ω
Accuracy/linearity:	≤ ±0.3% of full flow
Temperature drift:	≤ ±0.1% / 10°K
Resolution:	12 bit
Reverse battery protection:	No
Overload proof:	Yes (up to ± 24 V DC)

6.7.2 Digital input signals

Digital inputs:	3
Function:	Can be selected using software
Voltage:	24 V DC
Logic level "1":	>14 V DC
Logic level "0":	< 8 V DC
Input current:	typ. 2.5 mA (at 24 V DC)

6.7.3 Analogue output signals**6.7.3.1 Actual value**

Output signal:	0/4 - 20 mA; 0 – 10 V DC (selectable using software)
Output type:	Active (AD5412)
Accuracy:	$\leq \pm 1\%$ of full flow
Temperature drift:	$\leq \pm 0.1\% / 10^\circ\text{K}$
Load resistor:	$\leq 750\text{ k}\Omega$
Resolution:	10 bit
Overload proof:	Yes (up to $\pm 24\text{ V DC}$)
Short-circuit proof:	Yes

6.7.4 Digital output signals**6.7.4.1 Switching outputs 1 and 2**

Design:	2x make contact, potential-free
Switching voltage:	max. 48 V DC / 48 V AC
Switch rating:	max. 60 W / 2A
Switch points:	Adjustable 0 - 100 %

6.7.4.2 Switching output 3

Function:	Signal fault
Type of contact:	Push-Pull
Switching voltage:	Supply voltage
Switching current:	$\leq 0.1\text{ A}$
Drop voltage:	Max. 2.5 V DC at 0.1 A
Overload proof:	Yes (up to $\pm 24\text{ V DC}$)
Short-circuit proof:	Yes
Pull-Down resistance:	120 k Ω

6.7.5 Communication eSy-Web

Interface:	Ethernet
Function:	Parameterisation via web browser
IP address:	192.168.2.1 alterable via web browser
Subnet screen:	255.255.252.0 alterable via web browser

The actuator and the PC must be in the same network to use the web server. The IP address of the actuator is entered in the web browser and the actuator can then be parametrised. In order to use more than one actuator, a definitive IP address must be assigned to each actuator in the same network.

6.7.6 Communication Modus TCP

Interface:	Modbus TCP
IP address:	192.168.2.1 alterable via web browser
Subnet screen:	255.255.252.0 alterable via web browser
Port:	502

Supported function codes:

	Code Dezimal	Code Hex	Function
	3	0x03	Read Holding Registers
	4	0x04	Read Input Registers
	6	0x06	Write Single Register
	16	0x10	Write Multiple Registers
	23	0x17	Read / Write Multiple Registers

6.7.7 Behaviour in the event of an error

Function:	In the event of an error the valve moves to the error position. Notes: Moving to the error position is only possible with full power supply. This behaviour is not a safety position. The valve must be operated with a GEMÜ 1571 emergency power supply module (see accessories) to ensure the function in case of voltage loss.
Error position:	Closed, open or hold (adjustable via eSy-web web interface).

7 Electrical connection

NOTICE

Appropriate cable socket / appropriate mating connector!

- ▶ The appropriate cable socket and/or appropriate mating connector is included for X1, X3 and X4.
- ▶ The appropriate cable socket and/or appropriate mating connector is **not** included for X2.

NOTICE

Damage to unused plugs due to penetration of humidity!

- ▶ Unused plugs must be covered with the protective caps supplied with the product to ensure IP protection.

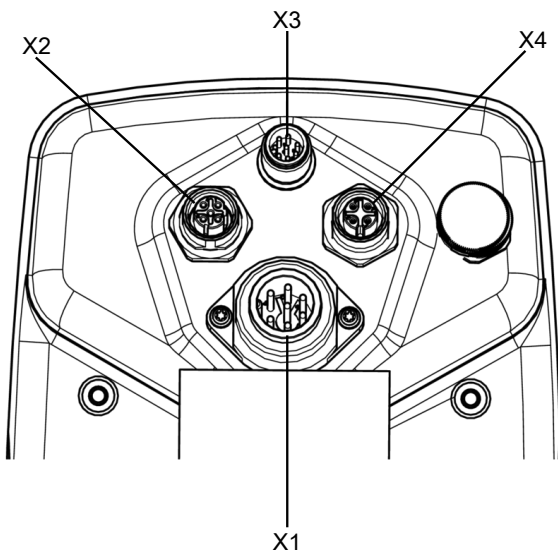
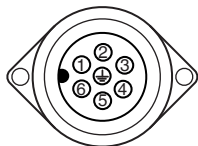

Fig. 4: Overview of electrical connections

7.1 Connection X1



7-pin plug, Binder, type 693

Pin	Signal name
Pin 1	Uv, 24 V DC supply voltage
Pin 2	Uv GND
Pin 3	Relay output K1, common
Pin 4	Relay output K1, make contact
Pin 5	Relay output K2, common
Pin 6	Relay output K2, make contact
Pin PE	Function earth

7.2 Connection X2



5-pin M12 built-in socket, D-coded

Pin	Signal name
Pin 1	Tx + (Ethernet)
Pin 2	Rx + (Ethernet)
Pin 3	Tx - (Ethernet)
Pin 4	Rx - (Ethernet)
Pin 5	Shield

7.3 Connection X3

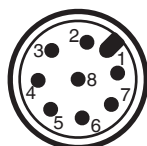

8-pin M12 plug, A-coded

Pin	Signal name
Pin 1	W+ set value input
Pin 2	W – set value input
Pin 3	X + actual value output
Pin 4	GND (actual value output, digital input 1 – 3, error message output)
Pin 5	Error message output 24 V DC
Pin 6	Digital input 3
Pin 7	Digital input 1
Pin 8	Digital input 2

7.4 Connection X4



4-pin M12 built-in socket, A-coded

Pin	Signal name
Pin 1	UV, 24 V DC actual value supply
Pin 2	n.c.
Pin 3	GND (actual value supply, actual value input)
Pin 4	X+, process actual value input
Pin 5	n.c.

7.5 Connecting the product electrically

1. Protect the electrical connections from direct contact with rain water.
2. Lay the cables and pipework so that neither condensate nor rain water can get into the plug unions.
3. Check that all plug cable glands and fittings are mechanically secured.
 - ⇒ The cable must be held firmly on all sides.
4. Check whether the actuator cover/manual override is closed and undamaged.
5. Correctly close the actuator cover/manual override again immediately after use (see "Manual override", page 38).
6. Correctly close the product again after replacing the diaphragm.

7.6 Connection diagram

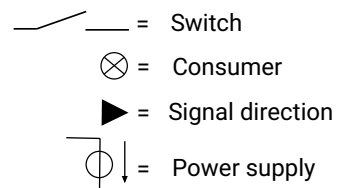
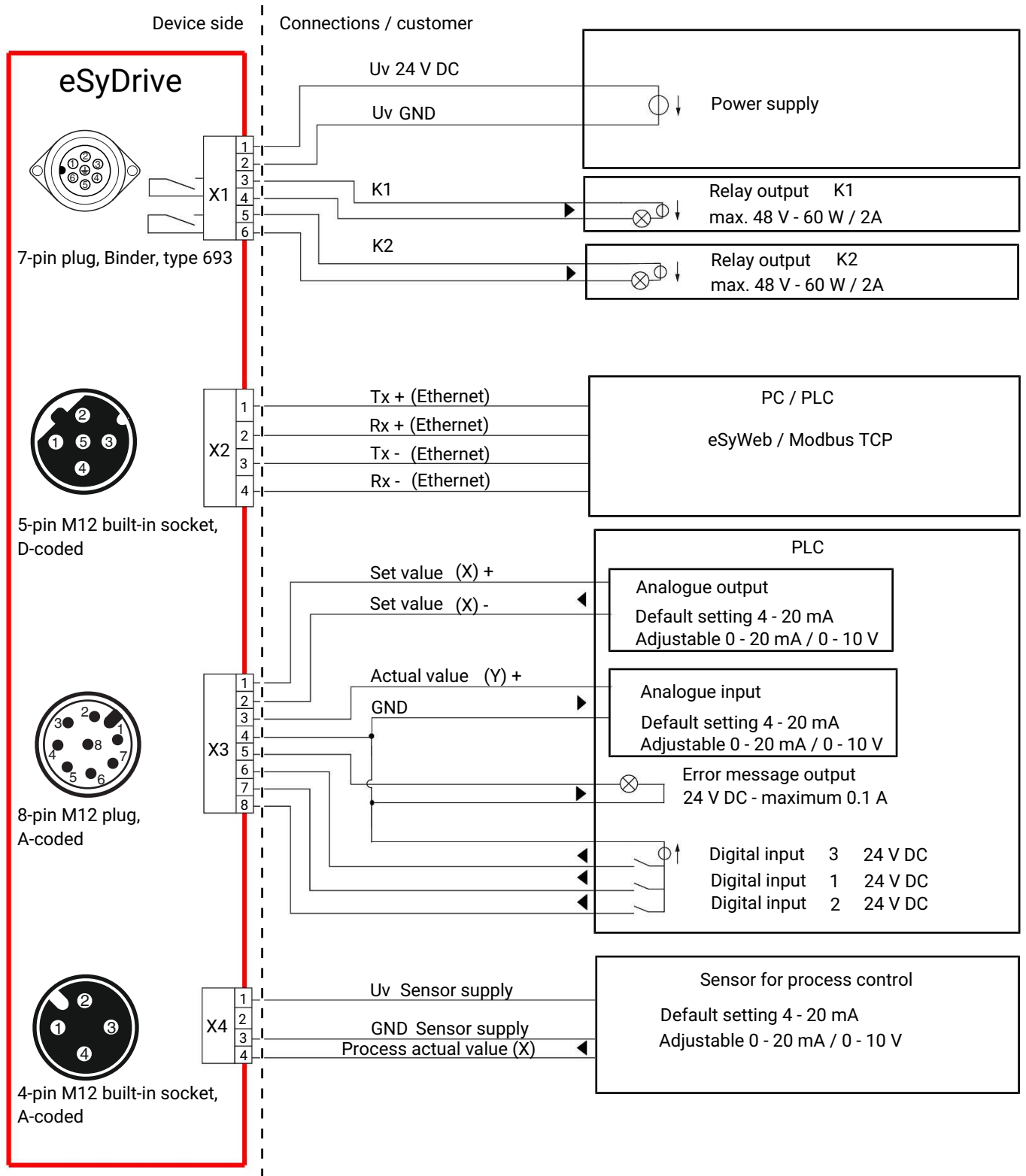

8 Dimensions

8.1 Installation dimensions - Valve with 2/2-way body

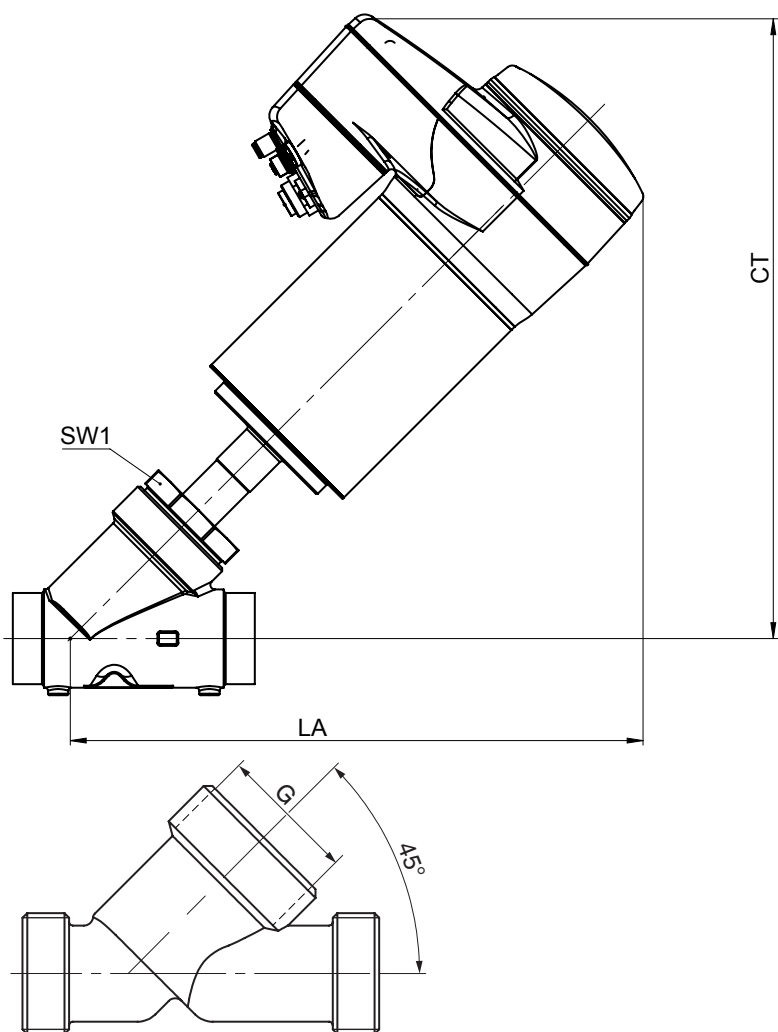

DN	SW1	G	Actuator version 0A		Actuator version 1A		Actuator version 2A	
			CT	LA	CT	LA	CT	LA
10	36	-	287.0	242.0	-	-	-	-
15	36	M 34x1.5	290.0	245.0	-	-	-	-
20	41	M 40x1.5	300.0	255.0	341.0	299.0	-	-
25	46	M 45x1.5	300.0	255.0	341.0	299.0	-	-
32	55	M 52x1.5	-	-	349.0	307.0	402.0	368.0
40	60	M 60x2.0	-	-	354.0	312.0	407.0	373.0
50	75	M 72x2.0	-	-	362.0	320.0	405.0	381.0
65	75	M 90x2.0	-	-	375.0	333.0	428.0	394.0
80	75	M 105x2.0	-	-	-	-	445.0	411.0

Dimensions in mm

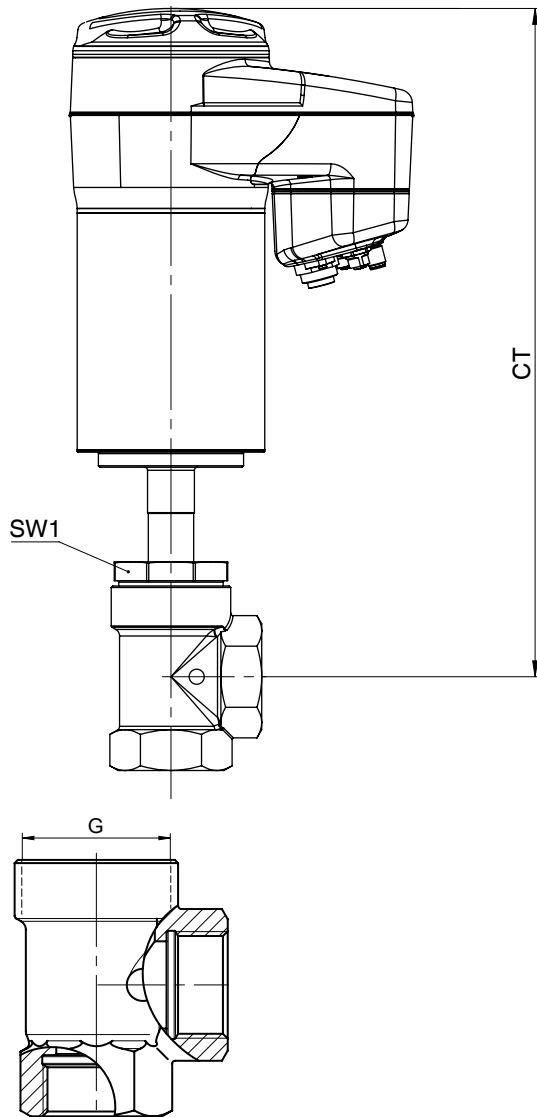
8.2 Installation dimensions - Valve with angle valve body

DN	SW1	G	CT			
			Actuator version			
			0A	1A	2A	3A
15	36	M 34x1.5	293.0	-	-	-
20	41	M 40x1.5	296.0	353.0	-	-
25	46	M 45x1.5	300.0	357.0	-	-
32	55	M 52x1.5	-	360.0	429.0	-
40	60	M 60x2.0	-	365.0	434.0	-
50	75	M 72x2.0	-	372.0	441.0	464.0

Dimensions in mm

8.3 Actuator dimensions

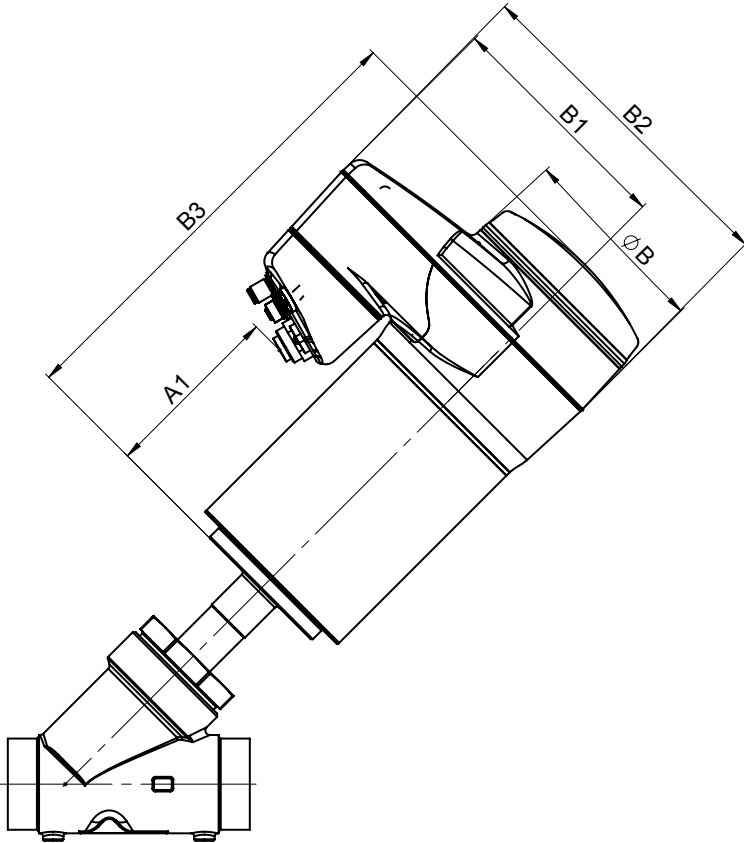

Actuator version	A1	B	B1	B2	B3
0A	45.0	68.0	126.0	160.0	193.0
1A	86.0	82.0	132.0	172.0	252.0
2A	121.0	129.0	157.0	224.0	304.0

Dimensions in mm

8.4 Body dimensions

8.4.1 Spigot DIN/EN/ISO/ANSI/ASME/SMS (code 0, 16, 17, 37, 59, 60, 65)

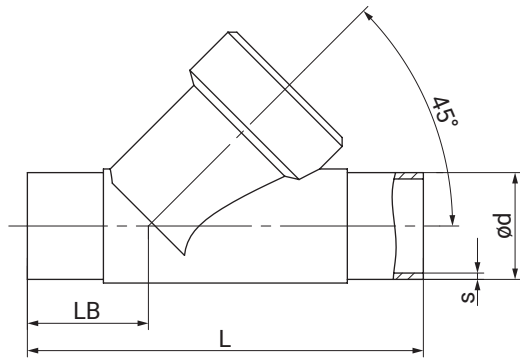

Connection type spigot DIN/EN/ISO (code 0, 16, 17, 60), investment casting material (code 34)¹⁾

DN	NPS	ød				L	LB	s			
		Connection type						Connection type			
		0	16	17	60			0	16	17	60
10	3/8"	-	12.0	13.0	17.2	105.0	35.5	-	1.0	1.5	1.6
15	1/2"	18.0	18.0	19.0	21.3	105.0	35.5	1.5	1.0	1.5	1.6
20	3/4"	22.0	22.0	23.0	26.9	120.0	39.0	1.5	1.0	1.5	1.6
25	1"	28.0	28.0	29.0	33.7	125.0	38.5	1.5	1.0	1.5	2.0
32	1¼"	-	34.0	35.0	42.4	155.0	48.0	-	1.0	1.5	2.0
40	1½"	40.0	40.0	41.0	48.3	160.0	47.0	1.5	1.0	1.5	2.0
50	2"	52.0	52.0	53.0	60.3	180.0	48.0	1.5	1.0	1.5	2.0

Connection type spigot ANSI/ASME/SMS (code 37, 59, 65)²⁾, investment casting material (code 34)¹⁾

DN	NPS	ød			L	LB	s		
		Connection type					Connection type		
		37	59	65			37	59	65
15	1/2"	-	12.70	21.3	105.0	35.5	-	1.65	2.77
20	3/4"	-	19.05	26.7	120.0	39.0	-	1.65	2.87
25	1"	25.0	25.40	33.4	125.0	38.5	1.2	1.65	3.88
32	1¼"	-	-	42.4	155.0	48.0	-	-	3.56
40	1½"	38.0	38.10	48.3	160.0	47.0	1.2	1.65	3.68
50	2"	51.0	50.80	60.3	180.0	48.0	1.2	1.65	3.91

Dimensions in mm

1) **Valve body material**

Code 34: 1.4435, investment casting

2) **Connection type**

Code 0: Spigot DIN

Code 16: Spigot DIN EN 10357 series B (2014 edition; formerly DIN 11850 series 1)

Code 17: Spigot EN 10357 series A/DIN 11866 series A formerly DIN 11850 series 2

Code 37: Spigot SMS 3008

Code 59: Spigot ASME BPE/DIN EN 10357 series C (from 2022 edition)/DIN 11866 series C

Code 60: Spigot ISO 1127/DIN EN 10357 series C (2014 edition)/DIN 11866 series B

Code 65: Spigot ANSI/ASME B36.19M schedule 40s

8.4.2 Spigot EN/ISO/ANSI/ASME/SMS (code 17, 37, 59, 60, 63)

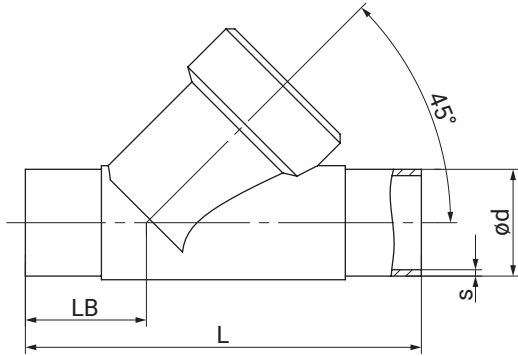

Connection type spigot EN/ISO/ASME (code 17, 60), investment casting material (code 37)¹⁾

DN	NPS	ød		L	LB	s	
		Connection type				Connection type	
		17	60			17	60
15	1/2"	19.0	21.3	100.0	33.0	1.5	1.6
20	3/4"	23.0	26.9	108.0	33.0	1.5	1.6
25	1"	29.0	33.7	112.0	32.0	1.5	2.0
32	1¼"	35.0	42.4	137.0	39.0	1.5	2.0
40	1½"	41.0	48.3	146.0	40.0	1.5	2.0
50	2"	53.0	60.3	160.0	38.0	1.5	2.0
65	2½"	70.0	76.1	290.0	96.0	2.0	2.0
80	3"	85.0	88.9	310.0	95.0	2.0	2.3

Connection type spigot ASME/SMS (code 37, 59)²⁾, investment casting material (code 37)¹⁾

DN	NPS	ød		L	LB	s	
		Connection type				Connection type	
		37	59			37	59
65	2½"	63.5	63.5	290.0	96.0	1.6	1.65
80	3"	76.1	76.0	310.0	95.0	1.6	1.65

Dimensions in mm

1) Valve body material

Code 37: 1.4408, investment casting

2) Connection type

Code 17: Spigot EN 10357 series A/DIN 11866 series A formerly DIN 11850 series 2

Code 37: Spigot SMS 3008

Code 59: Spigot ASME BPE/DIN EN 10357 series C (from 2022 edition)/DIN 11866 series C

Code 60: Spigot ISO 1127/DIN EN 10357 series C (2014 edition)/DIN 11866 series B

Code 63: Spigot ANSI/ASME B36.19M schedule 10s

8.4.3 Spigot EN/ISO/ASME (code 17, 59, 60)

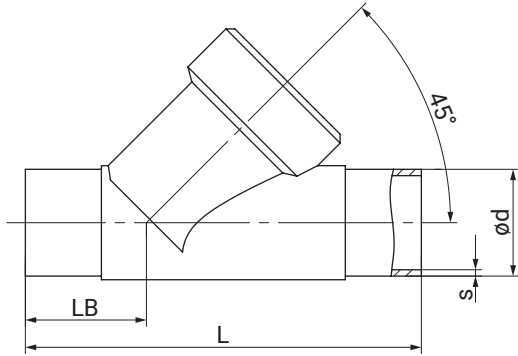

Connection type spigot EN/ISO/ASME (code 17, 59, 60)¹⁾, investment casting material (code C2)

DN	NPS	ød			L	LB	s		
		Connection type					Connection type		
		17	59	60			17	59	60
10	3/8"	13.0	-	17.2	105.0	35.5	1.5	-	1.6
15	1/2"	19.0	12.70	21.3	105.0	35.5	1.5	1.65	1.6
20	3/4"	23.0	19.05	26.9	120.0	39.0	1.5	1.65	1.6
25	1"	29.0	25.40	33.7	125.0	39.5	1.5	1.65	2.0
32	1¼"	35.0	-	42.4	155.0	48.0	1.5	-	2.0
40	1½"	41.0	38.10	48.3	160.0	47.0	1.5	1.65	2.0
50	2"	53.0	50.80	60.3	180.0	48.0	1.5	1.65	2.0
65	2½"	70.0	63.50	76.1	290.0	96.0	2.0	1.65	2.0
80	3"	85.0	76.20	88.9	310.0	95.0	2.0	1.65	2.3

Dimensions in mm

1) Connection type

Code 17: Spigot EN 10357 series A/DIN 11866 series A formerly DIN 11850 series 2

Code 59: Spigot ASME BPE/DIN EN 10357 series C (from 2022 edition)/DIN 11866 series C

Code 60: Spigot ISO 1127/DIN EN 10357 series C (2014 edition)/DIN 11866 series B

8.4.4 Threaded socket DIN/Rc/NPT body configuration D (code 1, 3C, 3D)

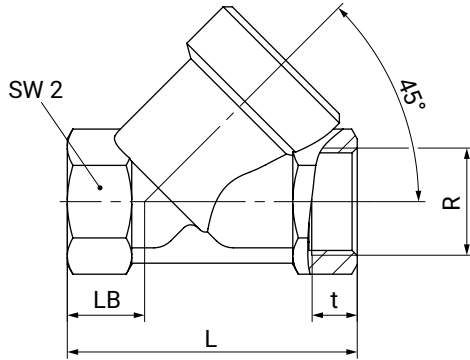

Connection type threaded socket DIN (code 1)¹⁾, investment casting material (code 37)²⁾

DN	NPS	L	LB	R	SW2	t
10	3/8"	65.0	16.5	G 3/8	27	11.4
15	1/2"	65.0	16.5	G 1/2	27	15.0
20	3/4"	75.0	17.5	G 3/4	32	16.3
25	1"	90.0	24.0	G 1	41	19.1
32	1 1/4"	110.0	33.0	G 1 1/4	50	21.4
40	1 1/2"	120.0	30.0	G 1 1/2	55	21.4
50	2"	150.0	40.0	G 2	70	25.7
65	2 1/2"	190.0	46.0	G 2 1/2	85	30.2
80	3"	220.0	50.0	G 3	100	33.3

Connection type threaded socket Rc/NPT (code 3C, 3D)¹⁾, investment casting material (code 37)²⁾

DN	NPS	L	LB	R		SW2	t	
				Connection type			Connection type	
				3C	3D		3C	3D
15	1/2"	65.0	16.5	Rc 1/2	1/2" NPT	27	15.0	13.6
20	3/4"	75.0	17.5	Rc 3/4	3/4" NPT	32	16.3	14.1
25	1"	90.0	24.0	Rc 1	1" NPT	41	19.1	17.0
32	1 1/4"	110.0	33.0	Rc 1 1/4	1 1/4" NPT	50	21.4	17.5
40	1 1/2"	120.0	30.0	Rc 1 1/2	1 1/2" NPT	55	21.4	17.3
50	2"	150.0	40.0	Rc 2	2" NPT	70	25.7	17.8
65	2 1/2"	190.0	46.0	Rc 2 1/2	2 1/2" NPT	85	30.2	23.7
80	3"	220.0	50.0	Rc 3	3" NPT	100	33.3	25.8

Dimensions in mm

1) **Connection type**

Code 1: Threaded socket DIN ISO 228

Code 3C: Threaded socket Rc ISO 7-1, EN 10226-2, JIS B 0203, BS 21, end-to-end dimension ETE DIN 3202-4 series M8

Code 3D: Threaded socket NPT, end-to-end dimension ETE DIN 3202-4 series M8

2) **Valve body material**

Code 37: 1.4408, investment casting

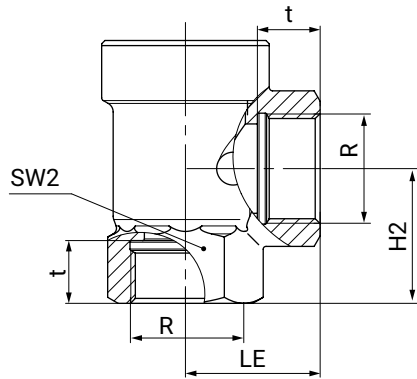
8.4.5 Threaded socket DIN/NPT body configuration E (code 1, 3D)**Connection type threaded socket DIN/NPT (code 1, 3D)¹⁾, investment casting material (code 37)²⁾**

DN	NPS	H2	LE	SW2	R		t	
					Connection type		Connection type	
					1	3D	1	3D
15	1/2"	30.0	30.0	27	G 1/2	1/2" NPT	15.0	13.6
20	3/4"	37.5	35.0	32	G 3/4	3/4" NPT	16.3	14.1
25	1"	41.0	41.0	41	G 1	1" NPT	19.1	17.0
32	1 1/4"	48.0	50.0	50	G 1 1/4	1 1/4" NPT	21.4	17.5
40	1 1/2"	55.0	50.0	55	G 1 1/2	1 1/2" NPT	21.4	17.3
50	2"	62.0	60.0	70	G 2	2" NPT	25.7	17.8

Dimensions in mm

1) Connection type

Code 1: Threaded socket DIN ISO 228

Code 3D: Threaded socket NPT, end-to-end dimension ETE DIN 3202-4 series M8

2) Valve body material

Code 37: 1.4408, investment casting

8.4.6 Threaded spigot DIN (code 9)

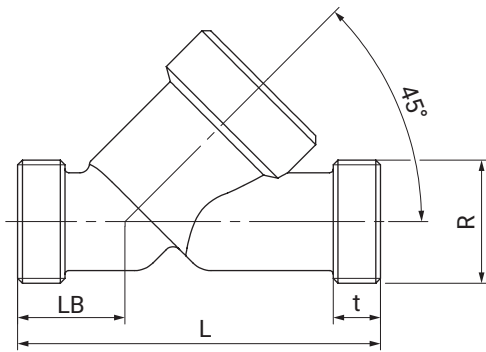

Connection type threaded spigot DIN (code 9)¹⁾, investment casting material (code 37)²⁾

DN	L	LB	R	t
15	90.0	25.0	G 3/4	12.0
20	110.0	30.0	G 1	15.0
25	118.0	30.0	G 1¼	15.0
32	130.0	38.0	G 1½	13.0
40	140.0	35.0	G 1¾	13.0
50	175.0	50.0	G 2⅝	15.0
65	216.0	52.0	G 3	15.0
80	254.0	64.0	G 3½	18.0

Dimensions in mm

- 1) **Connection type**
Code 9: Threaded spigot DIN ISO 228
- 2) **Valve body material**
Code 37: 1.4408, investment casting

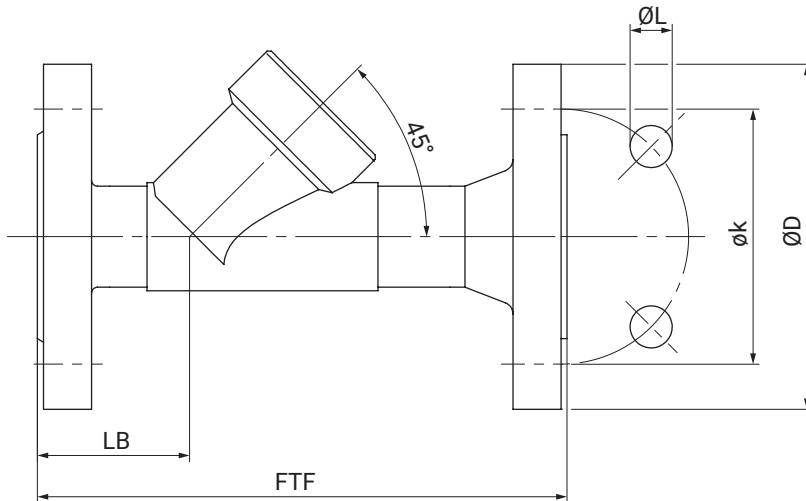
8.4.7 Flange EN (code 10)

Connection type flange EN (code 10)¹⁾, investment casting material (code 37)²⁾

DN	NPS	$\varnothing D$	FTF	$\varnothing k$	$\varnothing L$	LB	n
15	1/2"	95.0	130.0	65.0	14.0	33.0	4
20	3/4"	105.0	150.0	75.0	14.0	45.0	4
25	1"	115.0	160.0	85.0	14.0	44.0	4
32	1¼"	140.0	180.0	100.0	18.0	51.0	4
40	1½"	150.0	200.0	110.0	18.0	52.0	4
50	2"	165.0	230.0	125.0	18.0	50.0	4

Dimensions in mm

n = number of bolts

1) **Connection type**

Code 10: Flange EN 1092, PN 25, form B, face-to-face dimension FTF EN 558 series 1, ISO 5752, basic series 1

2) **Valve body material**

Code 37: 1.4408, investment casting

8.4.8 Flange, special length EN/ANSI (code 13, 47)

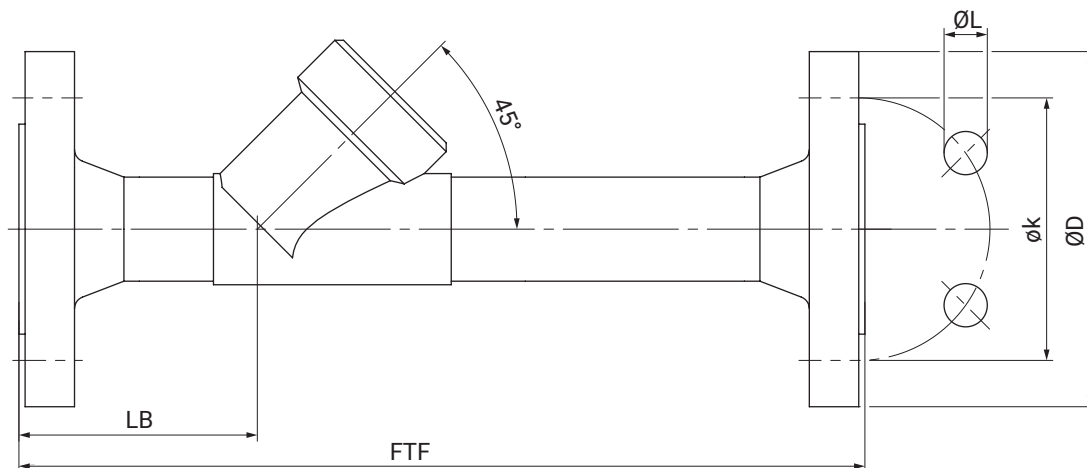

Connection type flange, special length EN/ANSI (code 13, 47)¹⁾, investment casting material (code 34)²⁾

DN	NPS	ØD		FTF	Øk		ØL		LB	n
		Connection type			Connection type		Connection type			
		13	47		13	47	13	47		
15	1/2"	95.0	89.0	210.0	65.0	60.5	14.0	15.7	72.0	4
20	3/4"	105.0	98.6	280.0	75.0	69.8	14.0	15.7	78.0	4
25	1"	115.0	108.0	280.0	85.0	79.2	14.0	15.7	77.0	4
32	1 1/4"	140.0	117.3	310.0	100.0	88.9	18.0	15.7	89.0	4
40	1 1/2"	150.0	127.0	320.0	110.0	98.6	18.0	15.7	91.0	4
50	2"	165.0	152.4	330.0	125.0	120.7	18.0	19.1	95.0	4

Dimensions in mm

n = number of bolts

1) **Connection type**

Code 13: Flange EN 1092, PN 25, form B

Code 47: Flange ANSI Class 150 RF

2) **Valve body material**

Code 34: 1.4435, investment casting

8.4.9 Clamp DIN/ASME (code 80, 82, 86, 88)

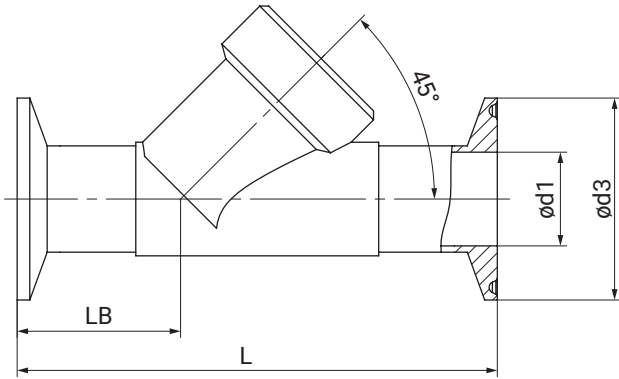

Connection type clamp DIN/ASME (code 80, 82, 86, 88)¹⁾, investment casting material (code 34)²⁾

DN	NPS	ød1				ød3				L				LB			
		Connection type				Connection type				Connection type				Connection type			
		80	82	86	88	80	82	86	88	80	82	86	88	80	82	86	88
15	1/2"	9.40	18.1	16.0	9.40	25.0	50.5	34.0	25.0	101.6	130.0	130.0	130.0	33.5	47.5	47.5	47.5
20	3/4"	15.75	23.7	20.0	15.75	25.0	50.5	34.0	25.0	101.6	150.0	150.0	150.0	30.0	54.0	54.0	54.0
25	1"	22.10	29.7	26.0	22.10	50.5	50.5	50.5	50.5	114.3	160.0	160.0	160.0	33.0	56.0	56.0	56.0
32	1 1/4"	-	38.4	32.0	-	-	64.0	50.5	-	-	180.0	180.0	-	-	62.0	62.0	-
40	1 1/2"	34.80	44.3	38.0	34.80	50.5	64.0	50.5	50.5	139.7	200.0	200.0	200.0	37.0	67.0	67.0	67.0
50	2"	47.50	56.3	50.0	47.50	64.0	77.5	64.0	64.0	158.8	230.0	230.0	230.0	36.5	73.0	73.0	73.0

Dimensions in mm

1) Connection type

- Code 80: Clamp ASME BPE, face-to-face dimension FTF ASME BPE
- Code 82: Clamp DIN 32676 series B, face-to-face dimension FTF EN 558 series 1
- Code 86: Clamp DIN 32676 series A, face-to-face dimension FTF EN 558 series 1
- Code 88: Clamp ASME BPE, for pipe ASME BPE, face-to-face dimension FTF EN 558 series 1

2) Valve body material

- Code 34: 1.4435, investment casting

8.4.10 Clamp DIN/ASME (code 82, 86, 88)

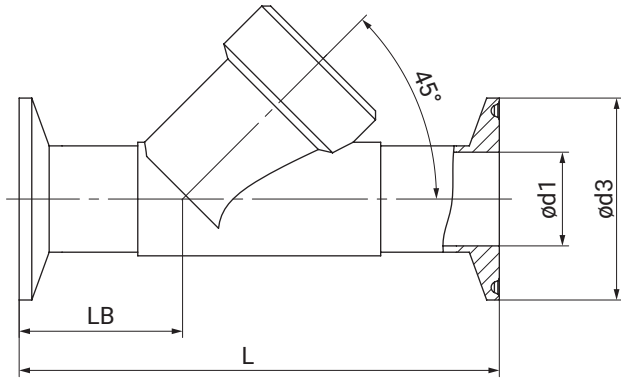

Connection type clamp DIN/ASME (code 82, 86, 88)¹⁾, investment casting material (code C2)²⁾

DN	NPS	ød1			ød3			L	LB
		Connection type			Connection type				
		82	86	88	82	86	88		
15	1/2"	18.1	16.0	9.40	50.5	34.0	25.0	130.0	47.5
20	3/4"	23.7	20.0	15.75	50.5	34.0	25.0	150.0	54.0
25	1"	29.7	26.0	22.10	50.5	50.5	50.5	160.0	56.0
32	1¼"	38.4	32.0	-	64.0	50.5	-	180.0	62.0
40	1½"	44.3	38.0	34.80	64.0	50.5	50.5	200.0	67.0
50	2"	56.3	50.0	47.50	77.5	64.0	64.0	230.0	73.0
65	2½"	72.1	66.0	60.20	91.0	91.0	77.5	290.0	120.0
80	3"	84.3	81.0	72.90	106.0	106.0	91.0	310.0	119.0

Dimensions in mm

1) **Connection type**

Code 82: Clamp DIN 32676 series B, face-to-face dimension FTF EN 558 series 1

Code 86: Clamp DIN 32676 series A, face-to-face dimension FTF EN 558 series 1

Code 88: Clamp ASME BPE, for pipe ASME BPE, face-to-face dimension FTF EN 558 series 1

2) **Valve body material**

Code C2: 1.4435, investment casting

9 Delivery

- Check that all parts are present and check for any damage immediately upon receipt.

The product's performance is tested at the factory. The scope of delivery is apparent from the dispatch documents and the design from the order number.

10 Transport

1. Only transport the product by suitable means. Do not drop. Handle carefully.
2. After the installation dispose of transport packaging material according to relevant local or national disposal regulations / environmental protection laws.

11 Storage

1. Store the product free from dust and moisture in its original packaging.
2. Avoid UV rays and direct sunlight.
3. Do not exceed the maximum storage temperature (see chapter "Technical data").
4. Do not store solvents, chemicals, acids, fuels or similar fluids in the same room as GEMÜ products and their spare parts.

12 Installation in piping

12.1 Preparing for installation

 **WARNING**

The equipment is subject to pressure!

- ▶ Risk of severe injury or death
- Depressurize the plant or plant component.
- Completely drain the plant or plant component.

 **WARNING**



Corrosive chemicals!

- ▶ Risk of caustic burns
- Wear appropriate protective gear.
- Completely drain the plant.

 **CAUTION**



Hot plant components!

- ▶ Risk of burns
- Only work on plant that has cooled down.

 **CAUTION**

Exceeding the maximum permissible pressure!

- ▶ Damage to the product
- Provide precautionary measures against exceeding the maximum permitted pressures caused by pressure surges (water hammer).

 **CAUTION**

Use as step!

- ▶ Damage to the product
- ▶ Risk of slipping-off
- Choose the installation location so that the product cannot be used as a foothold.
- Do not use the product as a step or a foothold.

NOTICE

Suitability of the product!

- ▶ The product must be appropriate for the piping system operating conditions (medium, medium concentration, temperature and pressure) and the prevailing ambient conditions.

NOTICE

Tools!

- ▶ The tools required for installation and assembly are not included in the scope of delivery.
- Use appropriate, functional and safe tools.

1. Ensure the product is suitable for the relevant application.
2. Check the technical data of the product and the materials.
3. Keep appropriate tools ready.
4. Wear appropriate protective gear, as specified in the plant operator's guidelines.
5. Observe appropriate regulations for connections.
6. Have installation work carried out by trained personnel.
7. Shut off plant or plant component.
8. Secure plant or plant component against recommissioning.
9. Depressurize the plant or plant component.
10. Completely drain the plant (or plant component) and let it cool down until the temperature is below the media vaporization temperature and cannot cause scalding.
11. Correctly decontaminate, rinse and ventilate the plant or plant component.
12. Lay piping so that the product is protected against transverse and bending forces, and also from vibrations and tension.
13. Only install the product between matching aligned pipes (see chapters below).
14. Please note the flow direction.
15. Please note the installation position (see chapter "Installation position").

12.2 Installation position

GEMÜ recommend installing the actuator vertically upright or vertically down to optimise the service life.

12.3 Installation with butt weld spigots

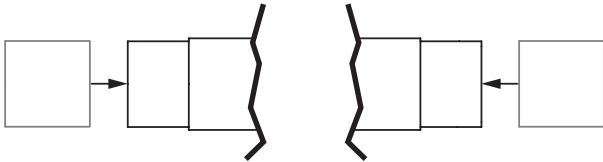

Fig. 5: Butt weld spigots

1. Carry out preparations for installation (see chapter "Preparing for installation").
2. Adhere to good welding practices!
3. Disassemble the actuator with the diaphragm before welding in the valve body (see "Removing the actuator" chapter).
4. Weld the body of the product in the piping.
5. Allow butt weld spigots to cool down.
6. Reassemble the valve body and the actuator with diaphragm (see "Mounting the actuator" chapter).
7. Re-attach or reactivate all safety and protective devices.
8. Flush the system.

12.4 Installation with threaded sockets

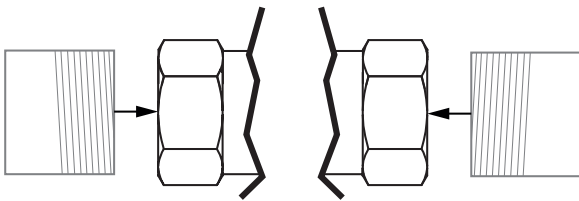

Fig. 6: Threaded socket

NOTICE

Sealing material!

- ▶ The sealing material is not included in the scope of delivery.
- Only use appropriate sealing material.

1. Keep thread sealant ready.
2. Carry out preparations for installation (see chapter "Preparing for installation").
3. Screw the threaded connections into the pipe in accordance with valid standards.
4. Screw the body of the product onto the piping using appropriate thread sealant.
5. Re-attach or reactivate all safety and protective devices.

12.5 Installation with threaded spigots

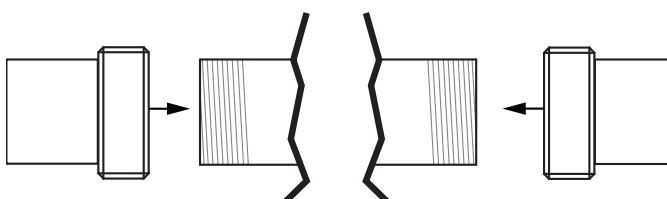

Fig. 7: Threaded spigots

NOTICE

Thread sealant!

- ▶ The thread sealant is not included in the scope of delivery.
- Only use appropriate thread sealant.

1. Keep thread sealant ready.
2. Carry out preparations for installation (see chapter "Preparing for installation").
3. Screw the pipe into the threaded connection of the valve body in accordance with valid standards.
 - ⇒ Use appropriate thread sealant.
4. Re-attach or reactivate all safety and protective devices.

12.6 Installation with flanged connection

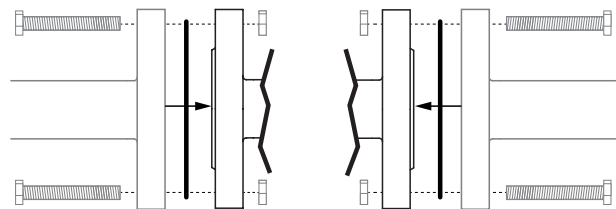

Fig. 8: Flanged connection

NOTICE

Sealing material!

- ▶ The sealing material is not included in the scope of delivery.
- Only use appropriate sealing material.

NOTICE

Connector elements!

- ▶ The connector elements are not included in the scope of delivery.
- Only use connector elements made of approved materials.
- Observe permissible tightening torque of the bolts.

1. Keep sealing material ready.
2. Carry out preparations for installation (see chapter "Preparing for installation").
3. Ensure clean, undamaged sealing surfaces on the connection flanges.
4. Align flanges carefully before installing them.
5. Clamp the product centrally between the piping with flanges.
6. Centre the gaskets.
7. Connect the valve flange and the piping flange using appropriate sealing materials and matching bolting.
8. Use all flange holes.
9. Tighten the bolts diagonally.

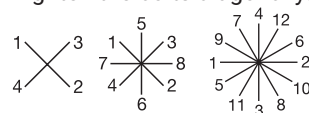

10. Re-attach or reactivate all safety and protective devices.

13 Network connection

13.1 Network settings

The network interface has the following default settings:

IP address: 192.168.2.1

Subnet screen: 255.255.252.0

The default settings can be changed. See the eSy-Web operating instructions.

13.2 Connecting the network

1. Connect the network plug and cables with the electrical connection X2 of the product.
2. Change the IP address using the web server.

13.3 Resetting the network settings

1. Ensure that the "ON-Site" DIP switch **8** is not in the "ON" position.
2. Press and hold down the "OPEN" button **9** for at least 8 s.
 - ⇒ LED 1 flashes fast in blue.
3. Press the "INIT/CLOSE" button **10**.
 - ⇒ Network settings are reset in the default settings.

14 Commissioning

14.1 Commissioning on the device

1. Ensure that the "ON-Site" DIP switch **8** is not in the "ON" position (see "Buttons for on-site control", page 6).
 2. Press and hold down the "INIT/CLOSE" button **10** for at least 8 s.
 - ⇒ Initialization of the actuator begins.
 3. Green and orange LEDs flash alternately.
 - ⇒ Initialization is completed.
- ⇒ Commissioning is completed.

14.2 Commissioning via the eSy-Web web interface

- See separate eSy-Web operating instructions.

14.3 Commissioning via digital input

- ✓ The function of input 3 is set to init.
1. Apply 24 V DC signal briefly (max. 2 s) to connection X3 pin 6 (reference GND connection X3 pin 4).
 - ⇒ Initialization of the actuator begins.
 2. Green and orange LEDs flash alternately.
 - ⇒ Initialization is completed.
- ⇒ Commissioning is completed.

15 Operation

15.1 Operation on the device

15.1.1 Moving the valve to the open position

1. Move the "ON-Site" DIP switch **8** to the "ON" position (see "Buttons for on-site control", page 6).
 - ⇒ Control on the device is activated.
 2. Press the "OPEN" button **9**.
 - ⇒ The valve moves slowly to the open position.
 3. Also press the "INIT/CLOSE" button **10**.
 - ⇒ The valve moves quickly to the open position.
 - ⇒ If the valve is fully opened, the high visibility LEDs are lit in green.
 4. Move the "ON-Site" DIP switch **8** to the "OFF" position.
 - ⇒ Control on the device is deactivated.
- ⇒ The valve is in the open position.



15.1.2 Moving the valve to the closed position

1. Move the "ON-Site" DIP switch **8** to the "ON" position.
 - ⇒ Control on the device is activated.
 2. Press the "INIT/CLOSE" button **10**.
 - ⇒ The valve moves slowly to the closed position.
 3. Also press the "OPEN" button **9**.
 - ⇒ The valve moves quickly to the closed position.
 - ⇒ If the valve is fully closed, the high visibility LEDs are lit in orange.
 4. Move the "ON-Site" DIP switch **8** to the "OFF" position.
 - ⇒ Control on the device is deactivated.
- ⇒ The valve is in the closed position.

15.2 Operation via the web server

See separate "eSy-Web" operating instructions.

15.3 Manual override

 WARNING	
	<p>Rotating cover!</p> <ul style="list-style-type: none"> ▶ Risk of crushing. ● Disconnect the power supply before using the manual override.

1. Disconnect the power supply.
2. Turn housing cover **3** clockwise.
3. Remove housing cover **3**.

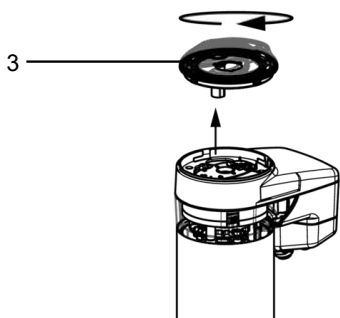

4. Place the actuator of housing cover **12** in the starting point for manual override.

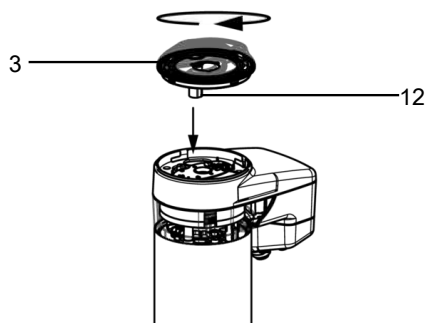

- ⇒ The product closes.
7. Pull manual override off the starting point.
8. Ensure correct positioning of the O-ring.
9. Push actuator **12** into the groove provided for this purpose.
10. Turn housing cover **3** anticlockwise until it stops.
- ⇒ The actuator cover is closed.
11. Reconnect the power supply.

Item	Name
3	Housing cover
12	Housing cover actuator

Groove for actuator

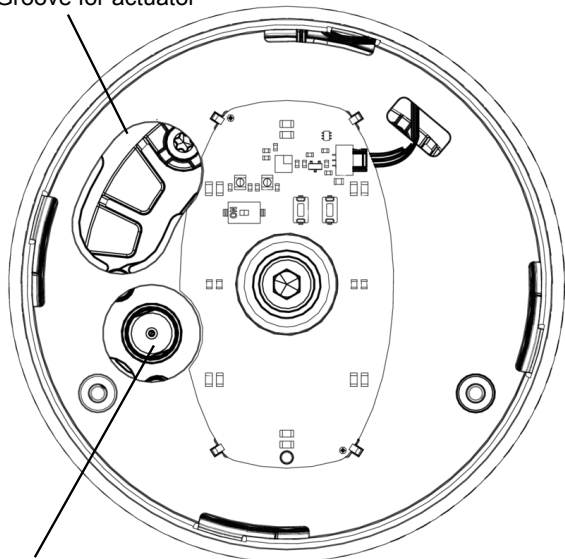

Starting point for manual override

5. Turn housing cover **3** anticlockwise.
- ⇒ The product opens.
6. Turn housing cover **3** clockwise.

16 Inspection and maintenance

⚠ WARNING

The equipment is subject to pressure!

- ▶ Risk of severe injury or death
- Depressurize the plant or plant component.
- Completely drain the plant or plant component.

⚠ CAUTION

Use of incorrect spare parts!

- ▶ Damage to the GEMÜ product
- ▶ Manufacturer liability and guarantee will be void.
- Use only genuine parts from GEMÜ.

⚠ CAUTION



Hot plant components!

- ▶ Risk of burns
- Only work on plant that has cooled down.

NOTICE

Exceptional maintenance work!

- ▶ Damage to the GEMÜ product
- Any maintenance work and repairs not described in these operating instructions must not be performed without consulting the manufacturer first.

The operator must carry out regular visual examination of the GEMÜ products dependent on the operating conditions and the potential danger in order to prevent leakage and damage. The product also must be disassembled and checked for wear in the corresponding intervals.

1. Have servicing and maintenance work performed by trained personnel.
2. Wear appropriate protective gear as specified in plant operator's guidelines.
3. Shut off plant or plant component.
4. Secure the plant or plant component against recommissioning.
5. Depressurize the plant or plant component.
6. Actuate GEMÜ products which are always in the same position four times a year.

16.1 Spare parts

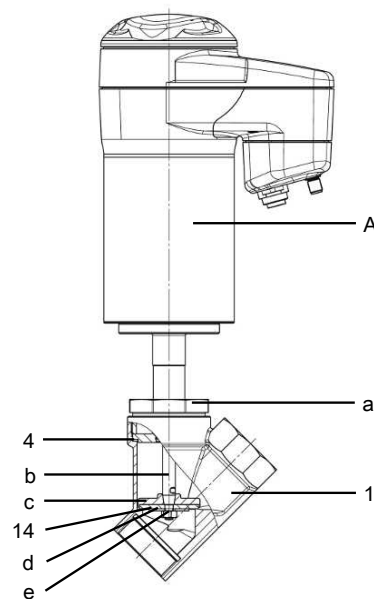

Fig. 9: Spare parts

Item	Name	Order description
1	Valve body	K514...
4	Sealing washer	549...SVS...
14	Seat seal	
A	Actuator	9549
a	Union nut	-
b	Spindle	-
c	Valve plug	-
d	Retaining washer	-
e	Nut	-

16.2 Removing the actuator

1. Move the actuator **A** to the open position.
2. Undo union nut **a**.
3. Lift actuator **A** off valve body **1**.
4. Clean all parts of contamination (do not damage parts during cleaning).
5. Check parts for potential damage, replace if necessary (only use genuine parts from GEMÜ).

16.3 Replacing the seals

1. Remove the actuator (see "Removing the actuator", page 40).
 2. Remove sealing washer **4** from the valve body.
 3. Loosen nut **e** on spindle **b** (hold spindle **b** with appropriate tool that will not damage the spindle surfaces).
 4. Clean all parts of contamination (do not damage parts during cleaning).
 5. Insert new seat seal **14**.
 6. Insert retaining washer **d**.
 7. Apply appropriate thread locking compound on the thread of spindle **b**.
 8. Fix spindle **b** in place with nut **e** (hold spindle **b** in place with appropriate tools which do not damage the spindle surfaces).
 9. Insert new sealing washer **4** in valve body **1**.
- Mount the actuator (see "Mounting the actuator", page 41).

16.4 Mounting the actuator

NOTICE

Important:

- ▶ Clean all parts of contamination (do not damage the parts during cleaning) following removal. Check parts for potential damage; replace if necessary (only use genuine parts from GEMÜ).

CAUTION



Incorrect combination of actuator and valve body!

- ▶ Risk of damage to the actuator and valve body
- For control valves with a reduced valve seat, make sure that the combination of actuator and valve body is correct.
- Compare the product label of the actuator with the valve body marking.

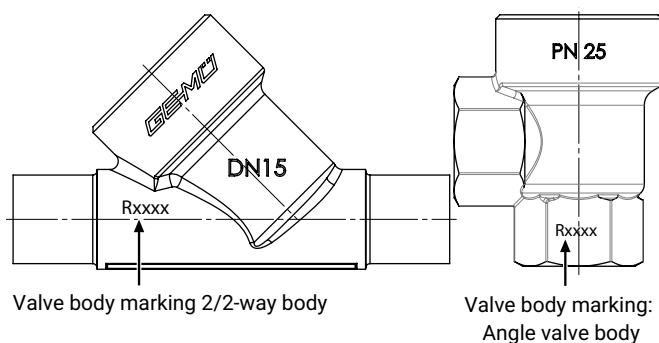

Actuator product label	Valve body marking
RAxxx	R002
RBxxx	R004
RCxxx	R006
RDxxx	R008
RExxx	R010
RFxxx	R012
RGxxx	R015
RHxxx	R020
RJxxx	R025
RKxxx	R032
RMxxx	R040

1. Move the actuator **A** to the open position.
2. Lubricate the thread of the union nut **a** using a suitable lubricant.
3. Place actuator **A** on valve body **1** approx. 90° in front of the end position (orientation of the connections) and screw hand tight with union nut **a**.
4. Tighten union nut **a** with an open-end wrench (for torques, see table).
 - ⇒ This rotates the actuator clockwise approx. 90° to the desired position.

Nominal size	Torque
DN 10	90 Nm
DN 15	90 Nm
DN 20	100 Nm
DN 25	120 Nm
DN 32	120 Nm
DN 40	150 Nm
DN 50	200 Nm
DN 65	260 Nm
DN 80	280 Nm

5. Move the actuator **A** to the closed position.
6. With the valve fully assembled, check the function and tightness.

17 Troubleshooting

Error	Possible cause	Troubleshooting
The product is leaking downstream (does not close or does not close fully)	Operating pressure too high	Operate the product with operating pressure specified in datasheet
The product is leaking in the passage (does not close or does not close completely).	Valve body leaking or damaged	Carry out initialisation, check valve body for damage, replace valve body if necessary.
The product does not close or does not close fully	The actuator design is not suitable for the operating conditions	Use an actuator that is designed for the operating conditions
	Foreign matter in the product	Remove and clean the product
	Voltage is not connected	Connect voltage
The product does not open or does not open fully	Actuator defective	Replace the actuator
	Operating pressure too high	Operate the product with operating pressure specified in datasheet
	Foreign matter in the product	Remove and clean the product
	The actuator design is not suitable for the operating conditions	Use an actuator that is designed for the operating conditions
	Voltage is not connected	Connect voltage
	Cable ends incorrectly wired	Wire cable ends correctly
The product is leaking between actuator and valve body	Bolting between valve body and actuator loose	Tighten bolting between valve body and actuator
	Actuator/valve body damaged	Replace actuator/valve body
The product is leaking between actuator flange and valve body	Mounting parts loose	Retighten mounting parts
	Valve body / actuator damaged	Replace valve body/actuator
Valve body of the GEMÜ product is leaking	Valve body of the GEMÜ product is faulty or corroded	Check valve body of the GEMÜ product for potential damage, replace valve body if necessary
Body of the GEMÜ product is leaking	Incorrect installation	Check installation of valve body in piping
Valve body connection to piping leaking	Incorrect installation	Check installation of valve body in piping
LED 1 is not lit	No initialisation	Initialise valve
	Supply voltage too low	Check supply voltage
LED 1 lights up yellow	Set value signal outside of the area	Check set value signal
	Temperature error	Check temperature
LED 1 flashes yellow	Actual value signal outside of the area	Check actual value signal
LED 1 and 2 are flashing yellow and red simultaneously	No calibration	Contact GEMÜ
	Internal error	Contact GEMÜ

18 Removal from piping

1. Remove in reverse order to installation.
2. Unscrew the electrical wiring.
3. Disassemble the product. Observe warning notes and safety information.

19 Disposal

1. Pay attention to adhered residual material and gas diffusion from penetrated media.
2. Dispose of all parts in accordance with the disposal regulations/environmental protection laws.

20 Returns

Legal regulations for the protection of the environment and personnel require that the completed and signed return delivery note is included with the dispatch documents. Returned goods can be processed only when this note is completed. If no return delivery note is included with the product, GEMÜ cannot process credits or repair work but will dispose of the goods at the operator's expense.

1. Clean the product.
2. Request a return delivery note from GEMÜ.
3. Complete the return delivery note.
4. Send the product with a completed return delivery note to GEMÜ.

21 EU Declaration of Incorporation according to the EC Machinery Directive 2006/42/EC, Annex II B



EU Declaration of Incorporation

according to the EC Machinery Directive 2006/42/EC, Annex II B

We, the company GEMÜ Gebr. Müller Apparatebau GmbH & Co. KG
Fritz-Müller-Strasse 6-8
74653 Ingelfingen-Criesbach, Germany

hereby declare under our sole responsibility that the below-mentioned product complies with the relevant essential health and safety requirements in accordance with Annex I of the above-mentioned Directive.

Product: GEMÜ 549
Product name: Motorized angle seat globe valve
The following essential health and safety requirements of the EC Machinery Directive 2006/42/EC, Annex I have been applied or adhered to: 1.1.2.; 1.1.3.; 1.1.5.; 1.3.2.; 1.3.4.; 1.3.7.; 1.3.8.; 1.5.1.; 1.5.13.; 1.5.2.; 1.5.4.; 1.5.6.; 1.5.7.; 1.5.8.; 1.6.1.; 1.6.3.; 1.6.5.; 1.7.1.; 1.7.1.1.; 1.7.2.; 1.7.3.; 1.7.4.; 1.7.4.1.; 1.7.4.2.; 1.7.4.3.
The following harmonized standards (or parts thereof) have been applied: EN ISO 12100:2010

We also declare that the specific technical documents have been created in accordance with part B of Annex VII.

The manufacturer undertakes to transmit relevant technical documents on the partly completed machinery to the national authorities in response to a reasoned request. This communication takes place electronically.

This does not affect the industrial property rights.

The partly completed machinery may be commissioned only if it has been determined, if necessary, that the machinery into which the partly completed machinery is to be installed meets the provisions of the Machinery Directive 2006/42/EC.

M. Barghoorn
Head of Global Technics
Ingelfingen, 17/07/2023

22 EU Declaration of Conformity in accordance with 2014/68/EU (Pressure Equipment Directive)



EU Declaration of Conformity

in accordance with 2014/68/EU (Pressure Equipment Directive)

We, the company GEMÜ Gebr. Müller Apparatebau GmbH & Co. KG
Fritz-Müller-Strasse 6-8
74653 Ingelfingen-Criesbach, Germany

hereby declare under our sole responsibility that the below-mentioned product complies with the regulations of the above-mentioned Directive.

Product: GEMÜ 549
Product name: Motorized angle seat globe valve
Notified body: TÜV Rheinland Industrie Service GmbH
Am Grauen Stein 1
51105 Cologne, Germany

ID number of the notified body: 0035
No. of the QA certificate: 01 202 926/Q-02 0036

Applied conformity assessment procedure(s): Module H

The following harmonized standards (or parts thereof) have been applied: EN 12516-3:2002/AC:2003

Information for products with a nominal size \leq DN 25:

The products are developed and produced according to GEMÜ's in-house process instructions and standards of quality which comply with the requirements of ISO 9001 and ISO 14001. According to Article 4, Paragraph 3 of the Pressure Equipment Directive 2014/68/EU, these products must not be identified by a CE-marking.

Other applied technical standards / Remarks:

- AD 2000

M. Barghoorn
Head of Global Technics

Ingelfingen, 17/07/2023

23 EU Declaration of Conformity in accordance with 2014/30/EU (EMC Directive)



EU Declaration of Conformity
in accordance with 2014/30/EU (EMC Directive)

We, the company GEMÜ Gebr. Müller Apparatebau GmbH & Co. KG
Fritz-Müller-Strasse 6-8
74653 Ingelfingen-Criesbach, Germany

hereby declare under our sole responsibility that the below-mentioned product complies with the regulations of the above-mentioned Directive.

Product: GEMÜ 549
Product name: Motorized angle seat globe valve
The following harmonized standards (or parts thereof) have been applied: EN 61800-3:2004/A1:2012; EN 61000-6-2:2005/AC:2005 (valid for all types)
EN 61326-1:2013; EN 61000-6-4:2007/A1:2011 (only valid for Actuator size 1 / Actuator size 0)

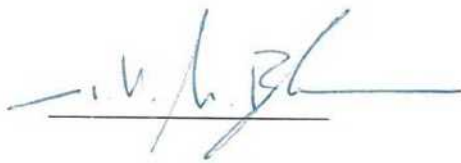

M. Barghoorn
Head of Global Technics
Ingelfingen, 17/07/2023

24 EU Declaration of Conformity In accordance with 2011/65/EU (RoHS Directive)



EU Declaration of Conformity
In accordance with 2011/65/EU (RoHS Directive)

We, the company GEMÜ Gebr. Müller Apparatebau GmbH & Co. KG
Fritz-Müller-Strasse 6-8
74653 Ingelfingen-Criesbach, Germany

hereby declare under our sole responsibility that the below-mentioned product complies with the regulations of the above-mentioned Directive.

Product: GEMÜ 549
Product name: Motorized angle seat globe valve
The following harmonized standards (or parts thereof) have been applied: EN IEC 63000:2018

A handwritten signature in blue ink, appearing to read "M. Barghoorn", written over a horizontal line.

M. Barghoorn
Head of Global Technics
Ingelfingen, 17/07/2023



GEMÜ Gebr. Müller Apparatebau GmbH & Co. KG
Fritz-Müller-Straße 6-8, 74653 Ingelfingen-Criesbach, Germany
Phone +49 (0) 7940 1230 · info@gemue.de
www.gemu-group.com

Subject to alteration

04.2024 | 88614476