

GEMÜ 649 eSyDrive

Motorized diaphragm valve

EN

Operating instructions



All rights including copyrights or industrial property rights are expressly reserved.

Keep the document for future reference.

© GEMÜ Gebr. Müller Apparatebau GmbH & Co. KG
27.05.2024

Contents

1	General information	4			
1.1	Information	4			
1.2	Symbols used	4			
1.3	LED symbols	4			
1.4	Definition of terms	4			
1.5	Warning notes	4			
2	Safety information	5			
3	Product description	5			
3.1	Construction	5			
3.2	Description	7			
3.3	Function	7			
3.4	Product label	7			
5	GEMÜ CONEXO	8			
6	Reading out the RFID chip	9			
7	Order data	10			
7.1	Order codes	10			
7.2	Order example	12			
8	Technical data	13			
8.1	Medium	13			
8.2	Temperature	13			
8.3	Pressure	14			
8.4	Product conformity	15			
8.5	Mechanical data	16			
8.6	Actuator duty cycle and service life	17			
8.7	Electrical data	17			
9	Electrical connection	20			
10	Dimensions	23			
10.1	Actuator dimensions	23			
10.2	Body dimensions	24			
11	Delivery	38			
12	Transport	38			
13	Storage	38			
14	Installation in piping	38			
14.1	Preparing for installation	38			
14.2	Installation position	39			
14.3	Installation with clamp connections	39			
14.4	Installation with butt weld spigots	39			
14.5	Installation with threaded sockets	39			
14.6	Installation with threaded spigots	40			
14.7	Installation with flanged connection	40			
15	Network connection	40			
15.1	Network settings	40			
15.2	Connecting the network	40			
15.3	Resetting the network settings	40			
16	Commissioning	41			
16.1	Commissioning on the device	41			
16.2	Commissioning via the eSy-Web web interface	41			
16.3	Commissioning via digital input	41			
17	Operation	41			
17.1	Operation on the device	41			
17.2	Operation via the web server	41			
17.3	Manual override	41			
18	Inspection and maintenance	42			
18.1	Spare parts	42			
			18.2	Removing the actuator	43
			18.3	Removing the diaphragm	43
			18.4	Mounting the compressor	43
			18.5	Mounting the diaphragm	43
			18.6	Mounting the actuator	44
			19	Error messages	45
			19.1	LED error messages	45
			19.2	Troubleshooting	46
			20	Disposal	48
			21	Returns	48
			22	EU Declaration of Incorporation according to the EC Machinery Directive 2006/42/EC, Annex II B ...	49
			23	EU Declaration of Conformity in accordance with 2014/30/EU (EMC Directive)	50
			24	EU Declaration of Conformity in accordance with 2014/68/EU (Pressure Equipment Directive)	51
			25	EU Declaration of Conformity In accordance with 2011/65/EU (RoHS Directive)	52

1 General information

1.1 Information

- The descriptions and instructions apply to the standard versions. For special versions not described in this document the basic information contained herein applies in combination with any additional special documentation.
- Correct installation, operation, maintenance and repair work ensure faultless operation of the product.
- Should there be any doubts or misunderstandings, the German version is the authoritative document.
- Contact us at the address on the last page for staff training information.

1.2 Symbols used

The following symbols are used in this document:

Symbol	Meaning
●	Tasks to be performed
▶	Response(s) to tasks
-	Lists

1.3 LED symbols

The following LED symbols are used in the documentation:

Symbol	LED conditions
○	Off
●	Lit (on)
☼	Flashing

1.4 Definition of terms

Working medium

The medium that flows through the GEMÜ product.

Diaphragm size

Uniform seat size of GEMÜ diaphragm valves for different nominal sizes.

1.5 Warning notes

Wherever possible, warning notes are organised according to the following scheme:

SIGNAL WORD	
Possible symbol for the specific danger	<p>Type and source of the danger</p> <ul style="list-style-type: none"> ▶ Possible consequences of non-observance. ● Measures for avoiding danger.

Warning notes are always marked with a signal word and sometimes also with a symbol for the specific danger.

The following signal words and danger levels are used:





⚠ DANGER	
	<p>Imminent danger!</p> <ul style="list-style-type: none"> ▶ Non-observance can cause death or severe injury.

⚠ WARNING	
	<p>Potentially dangerous situation!</p> <ul style="list-style-type: none"> ▶ Non-observance can cause death or severe injury.

⚠ CAUTION	
	<p>Potentially dangerous situation!</p> <ul style="list-style-type: none"> ▶ Non-observance can cause moderate to light injury.

NOTICE	
	<p>Potentially dangerous situation!</p> <ul style="list-style-type: none"> ▶ Non-observance can cause damage to property.

The following symbols for the specific dangers can be used within a warning note:

Symbol	Meaning
	Danger of explosion!
	Corrosive chemicals!
	Hot plant components!
	Rotating cover!

2 Safety information

The safety information in this document refers only to an individual product. Potentially dangerous conditions can arise in combination with other plant components, which need to be considered on the basis of a risk analysis. The operator is responsible for the production of the risk analysis and for compliance with the resulting precautionary measures and regional safety regulations.

The document contains fundamental safety information that must be observed during commissioning, operation and maintenance. Non-compliance with these instructions may cause:

- Personal hazard due to electrical, mechanical and chemical effects.
- Hazard to nearby equipment.
- Failure of important functions.
- Hazard to the environment due to the leakage of dangerous substances.

The safety information does not take into account:

- Unexpected incidents and events, which may occur during installation, operation and maintenance.
- Local safety regulations which must be adhered to by the operator and by any additional installation personnel.

Prior to commissioning:

1. Transport and store the product correctly.
2. Do not paint the bolts and plastic parts of the product.
3. Carry out installation and commissioning using trained personnel.
4. Provide adequate training for installation and operating personnel.
5. Ensure that the contents of the document have been fully understood by the responsible personnel.
6. Define the areas of responsibility.
7. Observe the safety data sheets.
8. Observe the safety regulations for the media used.

During operation:

9. Keep this document available at the place of use.
10. Observe the safety information.
11. Operate the product in accordance with this document.
12. Operate the product in accordance with the specifications.
13. Maintain the product correctly.
14. Do not carry out any maintenance work and repairs not described in this document without consulting the manufacturer first.

In cases of uncertainty:

15. Consult the nearest GEMÜ sales office.

3 Product description

3.1 Construction

3.1.1 Construction

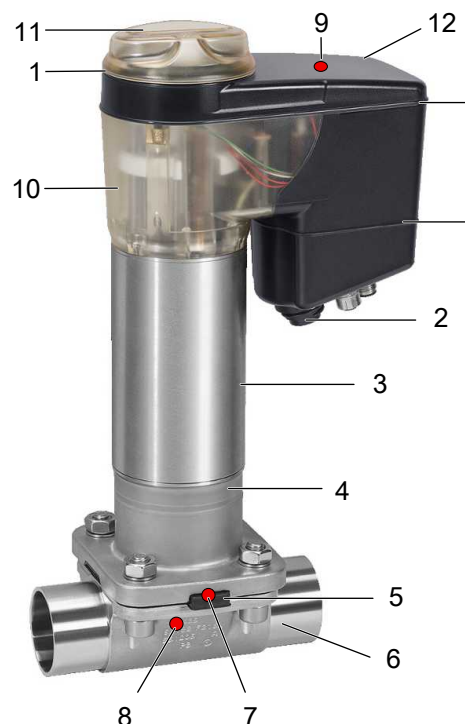

Item	Name	Materials
1	O-rings	EPDM
2	Electrical connections	
3	Actuator base	1.4301/1.4305
4	Distance piece with leak detection hole	1.4408
5	Diaphragm	CR, EPDM, FKM, NBR, PTFE/EPDM
6	Valve bodies	EN-GJS-400-18-LT (GGG 40.3) EN-GJS-400-18-LT (GGG 40.3), PFA lined EN-GJS-400-18-LT (GGG 40.3), PP lined EN-GJS-400-18-LT (GGG 40.3), hard rubber lined 1.4408, investment casting 1.4408, PFA lined 1.4435 (F316L), forged body 1.4435 (BN2), forged body, Δ Fe < 0.5% 1.4435, investment casting 1.4539, forged body CW614N, CW617N (brass)
7	CONEXO diaphragm RFID chip (see Conexo information)	

Item	Name	Materials
8	CONEXO body RFID chip (see Conexo information)	
9	CONEXO actuator RFID chip (see Conexo information)	
10	Optical position indicator	PESU (AG0, AG2) PC (AG1)
11	Cover with high visibility LED, manual override and on-site control	PESU (AG0, AG2) PC (AG1)
12	Actuator top	PESU black (AG0, AG2) PC black (AG1)

3.1.2 Buttons for on-site control

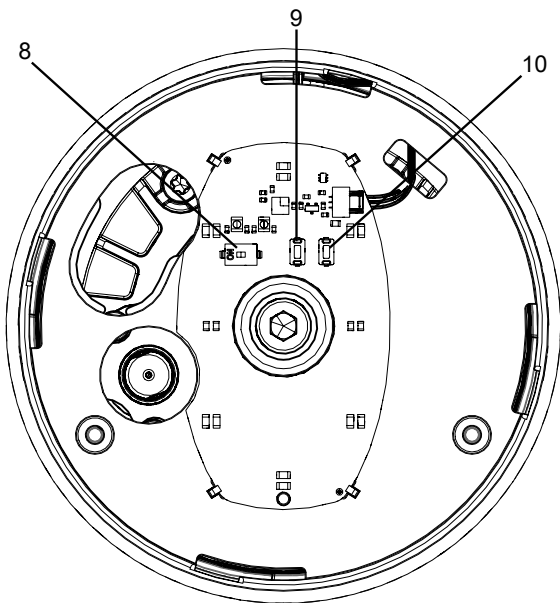

Fig. 1: Position of the buttons

Item	Name	Function
8	DIP switch, "ON-site" control	Switches the on-site control on the device on or off
9	"OPEN" button	Moves actuator to the open position Resets the network settings
10	"INIT/CLOSE" button	Moves actuator to the closed position Starting initialisation

3.1.3 LED displays

3.1.3.1 On-site status LEDs

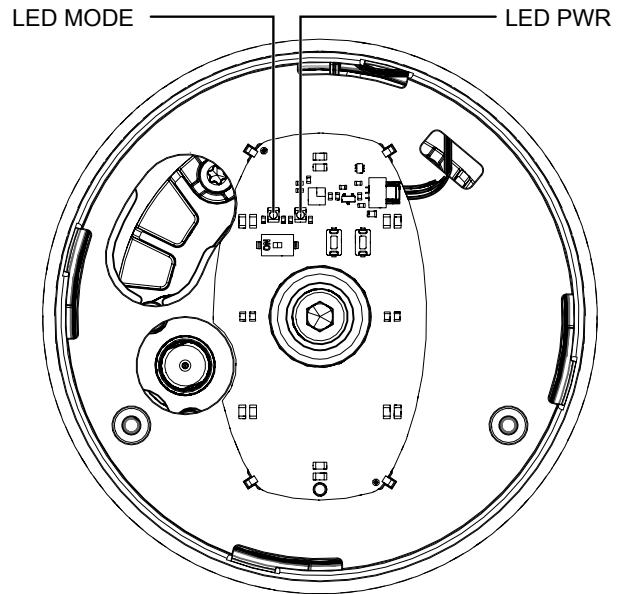



Fig. 2: Position of the status LEDs

The user checks the following conditions directly on-site at the valve using LED MODE and LED PWR:

Function	LED MODE		LED PWR	
	Yellow	Blue	Green	Red
Automatic operation	●	○	●	○
Manual operation	☀	○	●	○
Actuator switched off (OFF mode)	○	○	●	○
Manual operation (on-site)	○	●	●	○
Software update	☀	☀	●	○
	alternating			
On-site initialisation (buttons)	○	☀	●	○
Remote initialisation (via Di-gIn)	●	○	●	○

Function	LED MODE		LED PWR	
	Yellow	Blue	Green	Red
Operation via emergency power supply module				

3.1.3.2 High visibility LEDs

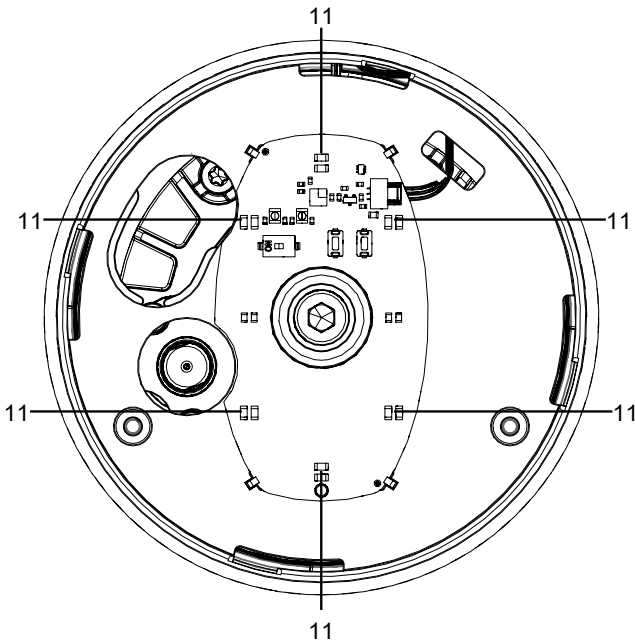
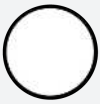



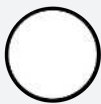
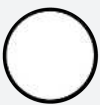

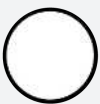
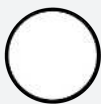

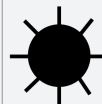

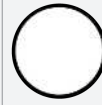

Fig. 3: Position of the high visibility LEDs

Item	Name
11	High visibility LEDs

Function		High visibility LED	
		green	orange
OPEN position	Position indicator LEDs standard		
OPEN position	Position indicator LEDs inversed		
CLOSED position	Position indicator LEDs standard		
CLOSED position	Position indicator LEDs inversed		
Position unknown	(e.g. 50%)		

Function	High visibility LED	
	green	orange
Initialization		
	alternating	
Location function		

3.2 Description

The GEMÜ 649 eSyDrive diaphragm valve is actuated by a motorized hollow shaft actuator. It is based on technology that does not use brushes or sensors and therefore guarantees high performance and a long service life. In addition to Open/Close applications, the valve is ideal for variable and complex control applications. The actuator has an integrated web server for parameterization and diagnostics purposes.

3.3 Function

The product controls or regulates (depending on version) a flowing medium by being closed or opened by a motorized actuator.

The product has an optical position indicator as standard. The optical position indicator indicates the OPEN and CLOSED positions.

3.4 Product label

The product label is located on the actuator. Product label data (example):

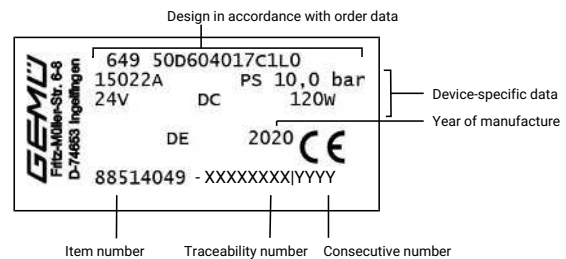

The month of manufacture is encoded in the traceability number and can be obtained from GEMÜ. The product was manufactured in Germany.

The operating pressure stated on the product label applies to a media temperature of 20 °C. The product can be used up to the maximum stated media temperature. You can find the pressure/temperature correlation in the technical data.

4 Correct use

⚠ DANGER



Danger of explosion!

- ▶ Risk of death or severe injury
- Do **not** use the product in potentially explosive zones.

⚠ WARNING

Improper use of the product!

- ▶ Risk of severe injury or death
- ▶ Manufacturer liability and guarantee will be void.
- Only use the product in accordance with the operating conditions specified in the contract documentation and in this document.

The product is designed for installation in piping systems and for controlling a working medium.

The product is not intended for use in potentially explosive areas.

- Use the product in accordance with the technical data.

5 GEMÜ CONEXO

Order without CONEXO

If you have ordered the product without CONEXO functionality, the RFID chip is used for traceability in the production process and quality assurance. Expansion to include the CONEXO functionality at a later date must be coordinated with GEMÜ.

Order with CONEXO

GEMÜ CONEXO must be ordered separately with the ordering option "CONEXO" (see order data).

For electronic identification purposes, each replaceable component contained in the product you have purchased is equipped with an RFID chip (1). Where you can find the RFID chip differs from product to product.

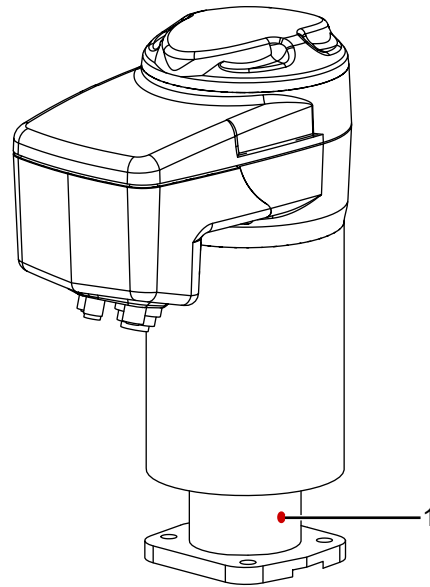

Fig. 4: Actuator RFID chip

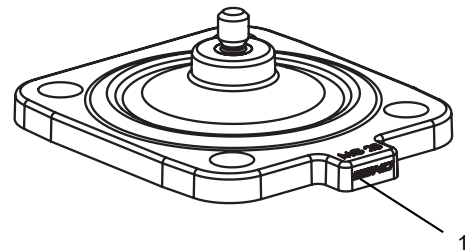

Fig. 5: Diaphragm RFID chip

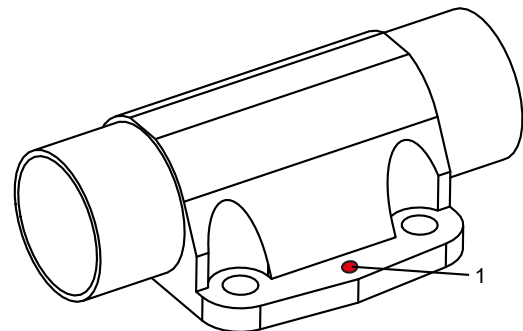
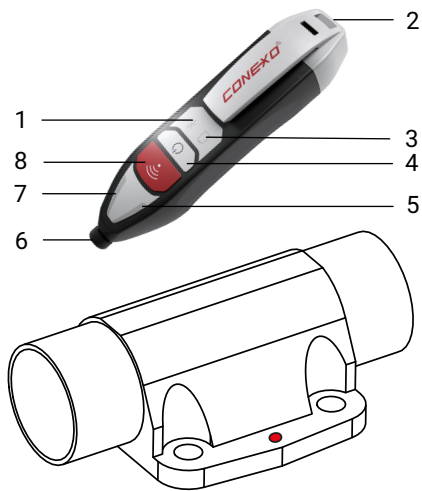

Fig. 6: Valve body RFID chip

The CONEXO pen helps read out information stored in these RFID chips. The CONEXO app or CONEXO portal is required to view this information.

6 Reading out the RFID chip



1. Press the On/Off key **4** on the CONEXO pen.
 - ⇒ The CONEXO pen has been switched on.
 - ⇒ LED **1** flashes.
2. Connect the CONEXO pen to the tablet.
 - ✓ The user finds themselves in a menu within the CONEXO app where a scanning operation is requested.
3. Hold the CONEXO pen directly against the RFID chip of a component or functional location and press the scan key **8**.
 - ⇒ If an RFID chip has been scanned correctly, the LED **7** turns green.
 - ⇒ If an RFID chip has not been scanned correctly, the LED **5** turns red.
 - ⇒ An audible signal is emitted during a correct scan process.
 - ⇒ The data that is read out is transferred to the CONEXO app.
4. Scan as many components as required.
5. Hold down the On/Off key **4** for at least three seconds.
 - ⇒ The CONEXO pen has been switched off.

7 Order data

The order data provide an overview of standard configurations.

Please check the availability before ordering. Other configurations available on request.

Order codes

1 Type	Code
Diaphragm valve, electrically operated, electro-mechanical hollow shaft actuator, eSyDrive	649

2 DN	Code
DN 4	4
DN 6	6
DN 8	8
DN 10	10
DN 12	12
DN 15	15
DN 20	20
DN 25	25
DN 32	32
DN 40	40
DN 50	50
DN 65	65

3 Body configuration	Code
Tank bottom valve body	B
Body configuration code B: Dimensions and designs on request	
2/2-way body	D
T-body	T
Body configuration code T: Dimensions on request	

4 Connection type	Code
Spigot	
Spigot DIN	0
Spigot DIN EN 10357 series B (2014 edition; formerly DIN 11850 series 1)	16
Spigot EN 10357 series A/DIN 11866 series A formerly DIN 11850 series 2	17
Spigot DIN 11850 series 3	18
Spigot JIS-G 3447	35
Spigot JIS-G 3459 schedule 10s	36
Spigot SMS 3008	37
Spigot BS 4825, part 1	55
Spigot ASME BPE/DIN EN 10357 series C (from 2022 edition)/DIN 11866 series C	59
Spigot ISO 1127/DIN EN 10357 series C (2014 edition)/DIN 11866 series B	60
Spigot ANSI/ASME B36.19M schedule 10s	63
Spigot ANSI/ASME B36.19M schedule 5s	64
Spigot ANSI/ASME B36.19M schedule 40s	65
Threaded connection	
Threaded socket DIN ISO 228	1
NPT female thread	31
Threaded spigot DIN 11851	6

4 Connection type	Code
Cone spigot and union nut DIN 11851	6K
Flange	
Flange EN 1092, PN 16, form B, face-to-face dimension FTF EN 558 series 1, ISO 5752, basic series 1, length only for body configuration D	8
Flange JIS B2220, 10K, RF, face-to-face dimension FTF EN 558 series 1, ISO 5752, basic series 1, length only for body configuration D	34
Flange ANSI Class 150 RF, face-to-face dimension FTF MSS SP-88, length only for body configuration D	38
Flange ANSI Class 125/150 RF, face-to-face dimension FTF EN 558 series 1, ISO 5752, basic series 1, length only for body configuration D	39
Clamp	
Clamp ASME BPE, face-to-face dimension FTF ASME BPE, length only for body configuration D	80
Clamp DIN 32676 series B, face-to-face dimension FTF EN 558 series 7, length only for body configuration D	82
Clamp ASME BPE, for pipe ASME BPE, face-to-face dimension FTF EN 558 series 7, length only for body configuration D	88
Clamp DIN 32676 series A, face-to-face dimension FTF acc. to EN 558 series 7, length only for body configuration D	8A
Clamp ISO 2852 for pipe ISO 2037, clamp SMS 3017 for pipe SMS 3008 face-to-face dimension FTF EN 558 series 7, length only for body configuration D	8E
Clamp DIN 32676 series C, face-to-face dimension FTF ASME BPE, length only for body configuration D	8P
Clamp DIN 32676 series C, face-to-face dimension FTF EN 558 series 7, length only for body configuration D	8T

5 Valve body material	Code
SG iron material	
EN-GJS-400-18-LT (GGG 40.3), PFA lined	17
EN-GJS-400-18-LT (GGG 40.3), PP lined	18
EN-GJS-400-18-LT (GGG 40.3), hard rubber lined	83
EN-GJS-400-18-LT (GGG 40.3)	90
Investment casting material	
1.4408, investment casting	37

5 Valve body material	Code
1.4408, PFA lined	39
1.4435, investment casting	C3
Forged material	
1.4435 (F316L), forged body	40
1.4435 (BN2), forged body, Δ Fe < 0.5%	42
1.4539, forged body	F4
Brass	
CW614N, CW617N (brass)	12

6 Diaphragm material	Code
Elastomer	
NBR	2
FKM	4
CR	8
EPDM	13
EPDM	17
EPDM	19
EPDM	28
EPDM	29
PTFE	
PTFE/EPDM one-piece	54
PTFE/EPDM two-piece	5M
PTFE/FKM two-piece	5T
PTFE/PVDF/EPDM three-piece	71
Note: The PTFE/EPDM diaphragm (code 5M, code 5T, code 71) is available from diaphragm size 25.	

7 Voltage/Frequency	Code
24 V DC	C1

8 Control module	Code
OPEN/CLOSE, positioner and process controller	L0

9 Surface	Code
Ra \leq 6.3 μ m (250 μ in.) for media wetted surfaces, mechanically polished internal	1500
Ra \leq 0.8 μ m (30 μ in.) for media wetted surfaces, in accordance with DIN 11866 H3, mechanically polished internal	1502
Ra \leq 0.8 μ m (30 μ in.) for media wetted surfaces, in accordance with DIN 11866 HE3, electropolished internal/external	1503
Ra \leq 0.6 μ m (25 μ in.) for media wetted surfaces, mechanically polished internal	1507
Ra \leq 0.6 μ m (25 μ in.) for media wetted surfaces, electropolished internal/external	1508
Ra \leq 0.4 μ m (15 μ in.) for media wetted surfaces, in accordance with DIN 11866 H4, mechanically polished internal	1536
Ra \leq 0.4 μ m (15 μ in.) for media wetted surfaces, in accordance with DIN 11866 HE4, electropolished internal/external	1537
Ra \leq 0.25 μ m (10 μ in.) for media wetted surfaces *), in accordance with DIN 11866 HE5, electropolished internal/external, *) for inner pipe diameters < 6 mm, in the spigot Ra \leq 0.38 μ m	1516

9 Surface	Code
Ra \leq 0.25 μ m (10 μ in.) for media wetted surfaces *), in accordance with DIN 11866 H5, mechanically polished internal, *) for inner pipe diameters < 6 mm, in the spigot Ra \leq 0.38 μ m	1527
Ra max. 0.51 μ m (20 μ in.) for media wetted surfaces, in accordance with ASME BPE SF1, mechanically polished internal	SF1
Ra max. 0.64 μ m (25 μ in.) for media wetted surfaces, in accordance with ASME BPE SF2, mechanically polished internal	SF2
Ra max. 0.76 μ m (30 μ in.) for media wetted surfaces, in accordance with ASME BPE SF3, mechanically polished internal	SF3
Ra max. 0.38 μ m (15 μ in.) for media wetted surfaces, in accordance with ASME BPE SF4, electropolished internal/external	SF4
Ra max. 0.51 μ m (20 μ in.) for media wetted surfaces, in accordance with ASME BPE SF5, electropolished internal/external	SF5
Ra max. 0.64 μ m (25 μ in.) for media wetted surfaces, in accordance with ASME BPE SF6, electropolished internal/external	SF6

10 Actuator version	Code
DN 4 - 15, diaphragm size 8	
Actuator size 0 diaphragm size 8	0B
DN 10-20, diaphragm size 10	
Actuator size 0	0A
DN 15 - 25, diaphragm size 25	
Actuator size 1	1A
DN 32 - 40, diaphragm size 40	
Actuator size 1	1A
Actuator size 2	2A
DN 50-65, diaphragm size 50	
Actuator size 2	2A

11 Special version	Code
Without	
BELGAQUA certification	B
Special version for oxygen, maximum medium temperature: 60 °C	S

12 CONEXO	Code
Without	
Integrated RFID chip for electronic identification and traceability	C

Order example

Ordering option	Code	Description
1 Type	649	Diaphragm valve, electrically operated, electro-mechanical hollow shaft actuator, eSyDrive
2 DN	50	DN 50
3 Body configuration	D	2/2-way body
4 Connection type	60	Spigot ISO 1127/DIN EN 10357 series C (2014 edition)/DIN 11866 series B
5 Valve body material	40	1.4435 (F316L), forged body
6 Diaphragm material	5M	PTFE/EPDM two-piece
7 Voltage/Frequency	C1	24 V DC
8 Control module	L0	OPEN/CLOSE, positioner and process controller
9 Surface	1503	Ra ≤ 0.8 µm (30 µin.) for media wetted surfaces, in accordance with DIN 11866 HE3, electropolished internal/external
10 Actuator version	2A	Actuator size 2
11 Special version	S	Special version for oxygen, maximum medium temperature: 60 °C
12 CONEXO		Without

8 Technical data

8.1 Medium

Working medium: Corrosive, inert, gaseous and liquid media which have no negative impact on the physical and chemical properties of the body and diaphragm material.
For special oxygen version (code S): only gaseous oxygen

8.2 Temperature

Media temperature:

Diaphragm material	Standard	Special version for oxygen
NBR (code 2)	-10 – 100 °C	-
FKM (code 4)	-10 – 90 °C	-
CR (code 8)	-10 – 100 °C	-
EPDM (code 13)	-10 – 100 °C	0 – 60 °C
EPDM (code 17)	-10 – 100 °C	-
EPDM (code 19)	-10 – 100 °C	0 – 60 °C
EPDM (code 28)	-10 – 85 °C	-
EPDM (code 29)	-10 – 100 °C	-
PTFE/EPDM (code 54)	-10 – 100 °C	0 – 60 °C
PTFE/EPDM (code 5M)	-10 – 100 °C	0 – 60 °C

Sterilization temperature:

EPDM (code 13)	max. 150 °C, max. 60 min per cycle
EPDM (code 17)	max. 150 °C, max. 180 min per cycle
EPDM (code 19)	max. 150 °C, max. 180 min per cycle
PTFE/EPDM (code 54)	max. 150 °C, constant temperature per cycle
PTFE/EPDM (code 5M)	max. 150 °C, constant temperature per cycle

The sterilization temperature is only valid for steam (saturated steam) or superheated water.

If the sterilization temperatures listed above are applied to the EPDM diaphragms for longer periods of time, the service life of the diaphragms will be reduced. In these cases, maintenance cycles must be adapted accordingly.

PTFE diaphragms can also be used as steam barriers; however, this will reduce their service life. This also applies to PTFE diaphragms exposed to high temperature fluctuations. The maintenance cycles must be adapted accordingly. GEMÜ 555 and 505 globe valves are particularly suitable for use in the area of steam generation and distribution. The following valve arrangement for interfaces between steam pipes and process pipes has proven itself over time: A globe valve for shutting off steam pipes and a diaphragm valve as an interface to the process pipes.

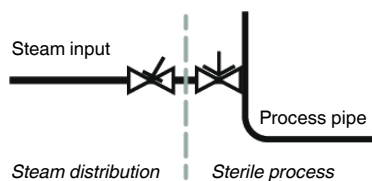

Ambient temperature: -10 – 60 °C

Storage temperature: 0 – 40 °C

8.3 Pressure

Operating pressure:

MG	DN	Actuator version	Diaphragm material		
			Elastomer	PTFE	
				Forged body	Cast body with and without lining
8	4 - 15	0B	0 - 10	0 - 10	0 - 6
10	10 - 20	0A	0 - 10	0 - 10	0 - 6
25	15 - 25	1A	0 - 10	0 - 10	0 - 6
40	32 - 40	1A	0 - 5	0 - 2	0 - 2
		2A	0 - 10	0 - 10	0 - 6
50	50 - 65	2A	0 - 10	0 - 10	0 - 6

MG = diaphragm size

All pressures are gauge pressures. Operating pressure values were determined with static operating pressure applied on one side of a closed valve. Sealing at the valve seat and atmospheric sealing is ensured for the given values.

Information on operating pressures applied on both sides and for high purity media on request.

Pressure rating:

PN 16

Leakage rate:

Leakage rate A to P11/P12 EN 12266-1

Cv values:

MG	DN	Connection type code								
		0	16	17	18	37	59	60	1	31
8	4	0.5	-	-	-	-	-	-	-	-
	6	-	-	1.1	-	-	-	1.2	-	-
	8	-	-	1.3	-	-	0.6	2.2	1.4	-
	10	-	2.1	2.1	2.1	-	1.3	-	-	-
	15	-	-	-	-	-	2.0	-	-	-
10	10	-	2.4	2.4	2.4	-	2.2	3.3	-	-
	12	-	-	-	-	-	-	-	3.2	-
	15	3.3	3.8	3.8	3.8	-	2.2	4.0	3.4	-
	20	-	-	-	-	-	3.8	-	-	-
25	15	4.1	4.7	4.7	4.7	-	-	7.4	6.5	6.5
	20	6.3	7.0	7.0	7.0	-	4.4	13.2	10.0	10.0
	25	13.9	15.0	15.0	15.0	12.6	12.2	16.2	14.0	14.0
40	32	25.3	27.0	27.0	27.0	26.2	-	30.0	26.0	26.0
	40	29.3	30.9	30.9	30.9	30.2	29.5	32.8	33.0	33.0
50	50	46.5	48.4	48.4	48.4	51.7	50.6	55.2	60.0	60.0
	65	-	-	-	-	62.2	61.8	-	-	-

MG = diaphragm size

Cv values in m³/h

Kv values determined in accordance with DIN EN 60534 standard, inlet pressure 5 bar, Δp 1 bar, stainless steel valve body and soft elastomer diaphragm. The Kv values for other product configurations (e.g. other diaphragm or body materials) may differ. In general, all diaphragms are subject to the influences of pressure, temperature, the process and their tightening torques. Therefore the Kv values may exceed the tolerance limits of the standard.

The Kv value curve (Kv value dependent on valve stroke) can vary depending on the diaphragm material and duration of use.

Cv values:

MG	DN	Cast body without lining		Rubber lining	Plastic lining
		Threaded body	Flanged body		
		Material code 90		Material code 83	Material code 17, 18, 39
25	15	8.0	10.0	5.0	6.0
	20	11.5	14.0	9.0	11.0
	25	11.5	17.0	13.0	15.0
40	32	28.0	36.0	23.0	29.0
	40	28.0	40.0	26.0	32.0
50	50	60.0	68.0	47.0	64.0
	65	-	68.0	47.0	64.0

MG = diaphragm size, Kv values in m³/h

Kv values determined in accordance with DIN EN 60534, inlet pressure 5 bar, Δp 1 bar, with connection flange EN 1092 length EN 558 series 1 (or threaded socket DIN ISO 228 for body material GGG40.3) and soft elastomer diaphragm. The Kv values for other product configurations (e.g. other diaphragm or body materials) may differ. In general, all diaphragms are subject to the influences of pressure, temperature, the process and their tightening torques. Therefore the Kv values may exceed the tolerance limits of the standard.

The Kv value curve (Kv value dependent on valve stroke) can vary depending on the diaphragm material and duration of use.

8.4 Product conformity

Machinery Directive: 2006/42/EC

Pressure Equipment Directive: 2014/68/EU

EMC Directive: 2014/30/EU

Food: Regulation (EC) No. 1935/2004*
Regulation (EC) No. 10/2011*
FDA*
USP* Class VI

Drinking water: Belgaqua*

RoHS Directive: 2011/65/EU

TA Luft (German Clean Air Act): The product meets the following requirements under the max. permissible operating conditions:
-Tightness or compliance with the specific leak rate within the sense of TA-Luft as well as VDI 2440 and VDI 2290
-Compliance with the requirements in accordance with DIN EN ISO 15848-1, Table C.2, Class BH
* depending on version and/or operating parameters

8.5 Mechanical data**Protection class:** IP 65 acc. to EN 60529

Actuating speed: Actuator version 0A, 0B adjustable, max. 6 mm/s
 Actuator version 1A adjustable, max. 6 mm/s
 Actuator version 2A adjustable, max. 4 mm/s

Flow direction: Optional

Installation position: Optional
 Observe the angle of rotation for optimized draining when it comes to installation.
 See separate document, "Angle of rotation technical information".

Weight: **Actuator**
 Actuator version 0A, 0B 2.1 kg
 Actuator version 1A 3.0 kg
 Actuator version 2A 9.0 kg

Body

Connection type Code		0, 16, 17, 18, 35, 36, 37, 55, 59, 60, 63, 64, 65	1	1	1, 31	31	6, 6K	8, 38, 39	80, 82, 88, 8A, 8E, 8P, 8T
Valve body		Spigot	Threaded socket				Threaded spigot	Flange	Clamp
Material code			12	37	90	37			
MG	DN								
8	4	0.09	-	-	-	-	-	-	-
	6	0.09	-	-	-	-	-	-	-
	8	0.09	-	0.09	-	-	-	-	0.15
	10	0.09	-	-	-	-	0.21	-	0.18
	15	0.09	-	-	-	-	-	-	0.18
10	10	0.30	-	-	-	-	0.33	-	0.30
	12	-	0.17	0.17	-	-	-	-	-
	15	0.30	0.26	0.26	-	-	0.35	-	0.43
	20	-	-	-	-	-	-	-	0.43
25	15	0.62	-	0.32	0.50	0.32	0.71	1.50	0.75
	20	0.58	-	0.34	0.60	0.34	0.78	2.20	0.71
	25	0.55	-	0.39	0.90	0.39	0.79	2.80	0.63
40	32	1.45	-	0.88	1.40	0.88	1.66	3.40	1.62
	40	1.32	-	0.93	1.90	0.93	1.62	4.50	1.50
50	50	2.25	-	1.56	2.70	1.56	2.70	6.30	2.50
	65	2.20	-	-	-	-	-	10.30	2.30

MG = diaphragm size, weight in kg

8.6 Actuator duty cycle and service life

Service life:	Control operation - Class C acc. to EN 15714-2 (1,800,000 start-ups and 1200 start-ups per hour). Open / Close duty - Minimum 1,000,000 switching cycles at room temperature and permissible duty cycle.
Duty cycle:	Control operation - Class C acc. to EN 15714-2. Open/Close duty - 100%

8.7 Electrical data

Supply voltage:	Actuator size 0	Actuator size 1	Actuator size 2
Voltage	U _v = 24 V DC ± 10%		
Rating	Max. 28 W	Max. 65 W	Max. 120 W
Reverse battery protection	Yes		

8.7.1 Analogue input signals

8.7.1.1 Set value

Input signal:	0/4 - 20 mA; 0 – 10 V DC (selectable using software)
Input type:	passive
Input resistance:	250 Ω
Accuracy/linearity:	≤ ±0.3% of full flow
Temperature drift:	≤ ±0.1% / 10°K
Resolution:	12 bit
Reverse battery protection:	No
Overload proof:	Yes (up to ± 24 V DC)

8.7.1.2 Process actual value

Input signal:	0/4 - 20 mA; 0 – 10 V DC (selectable using software)
Input type:	passive
Input resistance:	250 Ω
Accuracy/linearity:	≤ ±0.3% of full flow
Temperature drift:	≤ ±0.1% / 10°K
Resolution:	12 bit
Reverse battery protection:	No
Overload proof:	Yes (up to ± 24 V DC)

8.7.2 Digital input signals

Digital inputs:	3
Function:	Can be selected using software
Voltage:	24 V DC
Logic level "1":	>14 V DC
Logic level "0":	< 8 V DC
Input current:	typ. 2.5 mA (at 24 V DC)

8.7.3 Analogue output signals**8.7.3.1 Actual value**

Output signal:	0/4 - 20 mA; 0 – 10 V DC (selectable using software)
Output type:	Active (AD5412)
Accuracy:	≤ ±1% of full flow
Temperature drift:	≤ ±0.1% / 10°K
Load resistor:	≤ 750 kΩ
Resolution:	10 bit
Overload proof:	Yes (up to ± 24 V DC)
Short-circuit proof:	Yes

8.7.4 Digital output signals**8.7.4.1 Switching outputs 1 and 2**

Design:	2x make contact, potential-free
Switching voltage:	max. 48 V DC / 48 V AC
Switch rating:	max. 60 W / 2A
Switch points:	Adjustable 0 - 100 %

8.7.4.2 Switching output 3

Function:	Signal fault
Type of contact:	Push-Pull
Switching voltage:	Supply voltage
Switching current:	≤ 0.1 A
Drop voltage:	Max. 2.5 V DC at 0.1 A
Overload proof:	Yes (up to ± 24 V DC)
Short-circuit proof:	Yes
Pull-Down resistance:	120 kΩ

8.7.5 Communication eSy-Web

Interface:	Ethernet
Function:	Parameterisation via web browser
IP address:	192.168.2.1 alterable via web browser
Subnet screen:	255.255.252.0 alterable via web browser

The actuator and the PC must be in the same network to use the web server. The IP address of the actuator is entered in the web browser and the actuator can then be parametrised. In order to use more than one actuator, a definitive IP address must be assigned to each actuator in the same network.

8.7.6 Communication Modus TCP

Interface:	Modbus TCP
IP address:	192.168.2.1 alterable via web browser
Subnet screen:	255.255.252.0 alterable via web browser
Port:	502

Supported function codes:

Code Dezimal	Code Hex	Function
3	0x03	Read Holding Registers
4	0x04	Read Input Registers
6	0x06	Write Single Register
16	0x10	Write Multiple Registers
23	0x17	Read / Write Multiple Registers

8.7.7 Behaviour in the event of an error

Function:	In the event of an error the valve moves to the error position. Notes: Moving to the error position is only possible with full power supply. This behaviour is not a safety position. The valve must be operated with a GEMÜ 1571 emergency power supply module (see accessories) to ensure the function in case of voltage loss.
Error position:	Closed, open or hold (adjustable via eSy-web web interface).

9 Electrical connection

NOTICE

Appropriate cable socket / appropriate mating connector!

- ▶ The appropriate cable socket and/or appropriate mating connector is included for X1, X3 and X4.
- ▶ The appropriate cable socket and/or appropriate mating connector is **not** included for X2.

NOTICE

Damage to unused plugs due to penetration of humidity!

- ▶ Unused plugs must be covered with the protective caps supplied with the product to ensure IP protection.

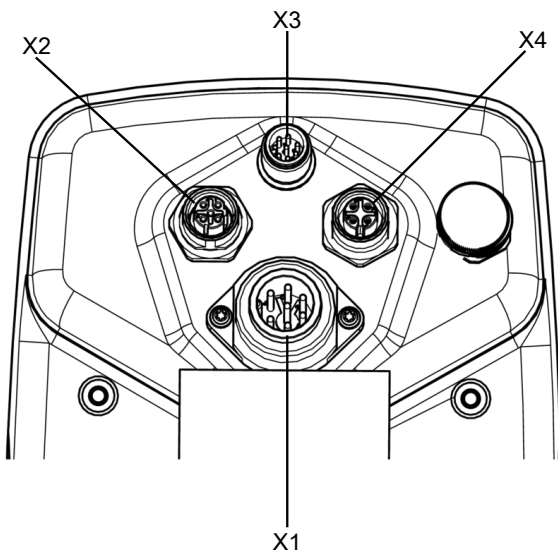
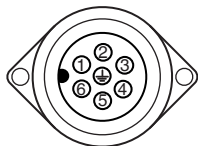

Fig. 7: Overview of electrical connections

9.1 Connection X1



7-pin plug, Binder, type 693

Pin	Signal name
Pin 1	Uv, 24 V DC supply voltage
Pin 2	Uv GND
Pin 3	Relay output K1, common
Pin 4	Relay output K1, make contact
Pin 5	Relay output K2, common
Pin 6	Relay output K2, make contact
Pin PE	Function earth

9.2 Connection X2



5-pin M12 built-in socket, D-coded

Pin	Signal name
Pin 1	Tx + (Ethernet)
Pin 2	Rx + (Ethernet)
Pin 3	Tx - (Ethernet)
Pin 4	Rx - (Ethernet)
Pin 5	Shield

9.3 Connection X3

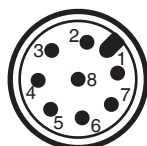

8-pin M12 plug, A-coded

Pin	Signal name
Pin 1	W+ set value input
Pin 2	W – set value input
Pin 3	X + actual value output
Pin 4	GND (actual value output, digital input 1 – 3, error message output)
Pin 5	Error message output 24 V DC
Pin 6	Digital input 3
Pin 7	Digital input 1
Pin 8	Digital input 2

9.4 Connection X4



4-pin M12 built-in socket, A-coded

Pin	Signal name
Pin 1	UV, 24 V DC actual value supply
Pin 2	n.c.
Pin 3	GND (actual value supply, actual value input)
Pin 4	X+, process actual value input
Pin 5	n.c.

9.5 Connecting the product electrically

1. Protect the electrical connections from direct contact with rain water.
2. Lay the cables and pipework so that neither condensate nor rain water can get into the plug unions.
3. Check that all plug cable glands and fittings are mechanically secured.
 - ⇒ The cable must be held firmly on all sides.
4. Check whether the actuator cover/manual override is closed and undamaged.
5. Correctly close the actuator cover/manual override again immediately after use (see "Manual override", page 41).
6. Correctly close the product again after replacing the diaphragm (see "Mounting the diaphragm", page 43).

9.6 Connection diagram

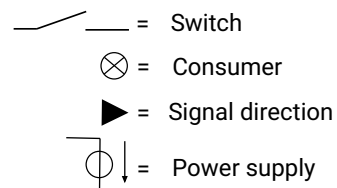
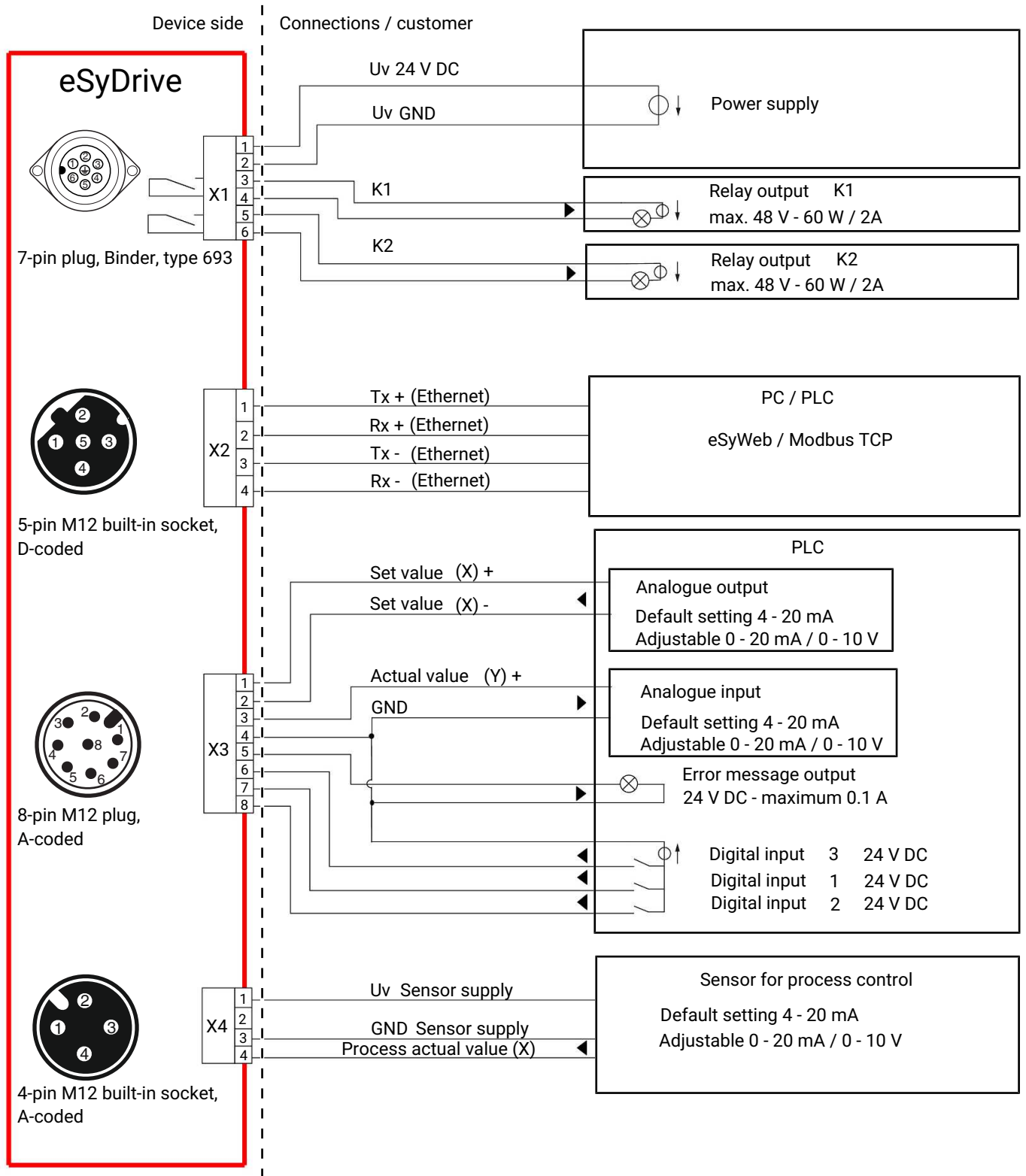

10 Dimensions

10.1 Actuator dimensions

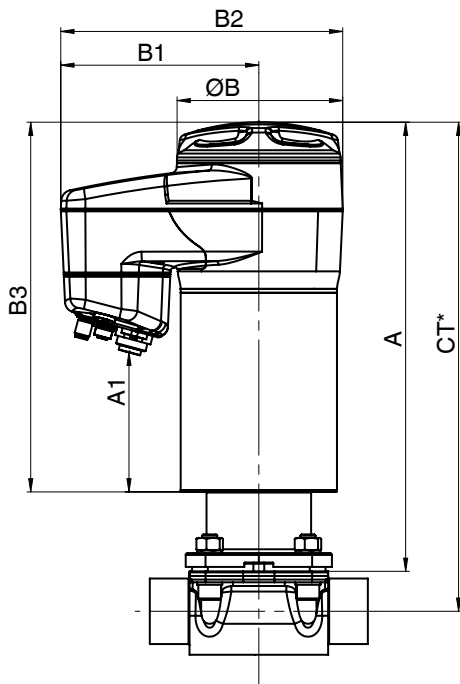

MG	DN	Actuator version	A	A1	Ø B	B1	B2	B3
8	4 - 15	0B	215,9	44.0	68.0	126.0	160.0	190.0
10	10 - 20	0A	230.0	44.0	68.0	126.0	160.0	190.0
25	15 - 25	1A	305.0	83.0	82.0	132.0	172.0	250.0
40	32 - 40	1A	303.0	75.0	82.0	132.0	172.0	243.0
		2A	360.0	111.0	134.0	157.0	224.0	296.0
50	50 - 65	2A	360.0	111.0	134.0	157.0	224.0	296.0

Dimensions in mm

MG = diaphragm size

* CT = A + H1 (see body dimensions)

10.2 Body dimensions

10.2.1 Spigot DIN/EN/ISO (code 0, 16, 17, 18, 60)

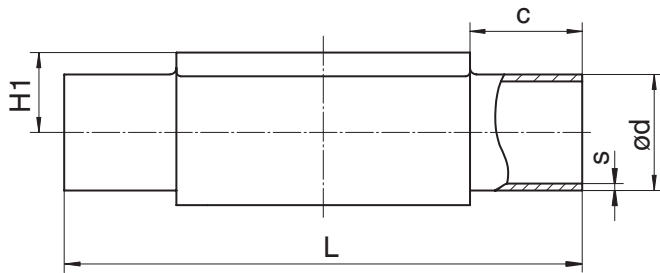

Connection type spigot DIN/EN/ISO (code 0, 16, 17, 18, 60)¹⁾, forged material (code 40, 42, F4)²⁾

MG	DN	NPS	c (min)	ød					H1	L	s				
				Connection type							Connection type				
				0	16	17	18	60			0	16	17	18	60
8	4	-	20.0	6.0	-	-	-	-	8.5	72.0	1.0	-	-	-	-
	6	-	20.0	-	-	8.0	-	10.2	8.5	72.0	-	-	1.0	-	1.6
	8	1/4"	20.0	-	-	10.0	-	13.5	8.5	72.0	-	-	1.0	-	1.6
	10	3/8"	20.0	-	12.0	13.0	14.0	-	8.5	72.0	-	1.0	1.5	2.0	-
10	10	3/8"	25.0	-	12.0	13.0	14.0	17.2	12.5	108.0	-	1.0	1.5	2.0	1.6
	15	1/2"	25.0	18.0	18.0	19.0	20.0	21.3	12.5	108.0	1.5	1.0	1.5	2.0	1.6
25	15	1/2"	25.0	18.0	18.0	19.0	20.0	21.3	19.0	120.0	1.5	1.0	1.5	2.0	1.6
	20	3/4"	25.0	22.0	22.0	23.0	24.0	26.9	19.0	120.0	1.5	1.0	1.5	2.0	1.6
	25	1"	25.0	28.0	28.0	29.0	30.0	33.7	19.0	120.0	1.5	1.0	1.5	2.0	2.0
40	32	1 1/4"	25.0	34.0	34.0	35.0	36.0	42.4	26.0	153.0	1.5	1.0	1.5	2.0	2.0
	40	1 1/2"	30.5	40.0	40.0	41.0	42.0	48.3	26.0	153.0	1.5	1.0	1.5	2.0	2.0
50	50	2"	30.0	52.0	52.0	53.0	54.0	60.3	32.0	173.0	1.5	1.0	1.5	2.0	2.0

Dimensions in mm

MG = diaphragm size

1) Connection type

Code 0: Spigot DIN

Code 16: Spigot DIN EN 10357 series B (2014 edition; formerly DIN 11850 series 1)

Code 17: Spigot EN 10357 series A/DIN 11866 series A formerly DIN 11850 series 2

Code 18: Spigot DIN 11850 series 3

Code 60: Spigot ISO 1127/DIN EN 10357 series C (2014 edition)/DIN 11866 series B

2) Valve body material

Code 40: 1.4435 (F316L), forged body

Code 42: 1.4435 (BN2), forged body, Δ Fe < 0.5%

Code F4: 1.4539, forged body

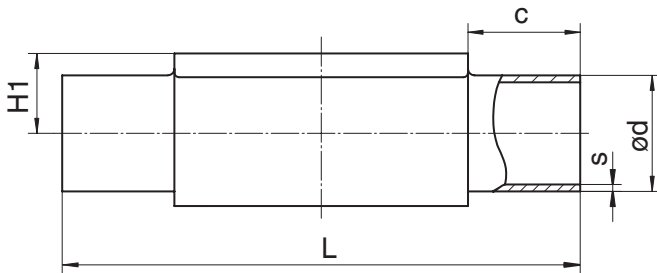

Connection type spigot DIN/EN/ISO (code 0, 17, 60)¹⁾, investment casting material (code C3)²⁾

MG	DN	NPS	c (min)	ød			H1	L	s		
				Connection type					Connection type		
				0	17	60			0	17	60
8	4	-	20.0	6,0	-	-	8.5	72.0	1,0	-	-
	6	-	20.0	-	8.0	-	8.5	72.0	-	1.0	-
	8	1/4"	20.0	-	10.0	13.5	8.5	72.0	-	1.0	1.6
	10	3/8"	20.0	-	13.0	-	8.5	72.0	-	1.5	-
10	10	3/8"	25.0	-	13.0	17.2	12.5	108.0	-	1.5	1.6
	15	1/2"	25.0	-	19.0	21.3	12.5	108.0	-	1.5	1.6
25	15	1/2"	25.0	-	19.0	21.3	13.0	120.0	-	1.5	1.6
	20	3/4"	25.0	-	23.0	26.9	16.0	120.0	-	1.5	1.6
	25	1"	25.0	-	29.0	33.7	19.0	120.0	-	1.5	2.0
40	32	1 1/4"	25.0	-	35.0	42.4	24.0	153.0	-	1.5	2.0
	40	1 1/2"	30.5	-	41.0	48.3	26.0	153.0	-	1.5	2.0
50	50	2"	30.0	-	53.0	60.3	32.0	173.0	-	1.5	2.0

Dimensions in mm

MG = diaphragm size

1) **Connection type**

Code 0: Spigot DIN

Code 17: Spigot EN 10357 series A/DIN 11866 series A formerly DIN 11850 series 2

Code 60: Spigot ISO 1127/DIN EN 10357 series C (2014 edition)/DIN 11866 series B

2) **Valve body material**

Code C3: 1.4435, investment casting

10.2.2 Spigot ASME/BS (code 55, 59, 63, 64, 65)

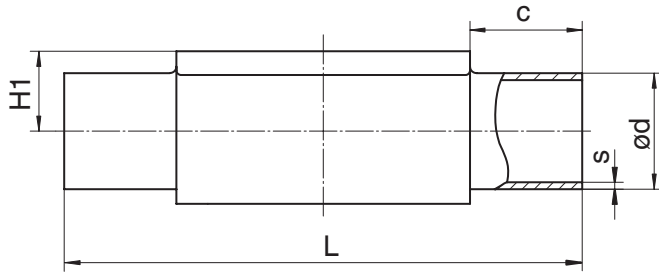

Connection type spigot ASME/BS (code 55, 59, 63, 64, 65)¹⁾, forged material (code 40, 42, F4)²⁾

MG	DN	NPS	c (min)	ød					H1	L	s				
				Connection type							Connection type				
				55	59	63	64	65			55	59	63	64	65
8	6	-	20.0	-	-	10.3	-	10.3	8.5	72.0	-	-	1.24	-	1.73
	8	1/4"	20.0	6.35	6.35	13.7	-	13.7	8.5	72.0	1.2	0.89	1.65	-	2.24
	10	3/8"	20.0	9.53	9.53	-	-	-	8.5	72.0	1.2	0.89	-	-	-
	15	1/2"	20.0	12.70	12.70	-	-	-	8.5	72.0	1.2	1.65	-	-	-
10	10	3/8"	25.0	9.53	9.53	17.1	-	17.1	12.5	108.0	1.2	0.89	1.65	-	2.31
	15	1/2"	25.0	12.70	12.70	21.3	21.3	21.3	12.5	108.0	1.2	1.65	2.11	1.65	2.77
	20	3/4"	25.0	19.05	19.05	-	-	-	12.5	108.0	1.2	1.65	-	-	-
25	15	1/2"	25.0	-	-	21.3	21.3	21.3	19.0	120.0	-	-	2.11	1.65	2.77
	20	3/4"	25.0	19.05	19.05	26.7	26.7	26.7	19.0	120.0	1.2	1.65	2.11	1.65	2.87
	25	1"	25.0	-	25.40	33.4	33.4	33.4	19.0	120.0	-	1.65	2.77	1.65	3.38
40	32	1 1/4"	25.0	-	-	42.2	42.2	42.2	26.0	153.0	-	-	2.77	1.65	3.56
	40	1 1/2"	30.5	-	38.10	48.3	48.3	48.3	26.0	153.0	-	1.65	2.77	1.65	3.68
50	50	2"	30.0	-	50.80	60.3	60.3	60.3	32.0	173.0	-	1.65	2.77	1.65	3.91
	65	2 1/2"	30.0	-	63.50	-	-	-	34.0	173.0	-	1.65	-	-	-

Connection type spigot ASME BPE (code 59)¹⁾, investment casting material (code C3)²⁾

MG	DN	NPS	c (min)	ød	H1	L	s
8	8	1/4"	20.0	6.35	8.5	72.0	0.89
	10	3/8"	20.0	9.53	8.5	72.0	0.89
	15	1/2"	20.0	12.70	8.5	72.0	1.65
10	20	3/4"	25.0	19.05	12.5	108.0	1.65
25	20	3/4"	25.0	19.05	16.0	120.0	1.65
	25	1"	25.0	25.40	19.0	120.0	1.65
40	40	1 1/2"	30.5	38.10	26.0	153.0	1.65
50	50	2"	30.0	50.80	32.0	173.0	1.65

Dimensions in mm

MG = diaphragm size

1) Connection type

Code 55: Spigot BS 4825, part 1

Code 59: Spigot ASME BPE/DIN EN 10357 series C (from 2022 edition)/DIN 11866 series C

Code 63: Spigot ANSI/ASME B36.19M schedule 10s

Code 64: Spigot ANSI/ASME B36.19M schedule 5s

Code 65: Spigot ANSI/ASME B36.19M schedule 40s

2) Valve body material

Code 40: 1.4435 (F316L), forged body

Code 42: 1.4435 (BN2), forged body, Δ Fe < 0.5%

Code C3: 1.4435, investment casting

Code F4: 1.4539, forged body

10.2.3 Spigot JIS/SMS (code 35, 36, 37)

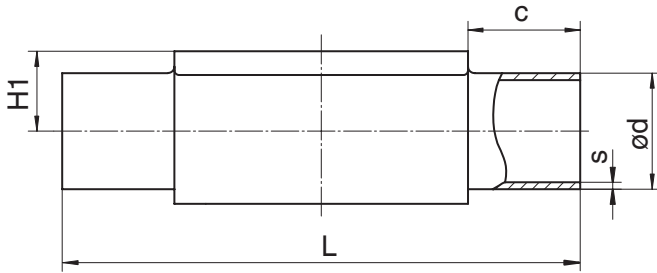

Connection type spigot JIS/SMS (code 35, 36, 37)¹⁾, forged material (code 40, 42, F4)²⁾

MG	DN	NPS	c (min)	ød			H1	L	s		
				Connection type					Connection type		
				35	36	37			35	36	37
8	6	-	20.0	-	10.5	-	8.5	72.0	-	1.20	-
	8	1/4"	20.0	-	13.8	-	8.5	72.0	-	1.65	-
10	10	3/8"	25.0	-	17.3	-	12.5	108.0	-	1.65	-
	15	1/2"	25.0	-	21.7	-	12.5	108.0	-	2.10	-
25	15	1/2"	25.0	-	21.7	-	19.0	120.0	-	2.10	-
	20	3/4"	25.0	-	27.2	-	19.0	120.0	-	2.10	-
	25	1"	25.0	25.4	34.0	25.0	19.0	120.0	1.2	2.80	1.2
40	32	1 1/4"	25.0	31.8	42.7	33.7	26.0	153.0	1.2	2.80	1.2
	40	1 1/2"	30.5	38.1	48.6	38.0	26.0	153.0	1.2	2.80	1.2
50	50	2"	30.0	50.8	60.5	51.0	32.0	173.0	1.5	2.80	1.2
	65	2 1/2"	30.0	63.5	-	63.5	34.0	173.0	2.0	-	1.6

Connection type spigot SMS (code 37)¹⁾, investment casting material (code C3)²⁾

MG	DN	NPS	c (min)	ød	H1	L	s
25	25	1"	25.0	25.0	19.0	120.0	1.2
40	40	1 1/2"	30.5	38.0	26.0	153.0	1.2
50	50	2"	30.0	51.0	32.0	173.0	1.2

Dimensions in mm

MG = diaphragm size

1) Connection type

Code 35: Spigot JIS-G 3447

Code 36: Spigot JIS-G 3459 schedule 10s

Code 37: Spigot SMS 3008

2) Valve body material

Code 40: 1.4435 (F316L), forged body

Code 42: 1.4435 (BN2), forged body, Δ Fe < 0.5%

Code C3: 1.4435, investment casting

Code F4: 1.4539, forged body

10.2.4 Threaded socket DIN (code 1)

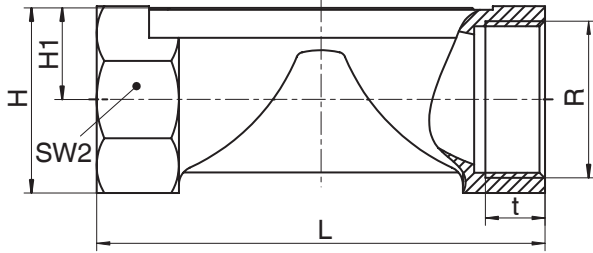

Connection type threaded socket (code 1)¹⁾, brass material (code 12)²⁾

MG	DN	NPS	H	H1	L	n	R	SW 2	t
10	12	3/8"	23.0	11.0	55.0	2	G 3/8	22.0	13.0
	15	1/2"	29.0	14.0	75.0	2	G 1/2	25.0	15.0

Connection type threaded socket (code 1)¹⁾, investment casting material (code 37)²⁾

MG	DN	NPS	H	H1	L	n	R	SW 2	t
8	8	1/4"	19.0	9.0	72.0	6	G 1/4	18.0	11.0
10	12	3/8"	25.0	13.0	55.0	2	G 3/8	22.0	12.0
	15	1/2"	30.0	15.0	68.0	2	G 1/2	27.0	15.0
25	15	1/2"	28.3	14.8	85.0	6	G 1/2	27.0	15.0
	20	3/4"	33.3	17.3	85.0	6	G 3/4	32.0	16.0
	25	1"	42.3	21.8	110.0	6	G 1	41.0	13.0
40	32	1 1/4"	51.3	26.3	120.0	8	G 1 1/4	50.0	20.0
	40	1 1/2"	56.3	28.8	140.0	8	G 1 1/2	55.0	18.0
50	50	2"	71.3	36.0	165.0	8	G 2	70.0	26.0

Connection type threaded socket (code 1)¹⁾, SG iron material (code 90)²⁾

MG	DN	NPS	H	H1	L	n	R	SW 2	t
25	15	1/2"	32.7	16.7	85.0	6	G 1/2	32	15.0
	20	3/4"	42.0	21.5	85.0	6	G 3/4	41	16.3
	25	1"	46.7	23.7	110.0	6	G 1	46	19.1
40	32	1 1/4"	56.0	28.5	120.0	6	G 1 1/4	55	21.4
	40	1 1/2"	66.0	33.5	140.0	6	G 1 1/2	65	21.4
50	50	2"	76.0	38.5	165.0	6	G 2	75	25.7

Dimensions in mm

MG = diaphragm size

n = number of flats

1) Connection type

Code 1: Threaded socket DIN ISO 228

2) Valve body material

Code 12: CW614N, CW617N (brass)

Code 37: 1.4408, investment casting

Code 90: EN-GJS-400-18-LT (GGG 40.3)

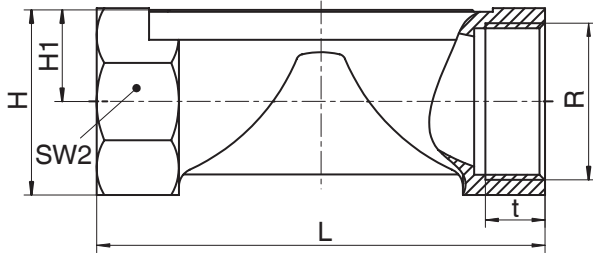
10.2.5 Threaded socket NPT (code 31)**Connection type threaded socket NPT (code 31)¹⁾, investment casting material (code 37)²⁾**

MG	DN	NPS	H	H1	L	n	R	SW 2	t
25	15	1/2"	28.3	14.8	85.0	6	NPT 1/2	27.0	14.0
	20	3/4"	33.3	17.3	85.0	6	NPT 3/4	32.0	14.0
	25	1"	42.3	21.8	110.0	6	NPT 1	41.0	17.0
40	32	1 1/4"	51.3	26.3	120.0	8	NPT 1 1/4	50.0	17.0
	40	1 1/2"	56.3	28.8	140.0	8	NPT 1 1/2	55.0	17.0
50	50	2"	71.3	36.3	165.0	8	NPT 2	70.0	18.0

Connection type threaded socket NPT (code 31)¹⁾, SG iron material (code 90)²⁾

MG	DN	NPS	H	H1	L	n	R	SW 2	t
25	15	1/2"	32.7	16.7	85.0	6	NPT 1/2	32	13.6
	20	3/4"	42.0	21.5	85.0	6	NPT 3/4	41	14.1
	25	1"	46.7	23.7	110.0	6	NPT 1	46	16.8
40	32	1 1/4"	56.0	28.5	120.0	6	NPT 1 1/4	55	17.3
	40	1 1/2"	66.0	33.5	140.0	6	NPT 1 1/2	65	17.3
50	50	2"	76.0	38.5	165.0	6	NPT 2	75	17.7

Dimensions in mm

MG = diaphragm size

n = number of flats

1) Connection type

Code 31: NPT female thread

2) Valve body material

Code 37: 1.4408, investment casting

Code 90: EN-GJS-400-18-LT (GGG 40.3)

10.2.6 Threaded spigot DIN (code 6)

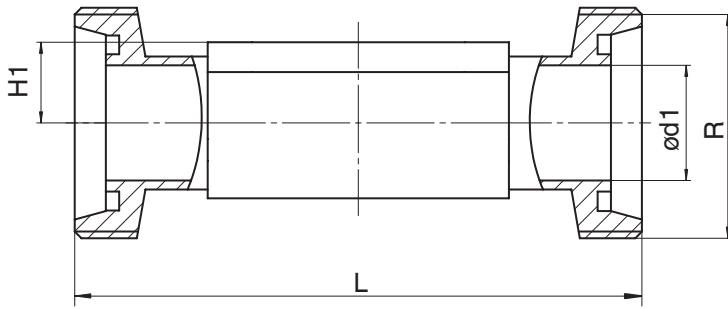

Connection type threaded spigot DIN (code 6)¹⁾, forged material (code 40, 42)²⁾

MG	DN	NPS	ød1	H1	L	R
8	10	3/8"	10.0	8.5	92.0	Rd 28 x 1/8
10	10	3/8"	10.0	12.5	118.0	Rd 28 x 1/8
	15	1/2"	16.0	12.5	118.0	Rd 34 x 1/8
25	15	1/2"	16.0	19.0	118.0	Rd 34 x 1/8
	20	3/4"	20.0	19.0	118.0	Rd 44 x 1/6
	25	1"	26.0	19.0	128.0	Rd 52 x 1/6
40	32	1¼"	32.0	26.0	147.0	Rd 58 x 1/6
	40	1½"	38.0	26.0	160.0	Rd 65 x 1/6
50	50	2"	50.0	32.0	191.0	Rd 78 x 1/6

Dimensions in mm

MG = diaphragm size

1) Connection type

Code 6: Threaded spigot DIN 11851

2) Valve body material

Code 40: 1.4435 (F316L), forged body

Code 42: 1.4435 (BN2), forged body, Δ Fe < 0.5%

10.2.7 Cone spigot DIN (code 6K)

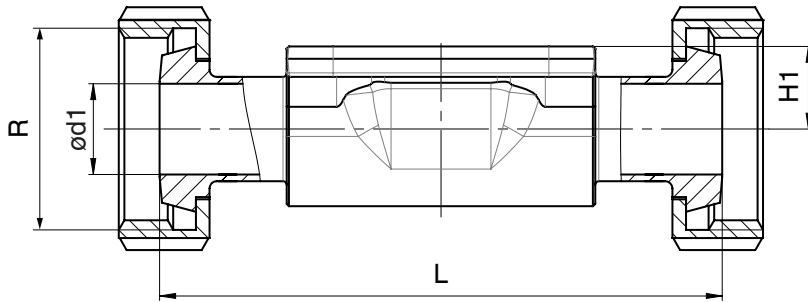

Connection type cone spigot DIN (code 6K)¹⁾, forged material (code 40, 42)²⁾

MG	DN	NPS	ød1	H1	L	R
8	10	3/8"	10.0	8.5	90.0	Rd 28 x 1/8
10	10	3/8"	10.0	12.5	116.0	Rd 28 x 1/8
	15	1/2"	16.0	12.5	116.0	Rd 34 x 1/8
25	15	1/2"	16.0	19.0	116.0	Rd 34 x 1/8
	20	3/4"	20.0	19.0	114.0	Rd 44 x 1/6
	25	1"	26.0	19.0	127.0	Rd 52 x 1/6
40	32	1¼"	32.0	26.0	147.0	Rd 58 x 1/6
	40	1½"	38.0	26.0	160.0	Rd 65 x 1/6
50	50	2"	50.0	32.0	191.0	Rd 78 x 1/6

Dimensions in mm

MG = diaphragm size

1) **Connection type**

Code 6K: Cone spigot and union nut DIN 11851

2) **Valve body material**

Code 40: 1.4435 (F316L), forged body

Code 42: 1.4435 (BN2), forged body, $\Delta Fe < 0.5\%$

10.2.8 Flange EN (code 8)

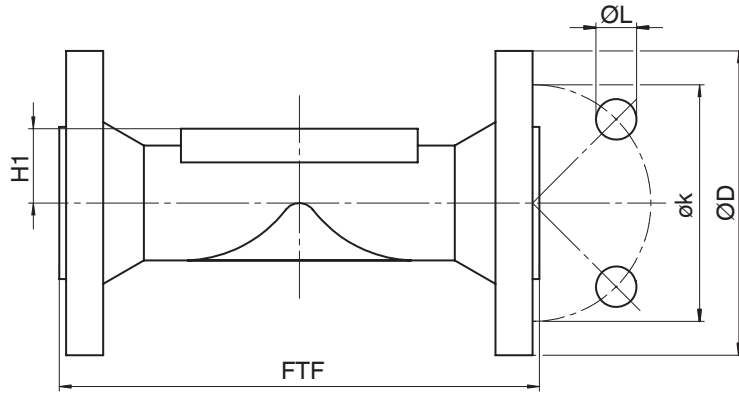

Connection type flange, length EN 558 (code 8)¹⁾, SG iron material (code 17, 18, 83, 90), investment casting material (code 39, C3), forged material (code 40, 42)²⁾

MG	DN	NPS	øD	FTF		H1				øk	øL	n
				Material		Material						
				17, 18, 39, 83, 90	40, 42, C3	17, 18, 39, 83	40, 42	C3	90			
25	15	1/2"	95.0	130.0	150.0	18.0	19.0	13.0	14.0	65.0	14.0	4
	20	3/4"	105.0	150.0	150.0	20.5	19.0	16.0	16.5	75.0	14.0	4
	25	1"	115.0	160.0	160.0	23.0	19.0	19.0	19.5	85.0	14.0	4
40	32	1¼"	140.0	180.0	180.0	28.7	26.0	24.0	23.0	100.0	19.0	4
	40	1½"	150.0	200.0	200.0	33.0	26.0	26.0	27.0	110.0	19.0	4
50	50	2"	165.0	230.0	230.0	39.0	32.0	32.0	32.0	125.0	19.0	4
	65	2½"	185.0	290.0	-	51.0	-	-	38.7	145.0	19.0	4

Dimensions in mm

MG = diaphragm size

n = number of bolt holes

1) Connection type

Code 8: Flange EN 1092, PN 16, form B, face-to-face dimension FTF EN 558 series 1, ISO 5752, basic series 1, length only for body configuration D

2) Valve body material

Code 17: EN-GJS-400-18-LT (GGG 40.3), PFA lined

Code 18: EN-GJS-400-18-LT (GGG 40.3), PP lined

Code 39: 1.4408, PFA lined

Code 40: 1.4435 (F316L), forged body

Code 42: 1.4435 (BN2), forged body, Δ Fe < 0.5%

Code 83: EN-GJS-400-18-LT (GGG 40.3), hard rubber lined

Code 90: EN-GJS-400-18-LT (GGG 40.3)

Code C3: 1.4435, investment casting

10.2.9 Flange JIS (code 34)

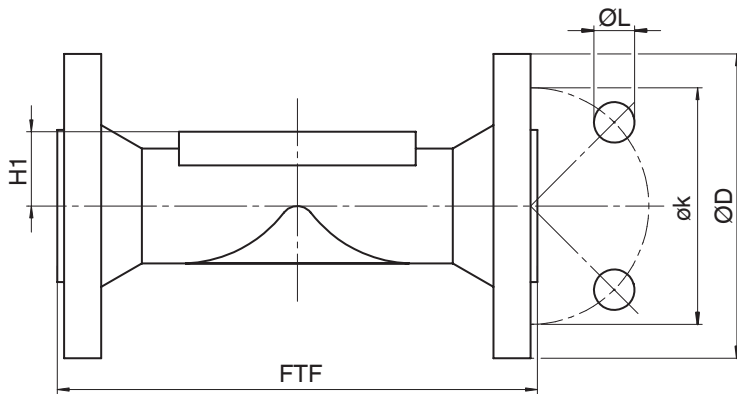

Connection type flange, length 558 (code 34)¹⁾, investment casting material (code 39)²⁾

MG	DN	NPS	øD	FTF	H1	øk	øL	n
25	15	1/2"	95.0	130.0	18.0	70.0	15.0	4
	20	3/4"	100.0	150.0	20.5	75.0	15.0	4
	25	1"	125.0	160.0	23.0	90.0	19.0	4
40	32	1¼"	135.0	180.0	28.7	100.0	19.0	4
	40	1½"	140.0	200.0	33.0	105.0	19.0	4
50	50	2"	155.0	230.0	39.0	120.0	19.0	4

Dimensions in mm

MG = diaphragm size

1) Connection type

Code 34: Flange JIS B2220, 10K, RF, face-to-face dimension FTF EN 558 series 1, ISO 5752, basic series 1, length only for body configuration D

2) Valve body material

Code 39: 1.4408, PFA lined

10.2.10 Flange ANSI Class (code 38, 39)

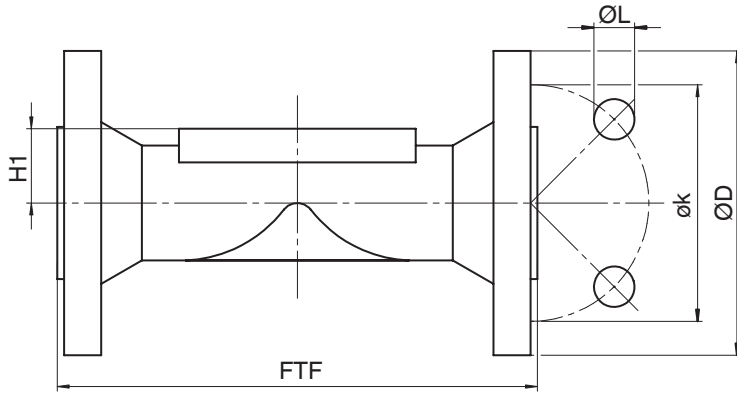

Connection type flange, length MSS SP-88 (code 38)¹⁾, SG iron material (code 17, 18, 83), investment casting material (code 39)²⁾

MG	DN	NPS	øD	FTF		H1	øk	øL	n
				Material					
				17, 18, 39	83				
25	20	3/4"	100.0	146.0	146.4	20.5	69.9	15.9	4
	25	1"	110.0	146.0	146.4	23.0	79.4	15.9	4
40	40	1½"	125.0	175.0	171.4	33.0	98.4	15.9	4
50	50	2"	150.0	200.0	197.4	39.0	120.7	19.0	4
	65	2½"	180.0	226.0	222.4	51.0	139.7	19.0	4

Dimensions in mm

MG = diaphragm size

n = number of bolt holes

1) Connection type

Code 38: Flange ANSI Class 150 RF, face-to-face dimension FTF MSS SP-88, length only for body configuration D

2) Valve body material

Code 17: EN-GJS-400-18-LT (GGG 40.3), PFA lined

Code 18: EN-GJS-400-18-LT (GGG 40.3), PP lined

Code 39: 1.4408, PFA lined

Code 83: EN-GJS-400-18-LT (GGG 40.3), hard rubber lined

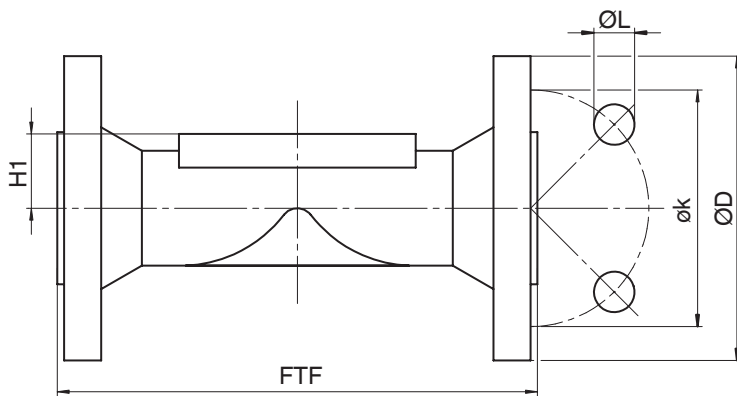

Connection type flange, length EN 558 (code 39)¹⁾, SG iron material (code 17, 18, 83, 90), investment casting material (code 39, C3), forged material (code 40, 42)²⁾

MG	DN	NPS	øD	FTF		H1				øk	øL	n
				Material		Material						
				17, 18, 39, 83, 90	40, 42, C3	17, 18, 39, 83	C3	40, 42	90			
25	15	1/2"	90.0	130.0	150.0	-	13.0	19.0	14.0	60.3	15.9	4
	20	3/4"	100.0	150.0	150.0	20.5	16.0	19.0	16.5	69.9	15.9	4
	25	1"	110.0	160.0	160.0	23.0	19.0	19.0	19.5	79.4	15.9	4
40	32	1¼"	115.0	180.0	180.0	28.7	24.0	26.0	23.0	88.9	15.9	4
	40	1½"	125.0	200.0	200.0	33.0	26.0	26.0	27.0	98.4	15.9	4
50	50	2"	150.0	230.0	230.0	39.0	32.0	32.0	32.0	120.7	19.0	4
	65	2½"	180.0	290.0	-	51.0	-	-	38.7	139.7	19.0	4

Dimensions in mm

MG = diaphragm size

n = number of bolt holes

1) Connection type

Code 39: Flange ANSI Class 125/150 RF, face-to-face dimension FTF EN 558 series 1, ISO 5752, basic series 1, length only for body configuration D

2) Valve body material

Code 17: EN-GJS-400-18-LT (GGG 40.3), PFA lined

Code 18: EN-GJS-400-18-LT (GGG 40.3), PP lined

Code 39: 1.4408, PFA lined

Code 40: 1.4435 (F316L), forged body

Code 42: 1.4435 (BN2), forged body, Δ Fe < 0.5%

Code 83: EN-GJS-400-18-LT (GGG 40.3), hard rubber lined

Code 90: EN-GJS-400-18-LT (GGG 40.3)

Code C3: 1.4435, investment casting

10.2.11 Clamp (code 80, 82, 88, 8A, 8E, 8P, 8T)

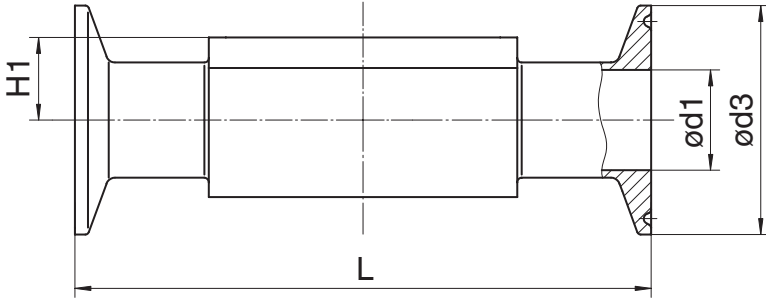

Connection type clamp DIN/ASME (code 80, 88, 8P, 8T)¹⁾, forged material (code 40, 42, F4)²⁾

MG	DN	NPS	ød1		ød3		H1	L	
			Connection type		Connection type			Connection type	
			80, 8P	88, 8T	80, 8P	88, 8T		80, 8P	88, 8T
8	8	1/4"	4.57	-	25.0	-	8.5	63.5	-
	10	3/8"	7.75	-	25.0	-	8.5	63.5	-
	15	1/2"	9.40	9.40	25.0	25.0	8.5	63.5	108.0
10	15	1/2"	9.40	9.40	25.0	25.0	12.5	88.9	108.0
	20	3/4"	15.75	15.75	25.0	25.0	12.5	101.6	117.0
25	20	3/4"	15.75	15.75	25.0	25.0	19.0	101.6	117.0
	25	1"	22.10	22.10	50.5	50.5	19.0	114.3	127.0
40	40	1½"	34.80	34.80	50.5	50.5	26.0	139.7	159.0
50	50	2"	47.50	47.50	64.0	64.0	32.0	158.8	190.0
	65	2½"	60.20	60.20	77.5	77.5	34.0	193.8	216.0

Dimensions in mm

MG = diaphragm size

1) Connection type

Code 80: Clamp ASME BPE, face-to-face dimension FTF ASME BPE, length only for body configuration D

Code 88: Clamp ASME BPE, for pipe ASME BPE, face-to-face dimension FTF EN 558 series 7, length only for body configuration D

Code 8P: Clamp DIN 32676 series C, face-to-face dimension FTF ASME BPE, length only for body configuration D

Code 8T: Clamp DIN 32676 series C, face-to-face dimension FTF EN 558 series 7, length only for body configuration D

2) Valve body material

Code 40: 1.4435 (F316L), forged body

Code 42: 1.4435 (BN2), forged body, Δ Fe < 0.5%

Code F4: 1.4539, forged body

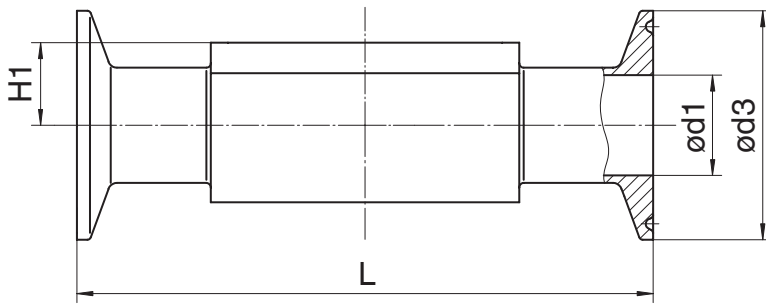

Connection type clamp DIN/ISO (code 82, 8A, 8E)¹⁾, forged material (code 40, 42, F4)²⁾

MG	DN	NPS	ød1			ød3			H1	L		
			Connection type			Connection type				Connection type		
			82	8A	8E	82	8A	8E		82	8A	8E
8	6	1/8"	7.0	6.0	-	25.0	25.0	-	8.5	63.5	63.5	-
	8	1/4"	10.3	8.0	-	25.0	25.0	-	8.5	63.5	63.5	-
	10	3/8"	-	10.0	-	-	34.0	-	8.5	-	88.9	-
10	10	3/8"	14.0	10.0	-	25.0	34.0	-	12.5	108.0	108.0	-
	15	1/2"	18.1	16.0	-	50.5	34.0	-	12.5	108.0	108.0	-
25	15	1/2"	18.1	16.0	-	50.5	34.0	-	19.0	108.0	108.0	-
	20	3/4"	23.7	20.0	-	50.5	34.0	-	19.0	117.0	117.0	-
	25	1"	29.7	26.0	22.6	50.5	50.5	50.5	19.0	127.0	127.0	127.0
40	32	1 1/4"	38.4	32.0	31.3	64.0	50.5	50.5	26.0	146.0	146.0	146.0
	40	1 1/2"	44.3	38.0	35.6	64.0	50.5	50.5	26.0	159.0	159.0	159.0
50	50	2"	56.3	50.0	48.6	77.5	64.0	64.0	32.0	190.0	190.0	190.0
	65	2 1/2"	-	-	60.3	-	-	77.5	34.0	-	-	216.0

1) **Connection type**

Code 82: Clamp DIN 32676 series B, face-to-face dimension FTF EN 558 series 7, length only for body configuration D

Code 8A: Clamp DIN 32676 series A, face-to-face dimension FTF acc. to EN 558 series 7, length only for body configuration D

Code 8E: Clamp ISO 2852 for pipe ISO 2037, clamp SMS 3017 for pipe SMS 3008 face-to-face dimension FTF EN 558 series 7, length only for body configuration D

2) **Valve body material**

Code 40: 1.4435 (F316L), forged body

Code 42: 1.4435 (BN2), forged body, Δ Fe < 0.5%

Code F4: 1.4539, forged body

11 Delivery

- Check that all parts are present and check for any damage immediately upon receipt.

The product's performance is tested at the factory. The scope of delivery is apparent from the dispatch documents and the design from the order number.

12 Transport

1. Only transport the product by suitable means. Do not drop. Handle carefully.
2. After the installation dispose of transport packaging material according to relevant local or national disposal regulations / environmental protection laws.

13 Storage

1. Store the product free from dust and moisture in its original packaging.
2. Avoid UV rays and direct sunlight.
3. Do not exceed the maximum storage temperature (see chapter "Technical data").
4. Do not store solvents, chemicals, acids, fuels or similar fluids in the same room as GEMÜ products and their spare parts.
5. Close the compressed air connections with protection caps or sealing plugs.

14 Installation in piping

14.1 Preparing for installation

WARNING

The equipment is subject to pressure!

- ▶ Risk of severe injury or death
- Depressurize the plant.
- Completely drain the plant.

WARNING



Corrosive chemicals!

- ▶ Risk of caustic burns
- Wear appropriate protective gear.
- Completely drain the plant.

CAUTION



Hot plant components!

- ▶ Risk of burns
- Only work on plant that has cooled down.

CAUTION

Exceeding the maximum permissible pressure.

- ▶ Damage to the product
- Provide precautionary measures against exceeding the maximum permitted pressures caused by pressure surges (water hammer).

CAUTION

Use as step.

- ▶ Damage to the product
- ▶ Risk of slipping-off
- Choose the installation location so that the product cannot be used as a foothold.
- Do not use the product as a step or a foothold.

NOTICE

Suitability of the product!

- ▶ The product must be appropriate for the piping system operating conditions (medium, medium concentration, temperature and pressure) and the prevailing ambient conditions.

NOTICE**Tools**

- ▶ The tools required for installation and assembly are not included in the scope of delivery.
 - Use appropriate, functional and safe tools.
1. Ensure the product is suitable for the relevant application.
 2. Check the technical data of the product and the materials.
 3. Keep appropriate tools ready.
 4. Wear appropriate protective gear, as specified in the plant operator's guidelines.
 5. Observe appropriate regulations for connections.
 6. Have installation work carried out by trained personnel.
 7. Shut off plant or plant component.
 8. Secure plant or plant component against recommissioning.
 9. Depressurize the plant or plant component.
 10. Completely drain the plant (or plant component) and let it cool down until the temperature is below the media vaporization temperature and cannot cause scalding.
 11. Correctly decontaminate, rinse and ventilate the plant or plant component.
 12. Lay piping so that the product is protected against transverse and bending forces, and also from vibrations and tension.
 13. Only install the product between matching aligned pipes (see chapters below).
 14. Please note the flow direction (see chapter "Flow direction").
 15. Please note the installation position (see chapter "Installation position").

14.2 Installation position

The installation position of the product is optional.

14.3 Installation with clamp connections

Fig. 8: Clamp connection

NOTICE**Gasket and clamp!**

- ▶ The gasket and clamps for clamp connections are not included in the scope of delivery.
1. Keep ready gasket and clamp.
 2. Carry out preparation for installation (see chapter "Preparing for installation").
 3. Insert the corresponding gasket between the body of the product and the pipe connection.
 4. Connect the gasket between the body of the product and the pipe connection using clamps.
 5. Re-attach or reactivate all safety and protective devices.

14.4 Installation with butt weld spigots

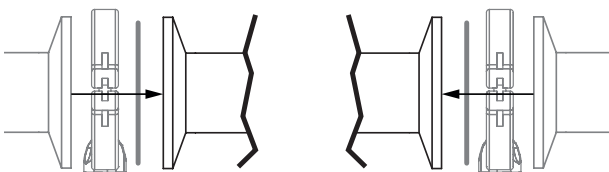
Fig. 9: Butt weld spigots

1. Carry out preparations for installation (see chapter "Preparing for installation").
2. Adhere to good welding practices!
3. Disassemble the actuator with the diaphragm before welding in the valve body (see "Removing the actuator" chapter).
4. Weld the body of the product in the piping.
5. Allow butt weld spigots to cool down.
6. Reassemble the valve body and the actuator with diaphragm (see "Mounting the actuator" chapter).
7. Re-attach or reactivate all safety and protective devices.
8. Flush the system.

14.5 Installation with threaded sockets

Fig. 10: Threaded socket

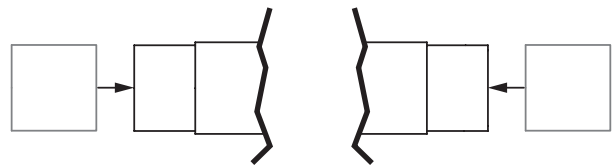
NOTICE

Sealing material!

- ▶ The sealing material is not included in the scope of delivery.
- Only use appropriate sealing material.

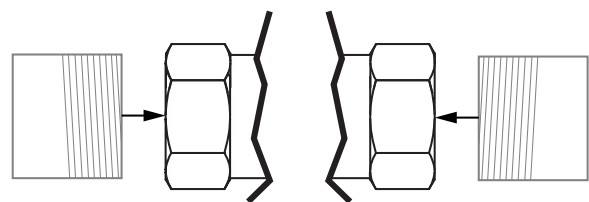
1. Keep thread sealant ready.
2. Carry out preparations for installation (see chapter "Preparing for installation").
3. Screw the threaded connections into the pipe in accordance with valid standards.
4. Screw the body of the product onto the piping using appropriate thread sealant.
5. Re-attach or reactivate all safety and protective devices.

14.6 Installation with threaded spigots

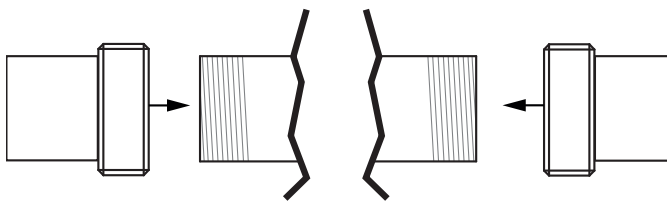

Fig. 11: Threaded spigots

NOTICE

Thread sealant!

- ▶ The thread sealant is not included in the scope of delivery.
- Only use appropriate thread sealant.

1. Keep thread sealant ready.
2. Carry out preparations for installation (see chapter "Preparing for installation").
3. Screw the pipe into the threaded connection of the valve body in accordance with valid standards.
 - ⇒ Use appropriate thread sealant.
4. Re-attach or reactivate all safety and protective devices.

14.7 Installation with flanged connection

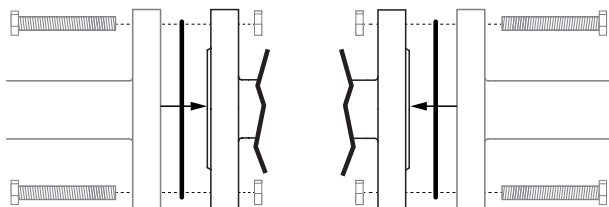

Fig. 12: Flanged connection

NOTICE

Sealing material!

- ▶ The sealing material is not included in the scope of delivery.
- Only use appropriate sealing material.

NOTICE

Connector elements!

- ▶ The connector elements are not included in the scope of delivery.
- Only use connector elements made of approved materials.
- Observe permissible tightening torque of the bolts.

1. Keep sealing material ready.
2. Carry out preparations for installation (see chapter "Preparing for installation").
3. Ensure clean, undamaged sealing surfaces on the connection flanges.
4. Align flanges carefully before installing them.
5. Clamp the product centrally between the piping with flanges.
6. Centre the gaskets.
7. Connect the valve flange and the piping flange using appropriate sealing materials and matching bolting.
8. Use all flange holes.
9. Tighten the bolts diagonally.
10. Re-attach or reactivate all safety and protective devices.

15 Network connection

15.1 Network settings

The network interface has the following default settings:

IP address: 192.168.2.1

Subnet screen: 255.255.252.0

The default settings can be changed. See the eSy-Web operating instructions.

15.2 Connecting the network

1. Connect the network plug and cables with the electrical connection X2 of the product.
2. Change the IP address using the web server.

15.3 Resetting the network settings

1. Ensure that the "ON-Site" DIP switch **8** is not in the "ON" position.
2. Press and hold down the "OPEN" button **9** for at least 8 s.
 - ⇒ LED 1 flashes fast in blue.
3. Press the "INIT/CLOSE" button **10**.
 - ⇒ Network settings are reset in the default settings.

16 Commissioning

16.1 Commissioning on the device

1. Ensure that the "ON-Site" DIP switch 8 is not in the "ON" position (see "Buttons for on-site control", page 6).
2. Press and hold down the "INIT/CLOSE" button 10 for at least 8 s.
 - ⇒ Initialization of the actuator begins.
3. Green and orange LEDs flash alternately.
 - ⇒ Initialization is completed.
- ⇒ Commissioning is completed.

16.2 Commissioning via the eSy-Web web interface

- See separate eSy-Web operating instructions.

16.3 Commissioning via digital input

- ✓ The function of input 3 is set to init.
1. Apply 24 V DC signal briefly (max. 2 s) to connection X3 pin 6 (reference GND connection X3 pin 4).
 - ⇒ Initialization of the actuator begins.
 2. Green and orange LEDs flash alternately.
 - ⇒ Initialization is completed.
 - ⇒ Commissioning is completed.

17 Operation

17.1 Operation on the device

17.1.1 Moving the valve to the open position

1. Move the "ON-Site" DIP switch 8 to the "ON" position (see "Buttons for on-site control", page 6).
 - ⇒ Control on the device is activated.
2. Press the "OPEN" button 9.
 - ⇒ The valve moves slowly to the open position.
3. Also press the "INIT/CLOSE" button 10.
 - ⇒ The valve moves quickly to the open position.
 - ⇒ If the valve is fully opened, the high visibility LEDs are lit in green.
4. Move the "ON-Site" DIP switch 8 to the "OFF" position.
 - ⇒ Control on the device is deactivated.
- ⇒ The valve is in the open position.

17.1.2 Moving the valve to the closed position

1. Move the "ON-Site" DIP switch 8 to the "ON" position.
 - ⇒ Control on the device is activated.
2. Press the "INIT/CLOSE" button 10.
 - ⇒ The valve moves slowly to the closed position.
3. Also press the "OPEN" button 9.
 - ⇒ The valve moves quickly to the closed position.

⇒ If the valve is fully closed, the high visibility LEDs are lit in orange.

4. Move the "ON-Site" DIP switch 8 to the "OFF" position.
 - ⇒ Control on the device is deactivated.
 - ⇒ The valve is in the closed position.

17.2 Operation via the web server

See separate "eSy-Web" operating instructions.

17.3 Manual override

⚠ WARNING	
	<p>Rotating cover!</p> <ul style="list-style-type: none"> ▶ Risk of crushing. ● Disconnect the power supply before using the manual override.

1. Disconnect the power supply.
2. Turn housing cover 3 clockwise.
3. Remove housing cover 3.

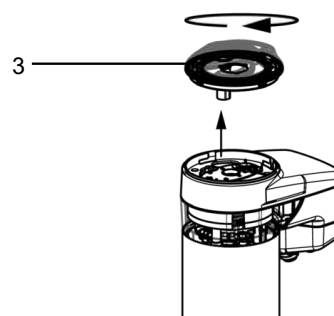

4. Place the actuator of housing cover 12 in the starting point for manual override.

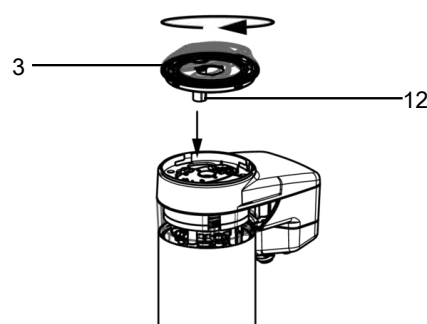

Item	Name
3	Housing cover
12	Housing cover actuator

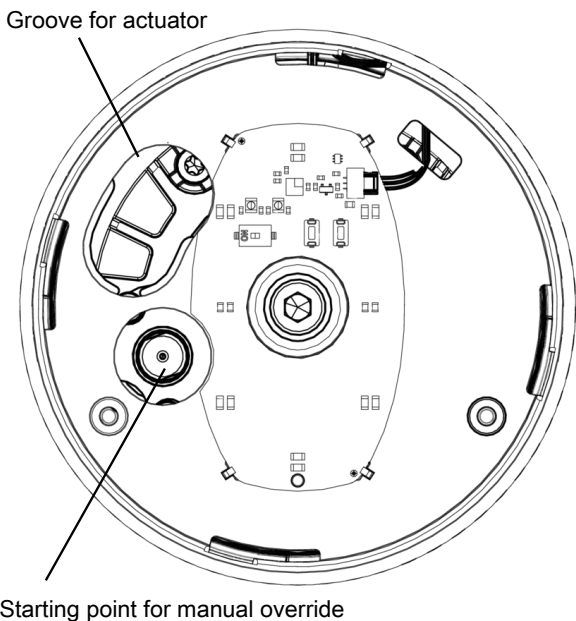

5. Turn housing cover **3** anticlockwise.
⇒ The product opens.
6. Turn housing cover **3** clockwise.
⇒ The product closes.
7. Pull manual override off the starting point.
8. Ensure correct positioning of the O-ring.
9. Push actuator **12** into the groove provided for this purpose.
10. Turn housing cover **3** anticlockwise until it stops.
⇒ The actuator cover is closed.
11. Reconnect the power supply.

18 Inspection and maintenance

WARNING

The equipment is subject to pressure!

- ▶ Risk of severe injury or death
- Depressurize the plant or plant component.
- Completely drain the plant or plant component.

CAUTION

Use of incorrect spare parts!

- ▶ Damage to the GEMÜ product
- ▶ Manufacturer liability and guarantee will be void
- Use only genuine parts from GEMÜ.

CAUTION



Hot plant components!

- ▶ Risk of burns
- Only work on plant that has cooled down.

NOTICE

Exceptional maintenance work!

- ▶ Damage to the GEMÜ product
- Any maintenance work and repairs not described in these operating instructions must not be performed without consulting the manufacturer first.

The operator must carry out regular visual examination of the GEMÜ products dependent on the operating conditions and the potential danger in order to prevent leakage and damage.

The product also must be disassembled and checked for wear in the corresponding intervals.

1. Have servicing and maintenance work performed by trained personnel.
2. Wear appropriate protective gear as specified in plant operator's guidelines.
3. Shut off plant or plant component.
4. Secure the plant or plant component against recommissioning.
5. Depressurize the plant or plant component.
6. Actuate GEMÜ products which are always in the same position four times a year.

18.1 Spare parts

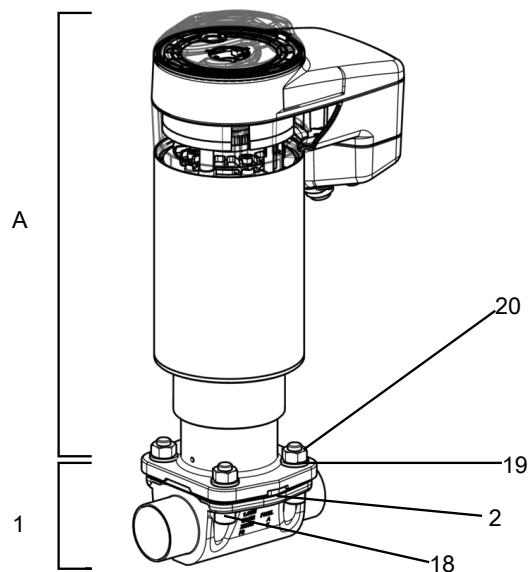

Fig. 13: Spare parts

Item	Name	Order description
A	Actuator	9649
1	Valve body	K600
2	Diaphragm	600...M
18	Bolt	649...S30...
19	Washer	
20	Nut	

18.2 Removing the actuator

1. Move the actuator **A** to the open position.
2. Loosen the fastening elements between actuator **A** and valve body **1** diagonally and remove them.
3. Lift actuator **A** off valve body **1**.
4. Move the actuator **A** to the closed position.
5. Clean all parts of contamination (do not damage parts during cleaning).
6. Check parts for potential damage, replace if necessary (only use genuine parts from GEMÜ).

18.3 Removing the diaphragm

1. Remove actuator **A** (see chapter "Removing the actuator").
2. Unscrew the diaphragm.
 - ⇒ Please note: Depending on the version, the compressor may fall out.
3. Clean all parts of contamination (do not damage parts during cleaning).
4. Check parts for potential damage, replace if necessary (only use genuine parts from GEMÜ).

18.4 Mounting the compressor

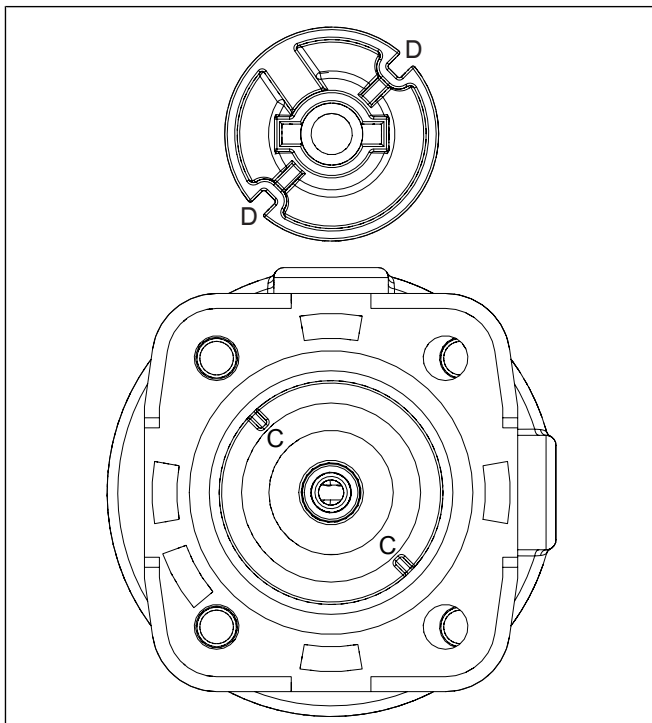

1. Place the compressor loosely on the actuator spindle.
2. Fit recesses **D** into guides **C**.
 - ⇒ The compressor must be able to be moved freely between the guides.

18.5 Mounting the diaphragm

18.5.1 Mounting the convex diaphragm

NOTICE

- Fit the diaphragms suitable for the product (suitable for medium, medium concentration, temperature and pressure). The diaphragm is a wearing part. Check the technical condition and function of the product before commissioning and during the whole term of use. Carry out checks regularly and determine the check intervals in accordance with the conditions of use and/or the regulatory codes and provisions applicable for this application.

NOTICE

- If the diaphragm is not screwed into the adapter far enough, the closing force is transmitted directly onto the diaphragm pin and not via the compressor. This will cause damage and early failure of the diaphragm and leakage of the product. If the diaphragm is screwed in too far, perfect sealing at the valve seat will not be achieved. The function of the product is no longer ensured.

NOTICE

- Incorrectly mounted diaphragms cause the product leakage and emission of medium. In this case, remove the diaphragms, check the complete valve and diaphragms and reassemble again proceeding as described above.

NOTICE

- The compressor is loose and can fall out.

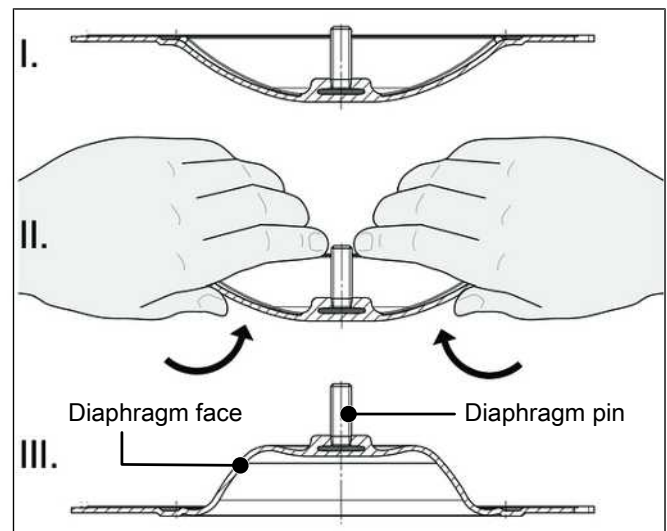

Fig. 14: Inverting the diaphragm face

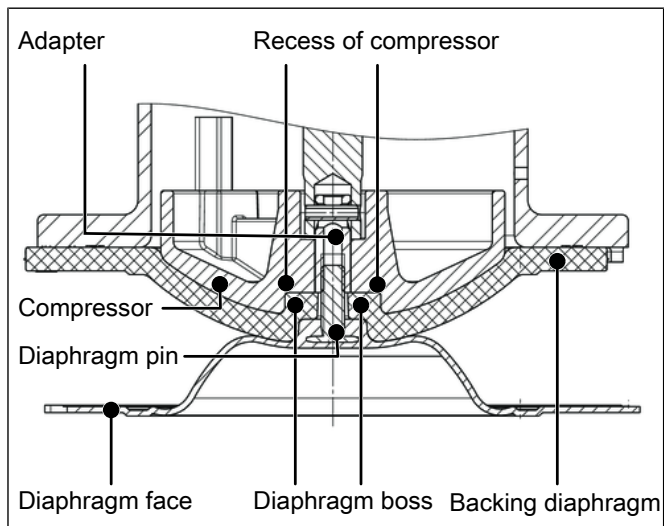
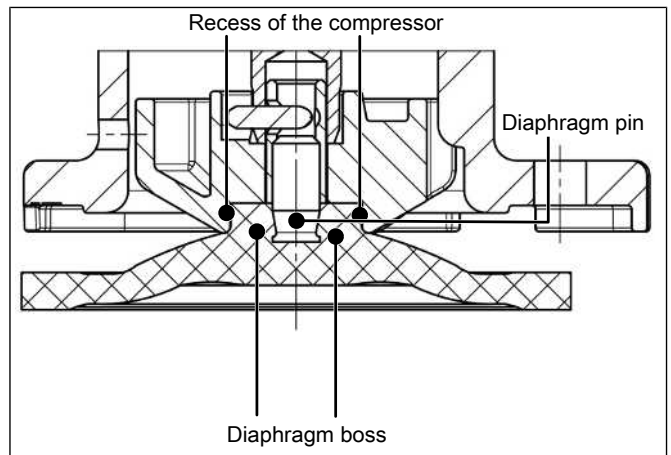

Fig. 15: Screwing in the diaphragm face

1. Move the actuator **A** to the closed position.
2. Mount the compressor (see "Mounting the compressor").
3. Check if the compressor is fitted in the guides.
4. Invert the new diaphragm face manually (use a clean, padded mat with larger nominal sizes).
5. Position the new backing diaphragm onto the compressor.
6. Position the diaphragm face onto the backing diaphragm.
7. Screw diaphragm face tightly into the compressor manually.
 - ⇒ The diaphragm boss must fit closely in the recess of the compressor.
8. If it is difficult to screw it in, check the thread and replace damaged parts.
9. When definitive resistance is felt, turn back the diaphragm until its bolt holes are in correct alignment with the bolt holes of the actuator.
10. Press the diaphragm face tightly onto the backing diaphragm manually so that it returns to its original shape and fits closely on the backing diaphragm.
11. Align the weir of compressor and diaphragm in parallel.

18.5.2 Mounting the concave diaphragm



1. Move the actuator **A** to the closed position.
2. Mount the compressor (see "Mounting the compressor").
3. Check if the compressor is fitted in the guides.
4. Manually screw new diaphragm tightly into the compressor.
5. Check if the diaphragm boss fits closely in the recess of the compressor.
6. If it is difficult to screw it in, check the thread and replace damaged parts.
7. When definitive resistance is felt, turn back the diaphragm until its bolt holes are in correct alignment with the bolt holes of the actuator.
8. Align the weir of compressor and diaphragm in parallel.

18.6 Mounting the actuator

NOTICE

Diaphragms set in the course of time.

- ▶ Leakage
- After disassembly/assembly of the product, check that the bolts and nuts on the body are tight and retighten if required.
- Retighten the bolts and nuts at the very latest after the first sterilization process.

1. Move the actuator **A** to the open position.
2. Place actuator **A** with the mounted diaphragm on valve body **1**.
 - ⇒ Take care that the diaphragm is in the correct orientation.
3. Screw in bolts, washers and nuts hand tight.
 - ⇒ Fastening elements may vary depending on the diaphragm size and/or valve body version.
4. Move the actuator **A** to the closed position.
5. Open actuator **A** approx. 20%.
6. Fully tighten the bolts with nuts diagonally.

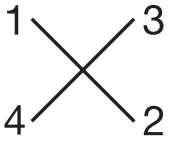

7. Ensure even compression of the diaphragm (approx. 10 to 15%).
 - ⇒ Even compression is detected by an even bulge to the outside.
 - Please note:** For a code 5M diaphragm (convex diaphragm), the PTFE diaphragm face and the EPDM backing diaphragm must be positioned level with and parallel to the valve body.
8. With the valve fully assembled, check the function and tightness.
9. Carry out initialisation.

19 Error messages

19.1 LED error messages

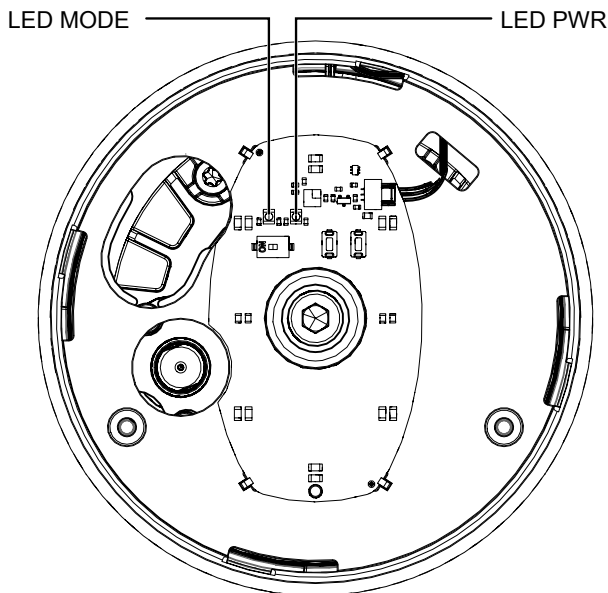

Function	LED MODE		LED PWR	
	yellow	blue	green	red
Undervoltage (no error display of the high visibility LED)				
Internal error				
	alternating			alternating
Calibration faulty				
	simultaneously			simultaneously
Initialization failure				
Temperature error (overtemperature)				
Set value error (< 4 mA, > 20 mA)				
Actual value error (< 4 mA, > 20 mA)				

Fig. 16: Position of the status LEDs

The user checks the following conditions directly on-site at the valve using LED MODE and LED PWR:

Function	High visibility LED	
	green	orange
Error / Error display		

19.2 Troubleshooting

Error	Possible cause	Troubleshooting
The product is leaking downstream (does not close or does not close fully)	Operating pressure too high	Operate the product with operating pressure specified in datasheet
	Foreign matter between shut-off diaphragm and valve body	Remove the actuator, remove foreign matter, check diaphragm and valve body for potential damage, replace damaged parts if necessary
	Shut-off diaphragm faulty	Check shut-off diaphragm for potential damage, replace the shut off diaphragm if necessary
The product is leaking in the passage (does not close or does not close completely).	Valve body leaking or damaged	Carry out initialisation, check valve body for damage, replace valve body if necessary.
The product does not close or does not close fully	The actuator design is not suitable for the operating conditions	Use an actuator that is designed for the operating conditions
	Foreign matter in the product	Remove and clean the product
	Voltage is not connected	Connect voltage
	Electrical connection faulty	Check electrical connection and correct if necessary
The product does not open or does not open fully	Actuator defective	Replace the actuator
	Shut-off diaphragm incorrectly mounted	Remove the actuator, check the diaphragm mounting, replace the shut-off diaphragm if necessary
	Operating pressure too high	Operate the product with operating pressure specified in datasheet
	Foreign matter in the product	Remove and clean the product
	The actuator design is not suitable for the operating conditions	Use an actuator that is designed for the operating conditions
	Voltage is not connected	Connect voltage
	Cable ends incorrectly wired	Wire cable ends correctly
The product is leaking between actuator and valve body	Shut-off diaphragm incorrectly mounted	Remove the actuator, check the diaphragm mounting, replace the shut-off diaphragm if necessary
	Bolting between valve body and actuator loose	Tighten bolting between valve body and actuator
	Shut-off diaphragm faulty	Check shut-off diaphragm for potential damage, replace the shut-off diaphragm if necessary
	Actuator/valve body damaged	Replace actuator/valve body
The product is leaking between actuator flange and valve body	Mounting parts loose	Retighten mounting parts
Valve body of the GEMÜ product is leaking	Valve body of the GEMÜ product is faulty or corroded	Check valve body of the GEMÜ product for potential damage, replace valve body if necessary
Valve body connection to piping leaking	Incorrect installation	Check installation of valve body in piping
LED 1 is not lit	No initialisation	Initialise valve
	Supply voltage too low	Check supply voltage
LED 1 lights up yellow	Set value signal outside of the area	Check set value signal
	Temperature error	Check temperature
LED 1 flashes yellow	Actual value signal outside of the area	Check actual value signal

Error	Possible cause	Troubleshooting
LED 1 and 2 are flashing yellow and red simultaneously	No calibration	Contact GEMÜ
	Internal error	Contact GEMÜ

20 Disposal

1. Pay attention to adhered residual material and gas diffusion from penetrated media.
2. Dispose of all parts in accordance with the disposal regulations/environmental protection laws.

21 Returns

Legal regulations for the protection of the environment and personnel require that the completed and signed return delivery note is included with the dispatch documents. Returned goods can be processed only when this note is completed. If no return delivery note is included with the product, GEMÜ cannot process credits or repair work but will dispose of the goods at the operator's expense.

1. Clean the product.
2. Request a return delivery note from GEMÜ.
3. Complete the return delivery note.
4. Send the product with a completed return delivery note to GEMÜ.

22 EU Declaration of Incorporation according to the EC Machinery Directive 2006/42/EC, Annex II B



EU Declaration of Incorporation

according to the EC Machinery Directive 2006/42/EC, Annex II B

We, the company GEMÜ Gebr. Müller Apparatebau GmbH & Co. KG
Fritz-Müller-Strasse 6-8
74653 Ingelfingen-Criesbach, Germany

hereby declare under our sole responsibility that the below-mentioned product complies with the relevant essential health and safety requirements in accordance with Annex I of the above-mentioned Directive.

Product: GEMÜ 649
Product name: Motorized diaphragm valve
The following essential health and safety requirements of the EC Machinery Directive 2006/42/EC, Annex I have been applied or adhered to: 1.1.2.; 1.1.3.; 1.1.5.; 1.3.2.; 1.3.4.; 1.3.7.; 1.3.8.; 1.5.1.; 1.5.13.; 1.5.2.; 1.5.4.; 1.5.6.; 1.5.7.; 1.5.8.; 1.6.1.; 1.6.3.; 1.6.5.; 1.7.1.; 1.7.1.1.; 1.7.2.; 1.7.3.; 1.7.4.; 1.7.4.1.; 1.7.4.2.; 1.7.4.3.
The following harmonized standards (or parts thereof) have been applied: EN ISO 12100:2010

We also declare that the specific technical documents have been created in accordance with part B of Annex VII.

The manufacturer undertakes to transmit relevant technical documents on the partly completed machinery to the national authorities in response to a reasoned request. This communication takes place electronically.

This does not affect the industrial property rights.

The partly completed machinery may be commissioned only if it has been determined, if necessary, that the machinery into which the partly completed machinery is to be installed meets the provisions of the Machinery Directive 2006/42/EC.

M. Barghoorn
Head of Global Technics

Ingelfingen, 16/06/2023

GEMÜ Gebr. Müller Apparatebau GmbH & Co. KG
Fritz-Müller-Straße 6-8 D-74653 Ingelfingen-Criesbach

www.gemu-group.com
info@gemu.de

23 EU Declaration of Conformity in accordance with 2014/30/EU (EMC Directive)



EU Declaration of Conformity
in accordance with 2014/30/EU (EMC Directive)

We, the company GEMÜ Gebr. Müller Apparatebau GmbH & Co. KG
Fritz-Müller-Strasse 6-8
74653 Ingelfingen-Criesbach, Germany

hereby declare under our sole responsibility that the below-mentioned product complies with the regulations of the above-mentioned Directive.

Product: GEMÜ 649
Product name: Motorized diaphragm valve
The following harmonized standards (or parts thereof) have been applied: EN 61800-3:2004/A1:2012; EN 61000-6-2:2005/AC:2005 (valid for all types)
EN 61326-1:2013; EN 61000-6-4:2007/A1:2011 (only valid for Actuator size 1 / Actuator size 0)

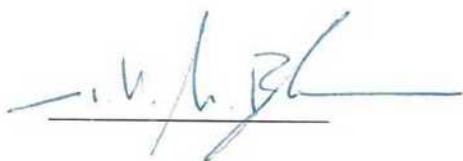

M. Barghoorn
Head of Global Technics
Ingelfingen, 16/06/2023

24 EU Declaration of Conformity in accordance with 2014/68/EU (Pressure Equipment Directive)



EU Declaration of Conformity

in accordance with 2014/68/EU (Pressure Equipment Directive)

We, the company
GEMÜ Gebr. Müller Apparatebau GmbH & Co. KG
Fritz-Müller-Strasse 6-8
74653 Ingelfingen-Criesbach, Germany

hereby declare under our sole responsibility that the below-mentioned product complies with the regulations of the above-mentioned Directive.

Product: GEMÜ 649
Product name: Motorized diaphragm valve
Notified body: TÜV Rheinland Industrie Service GmbH
Am Grauen Stein 1
51105 Cologne, Germany

ID number of the notified body: 0035
No. of the QA certificate: 01 202 926/Q-02 0036
Conformity assessment procedure: Module H1

The following harmonized standards (or parts thereof) have been applied: EN 13397:2001

Information for products with a nominal size \leq DN 25:

The products are developed and produced according to GEMÜ's in-house process instructions and standards of quality which comply with the requirements of ISO 9001 and ISO 14001. According to Article 4, Paragraph 3 of the Pressure Equipment Directive 2014/68/EU, these products must not be identified by a CE-marking.

Other applied technical standards / Remarks:

- AD 2000

M. Barghoorn
Head of Global Technics
Ingelfingen, 16/06/2023

GEMÜ Gebr. Müller Apparatebau GmbH & Co. KG
Fritz-Müller-Straße 6-8 D-74653 Ingelfingen-Criesbach

www.gemu-group.com
info@gemu.de

25 EU Declaration of Conformity In accordance with 2011/65/EU (RoHS Directive)



EU Declaration of Conformity
In accordance with 2011/65/EU (RoHS Directive)

We, the company GEMÜ Gebr. Müller Apparatebau GmbH & Co. KG
Fritz-Müller-Strasse 6-8
74653 Ingelfingen-Criesbach, Germany

hereby declare under our sole responsibility that the below-mentioned product complies with the regulations of the above-mentioned Directive.

Product: GEMÜ 649
Product name: Motorized diaphragm valve
The following harmonized standards (or parts thereof) have been applied: EN IEC 63000:2018

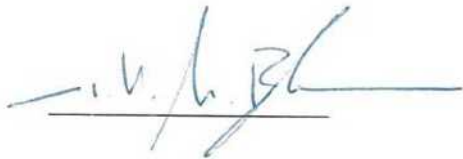

M. Barghoorn
Head of Global Technics
Ingelfingen, 16/06/2023



GEMÜ Gebr. Müller Apparatebau GmbH & Co. KG
Fritz-Müller-Straße 6-8, 74653 Ingelfingen-Criesbach, Germany
Phone +49 (0) 7940 1230 · info@gemue.de
www.gemu-group.com

Subject to alteration

05.2024 | 88614490