

GEMÜ 717

Manually operated ball valve

EN

Operating instructions



All rights including copyrights or industrial property rights are expressly reserved.

Keep the document for future reference.

© GEMÜ Gebr. Müller Apparatebau GmbH & Co. KG
05.07.2023

Contents

1	General information	4
1.1	Information	4
1.2	Symbols used	4
1.3	Definition of terms	4
1.4	Warning notes	4
2	Safety information	4
3	Product description	5
3.1	Construction	5
3.2	Description	5
3.3	Function	5
3.4	Port positions	6
3.5	Product label	6
4	Correct use	7
5	Order data	8
6	Technical data	10
6.1	Medium	10
6.2	Temperature	10
6.4	Mechanical data	11
7	Dimensions	13
7.2	2/2-way body	13
7.3	Multi-port design	20
8	Manufacturer's information	24
8.1	Delivery	24
8.2	Packaging	24
8.3	Transport	24
8.4	Storage	24
9	Installation in piping	24
9.1	Preparing for installation	24
9.2	Installation with inserts for solvent cementing	25
9.3	Installation with inserts for welding	26
9.4	Installation with screw-type inserts	26
9.5	Installation with flanged connection	27
10	Electrical connection of electrical position indicators (optional accessories)	27
10.1	Connection diagrams	27
11	Commissioning	28
12	Operation	28
12.1	Handle	28
12.2	Hand lever	29
12.3	Threaded connection locking devices	29
13	Troubleshooting	31
14	Inspection and maintenance	32
14.1	Spare parts	33
14.2	Replacement of spare parts	36
15	Removal from piping	37
16	Returns	37
17	EU Declaration of conformity 2-way ball valve	38
18	EU Declaration of conformity 3-way ball valve	39

1 General information

1.1 Information

- The descriptions and instructions apply to the standard versions. For special versions not described in this document the basic information contained herein applies in combination with any additional special documentation.
- Correct installation, operation, maintenance and repair work ensure faultless operation of the product.
- Should there be any doubts or misunderstandings, the German version is the authoritative document.
- Contact us at the address on the last page for staff training information.

1.2 Symbols used

The following symbols are used in this document:

Symbol	Meaning
●	Tasks to be performed
▶	Response(s) to tasks
–	Lists

1.3 Definition of terms

Working medium

The medium that flows through the GEMÜ product.



1.4 Warning notes



Wherever possible, warning notes are organised according to the following scheme:

SIGNAL WORD	
Possible symbol for the specific danger	Type and source of the danger <ul style="list-style-type: none"> ▶ Possible consequences of non-observance. ● Measures for avoiding danger.

Warning notes are always marked with a signal word and sometimes also with a symbol for the specific danger.



The following signal words and danger levels are used:

 DANGER	
	Imminent danger! <ul style="list-style-type: none"> ▶ Non-observance can cause death or severe injury.
 WARNING	
	Potentially dangerous situation! <ul style="list-style-type: none"> ▶ Non-observance can cause death or severe injury.

 CAUTION	
	Potentially dangerous situation! <ul style="list-style-type: none"> ▶ Non-observance can cause moderate to light injury.

NOTICE	
	Potentially dangerous situation! <ul style="list-style-type: none"> ▶ Non-observance can cause damage to property.

The following symbols for the specific dangers can be used within a warning note:

Symbol	Meaning
	Danger of explosion!
	Corrosive chemicals!
	Hot plant components!

2 Safety information

The safety information in this document refers only to an individual product. Potentially dangerous conditions can arise in combination with other plant components, which need to be considered on the basis of a risk analysis. The operator is responsible for the production of the risk analysis and for compliance with the resulting precautionary measures and regional safety regulations.

The document contains fundamental safety information that must be observed during commissioning, operation and maintenance. Non-compliance with these instructions may cause:

- Personal hazard due to electrical, mechanical and chemical effects.
- Hazard to nearby equipment.
- Failure of important functions.
- Hazard to the environment due to the leakage of dangerous substances.

The safety information does not take into account:

- Unexpected incidents and events, which may occur during installation, operation and maintenance.
- Local safety regulations which must be adhered to by the operator and by any additional installation personnel.

Prior to commissioning:

1. Transport and store the product correctly.
2. Do not paint the bolts and plastic parts of the product.
3. Carry out installation and commissioning using trained personnel.
4. Provide adequate training for installation and operating personnel.
5. Ensure that the contents of the document have been fully understood by the responsible personnel.
6. Define the areas of responsibility.
7. Observe the safety data sheets.
8. Observe the safety regulations for the media used.

During operation:

9. Keep this document available at the place of use.
10. Observe the safety information.
11. Operate the product in accordance with this document.
12. Operate the product in accordance with the specifications.
13. Maintain the product correctly.
14. Do not carry out any maintenance work and repairs not described in this document without consulting the manufacturer first.

In cases of uncertainty:

15. Consult the nearest GEMÜ sales office.

3 Product description**3.1 Construction**

Item	Name	Materials
1	Ball valve body	PVC-U, PVC-C, ABS, PP-H or PVDF
2	Pipe connections	PVC-U, PVC-C, ABS, PP-H or PVDF
3	Anti-twist protection	POM
4	Hand lever	HIPVC
	Ball valve seals	FPM, EPDM
	Ball valve seat seals	PTFE

3.2 Description

The GEMÜ 717 2/2 or 3/2-way plastic ball valve has an ergonomically designed hand lever and is manually operated. The seat seal is made from PTFE and the O-ring seals can be made from either EPDM or FKM.

3.3 Function

The product is a 2/2 or 3/2-way plastic ball valve equipped with a plastic manual actuator. The threaded connection locking device enables the unions to be locked in place.

The valve body and the seal material are available in various designs as shown in the datasheet. Optional accessories are available on request (see chapter "Accessories").

3.4 Port positions

3.4.1 T-port

	CLOSED end position	OPEN end position	Condition as supplied to customer OPEN
Delivery condition			
Code T			
Optional port positions, can be user adjusted			
Code 2			
Code 3			
Code 4			

3.4.2 L-port

	CLOSED end position	OPEN end position	Condition as supplied to customer OPEN
Delivery condition			
Code L			
Optional port positions, can be user adjusted			
Code 6			

3.4.3 Control ball

	View with a scale	Control ball
Code R		

View with a scale	Control ball
For 0° - 90° control range, linear control characteristic between port position and percentage flow rate.	
For ball configuration (R), an indicator plate is fitted on the ball valve body.	
NOTE: Ball configuration (R) cannot be retrofitted to standard 2/2-way bodies at a later date.	

3.5 Product label

The product label is located on the actuator. Product label data (example):

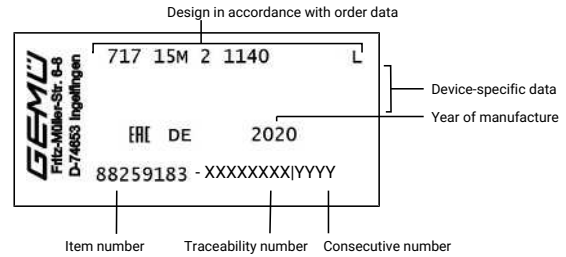

The month of manufacture is encoded in the traceability number and can be obtained from GEMÜ. The product was manufactured in Germany.

The operating pressure stated on the product label applies to a media temperature of 20 °C. The product can be used up to the maximum stated media temperature. You can find the pressure/temperature correlation in the technical data.

4 Correct use

DANGER



Danger of explosion!

- ▶ Risk of death or severe injury
- Do **not** use the product in potentially explosive zones.

WARNING

Improper use of the product!

- ▶ Risk of severe injury or death
- ▶ Manufacturer liability and guarantee will be void
- Only use the product in accordance with the operating conditions specified in the contract documentation and in this document.

The product is designed for installation in piping systems and for controlling a working medium.

The product is not intended for use in potentially explosive areas.

The product is controlled via a manual actuator.

- Use the product in accordance with the technical data.

5 Order data

The order data provide an overview of standard configurations.

Please check the availability before ordering. Other configurations available on request.

Order codes

1 Type	Code
Ball valve, plastic, manually operated	717
2 DN	Code
DN 10	10
DN 15	15
DN 20	20
DN 25	25
DN 32	32
DN 40	40
DN 50	50
DN 65	65
DN 80	80
DN 100	100
3 Body configuration	Code
2/2-way body	D
Multi-port version	M
4 Connection type	Code
Union end with insert (solvent cement or weld socket) - DIN	2
Union end with flange EN 1092, PN 10, form B, face-to-face dimension FTF EN 558 series 1, ISO 5752, basic series 1	4
Union end with inch insert - BS (socket)	33
Union end with flange ANSI Class 125/150 RF	39
Union end with inch insert - ASTM (socket)	3M
Union end with JIS insert (socket)	3T
Union end with insert (for IR butt welding) - DIN	78
Union end with insert (Rp threaded socket) - DIN	7R
Threaded socket NPT	31
5 Ball valve material	Code
PVC-U, grey	1
PVC-C	2
PVDF	20
ABS	4
PP-H, grey	5
6 Seal material	Code
FKM	4
EPDM	14
7 Control function	Code
Manually operated	0
Manually operated, hand lever, lockable	L

8 Ball config./port position	Code
2/2-way body	
R ball (control ball) for 0°- 90° control range linear control characteristic between port position and percentage flow rate	R
Multi-port version	
L-port, standard end position "Open", connection 2 and 3 open, L-port, standard end position "Closed", connection 1 and 3 open	L
T-port, standard end position "Open", connection 1, 2 and 3 open, T-port, standard end position "Closed", connection 1 and 3 open	T
T-port, end position "Open", connection 1 and 3 open, T-port, end position "Closed", connection 1 and 2 open	2
T-port, end position "Open", connection 1 and 2 open, T-port, end position "Closed", connection 2 and 3 open	3
T-port, end position "Open", connection 2 and 3 open, T-port, end position "Closed", connection 1, 2 and 3 open	4
L-port, end position "Open", connection 1 and 3 open, L-port, end position "Closed", connection 1 open	6
9 Type of design	Code
Without	
Insert in PE	1187

Order example

Ordering option	Code	Description
1 Type	717	Ball valve, plastic, manually operated
2 DN	15	DN 15
3 Body configuration	M	Multi-port version
4 Connection type	33	Union end with inch insert - BS (socket)
5 Ball valve material	1	PVC-U, grey
6 Seal material	14	EPDM
7 Control function	0	Manually operated
8 Ball config./port position	L	L-port, standard end position "Open", connection 2 and 3 open, L-port, standard end position "Closed", connection 1 and 3 open
9 Type of design		Without

6 Technical data

6.1 Medium

Working medium: Corrosive, inert, gaseous and liquid media and steam which have no negative impact on the physical and chemical properties of the body and seal material.

6.2 Temperature

Media temperature: see Pressure / temperature diagram

Seal material: FPM: -15 – 210 °C
EPDM: -20 – 95 °C

Ambient temperature: Valve body ABS: -20 to 60 °C
Valve body PP-H: 5 to 60 °C
Valve body PVC-U, PVC-C: 10 to 50 °C
Valve body PVDF: -5 to 50 °C

6.3 Pressure

Operating pressure: Pressure / temperature diagram

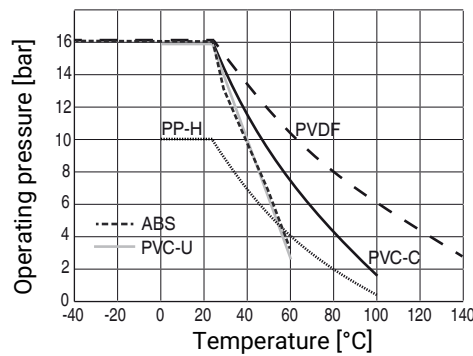

Data for extended temperature ranges on request. Please note that the ambient temperature and media temperature generate a combined temperature at the valve body which must not exceed the above values.

Kv values:

DN	Body configuration						
	2/2-way		Multi-port (code M)				
	(code D)	(code R)	T-port	T-port	T-port	T-port	L-port
10	4.8	4.98	2.2	1.5	2.4	4.7	2.9
15	12.0	5.28	3.3	2.1	3.9	11.7	4.4
20	23.1	8.10	8.1	5.7	8.7	22.8	9.0
25	46.2	15.36	12.3	8.4	14.7	45.6	15.9
32	66.0	28.68	23.4	16.2	27.6	63.0	28.5
40	105.0	35.52	28.5	19.8	36.0	102.0	37.2
50	204.0	64.08	54.0	37.2	72.0	192.0	73.2
65	315.0	-	-	-	-	-	-
80	426.0	-	-	-	-	-	-
100	570.0	-	-	-	-	-	-

Kv values in m³/h

Control diagram: with control ball (code R)

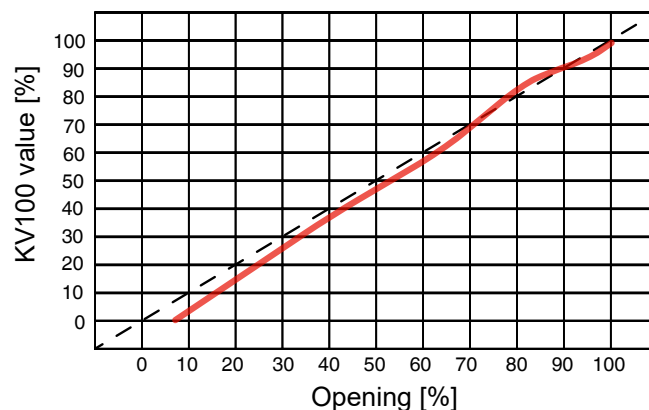

For 0°- 90° control range, linear control characteristic between port position and percentage flow rate.

NOTE: Ball configuration (R) cannot be retrofitted to standard 2/2-way bodies at a later date.

6.4 Mechanical data

Torques:

DN	2/2-way code D				Multi-port code M		
	Optional	Standard		Optional	Optional	Standard	
	PS 6	PS 10	PS 16	PS 16	PS 10	PS 10	PS 16
	Material code ¹⁾						
	1, 2, 4, 5, 20	5	1, 2, 20	4	1, 2	5	1, 2
10	-	2.4	3.6	3.0	-	-	-
15	-	2.4	3.6	3.0	2.4	2.4	3.6
20	-	3.6	4.0	4.0	3.6	3.6	4.8
25	-	4.8	6.0	6.0	5.0	5.0	5.4
32	-	7.2	7.2	7.2	7.2	7.2	11.5
40	-	8.6	10.0	10.0	9.6	10.0	14.8
50	-	12.4	16.0	16.0	14.8	14.8	23.3
65	20.0	25.0	30.0	30.0	-	-	-
80	25.0	35.0	45.0	45.0	-	-	-
100	40.0	55.0	65.0	65.0	-	-	-

Torques in Nm

- 1) **Ball valve material**
 Code 1: PVC-U, grey
 Code 2: PVC-C
 Code 4: ABS
 Code 5: PP-H, grey
 Code 20: PVDF

Weight:

DN	Connection (code)									
	2				4				7R, 31	
	Material (code)									
	1	2	5	20	1	2	5	20	1	5
10	215	234	150	291	-	-	-	-	-	-
15	205	223	145	272	375	481	387	547	210	145
20	330	358	218	445	590	663	504	772	335	220
25	438	476	298	584	713	895	697	1024	448	298
32	693	753	480	938	1108	1379	1075	1583	678	488
40	925	1007	682	1242	1485	1761	1346	2024	955	682
50	1577	1717	1166	2187	2347	2741	2060	3219	1667	1181
65	4380	4789	3090	4380	6610	6413	4500	8588	4395	4395
80	7200	7691	5080	7200	9330	9669	6455	12122	7260	7260
100	11141	11931	7725	11141	13815	14697	9090	17949	11100	11100

Weight in g

DN	Connection (code)										
	33	39			3M	3T	78				
	Material (code)										
	1	1	2	5	1	2	1	1*	5	5*	20
10	210	-	-	-	-	-	-	-	-	-	-
15	205	460	481	387	215	234	225	220	220	210	299
20	335	632	663	504	345	375	335	340	340	325	466
25	433	853	895	697	448	487	448	443	443	420	604
32	703	1313	1379	1075	718	780	728	693	693	570	951
40	925	1669	1761	1346	975	1062	1015	945	945	900	1284
50	1647	2577	2741	2060	1712	1864	1727	1607	1607	1500	2229
65	4380	6610	6413	4500	4390	4762	4435	4400	3150	3100	4700
80	7250	9330	9669	6455	7210	7850	7250	7100	5240	5180	7150
100	10995	13815	14697	9090	11065	12222	11580	10800	7970	7800	11300

* Special version 1187

Weight in g

7 Dimensions

7.1 Connection flange

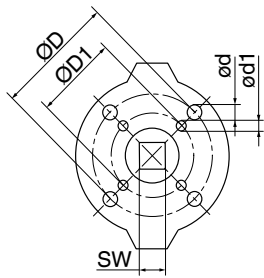

DN 10 - 50

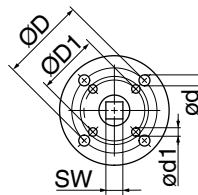
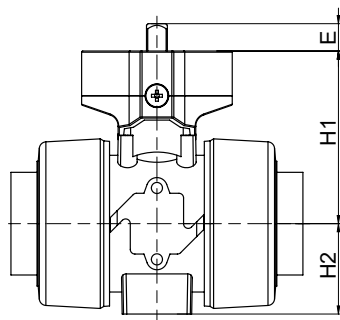

DN 65 - 100

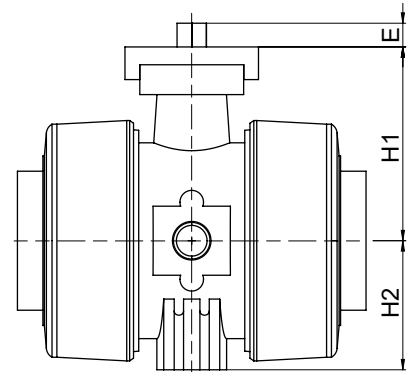

DN	SW	E	H1	H2	ØD x ød	ØD1 x ød1
10	11.0	12.0	58.0	29.0	F03 x 5.5	F04 x 5.5
15	11.0	12.0	58.0	29.0	F03 x 5.5	F04 x 5.5
20	11.0	12.0	69.0	35.0	F03 x 5.5	F05 x 6.5
25	11.0	12.0	74.0	39.0	F03 x 5.5	F05 x 6.5
32	14.0	16.0	91.0	46.0	F05 x 6.5	F07 x 8.5
40	14.0	16.0	78.0	52.0	F05 x 6.5	F07 x 8.5
50	14.0	16.0	114.0	62.0	F05 x 6.5	F07 x 8.5
65	14.0	16.0	131.0	87.0	F07 x 9.0	F05 x 6.5
80	14.0	16.0	131.0	105.0	F07 x 9.0	F05 x 6.5
100	17.0	19.0	149.0	129.0	F07 x 9.0	F05 x 6.5

Dimensions in mm

7.2 2/2-way body

7.2.1 Valve body material PVC-U (code 1), body configuration D

Socket

Connection type code 2, 31, 33, 3M, 3T, 7R

Flange

Connection type code 4, 39

Butt weld spigot

Connection type code 78, 78*

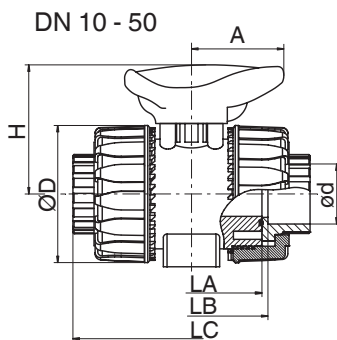

DN 10 - 50

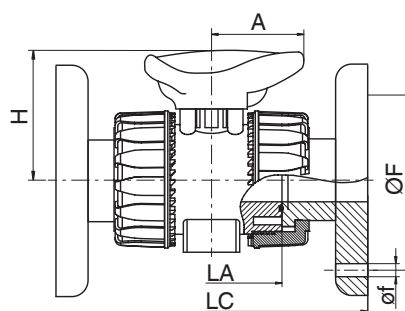

Hand lever DN 65 - 100

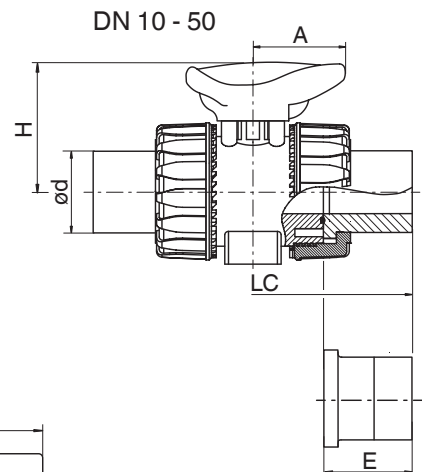
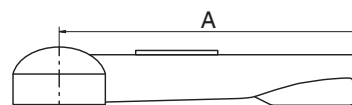

DN 10 - 50

DN	NPS	ød	ØD	A	H	LA	Connection type code ¹⁾							
							4	39	78*	4	39	4	39	78*
							LC			øf		ØF		E
15	1/2"	20.0	54.0	40.0	54.0	65.0	130.0	143.0	175.0	14.0	15.9	65.0	60.3	55.0

DN	NPS	ød	ØD	A	H	LA	Connection type code ¹⁾							
							4	39	78*	4	39	4	39	78*
							LC			øf		ØF		E
20	3/4"	25.0	65.0	49.0	65.0	70.0	150.0	172.0	210.0	14.0	15.9	75.0	69.9	70.0
25	1"	32.0	73.0	49.0	69.5	78.0	160.0	187.0	226.0	14.0	15.9	85.0	79.4	74.0
32	1 ¼"	40.0	86.0	64.0	82.5	88.0	180.0	190.0	243.0	18.0	15.9	100.0	88.9	78.0
40	1 ½"	50.0	98.0	64.0	89.0	93.0	200.0	212.0	261.0	18.0	15.9	110.0	98.4	84.0
50	2"	63.0	122.0	76.0	108.0	111.0	230.0	234.0	293.0	18.0	19.1	125.0	120.7	91.0
65	2 ½"	75.0	164.0	175.0	164.0	133.0	290.0	290.0	356.0	17.0	18.0	145.0	139.7	111.0
80	3"	90.0	203.0	272.0	177.0	149.0	310.0	310.0	390.0	17.0	18.0	160.0	152.4	118.0
100	4"	110.0	238.0	330.0	195.0	167.0	350.0	350.0	431.0	17.0	18.0	180.0	190.5	132.0

Dimensions in mm

* Inserts according to valve body material,
special version: PE insert, design code 1187

1) **Connection type**

Code 4: Union end with flange EN 1092, PN 10, form B, face-to-face dimension FTF EN 558 series 1, ISO 5752, basic series 1

Code 39: Union end with flange ANSI Class 125/150 RF

Code 78: Union end with insert (for IR butt welding) - DIN

7.2.2 Valve body material PVC-U (code 1), body configuration D

Socket

Connection type code 2, 31, 33, 3M, 3T, 7R

Flange

Connection type code 4, 39

Butt weld spigot

Connection type code 78, 78*

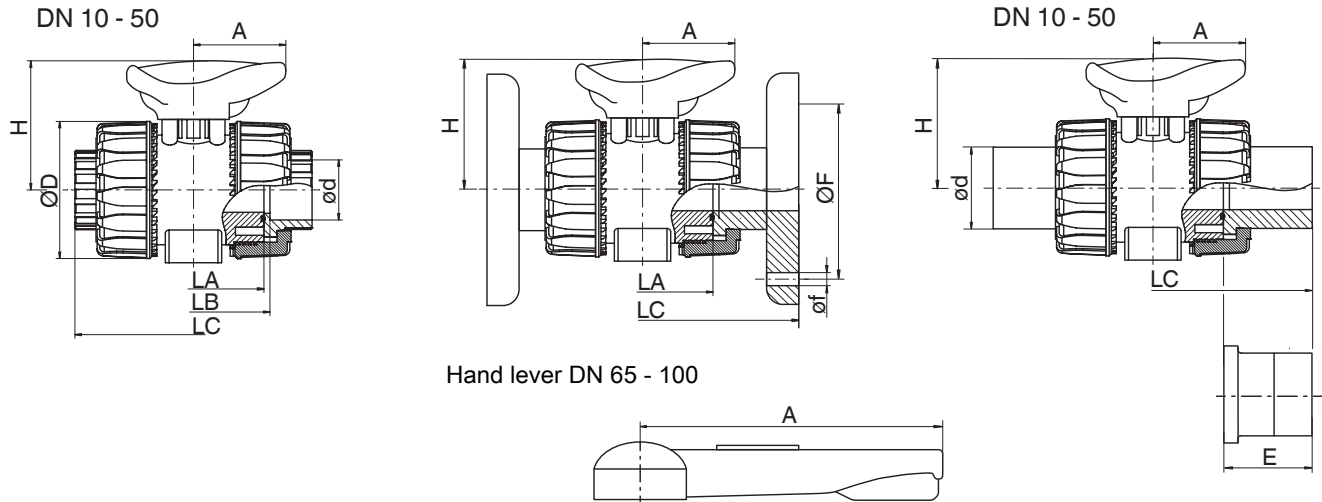

DN	NPS	ød	ØD	A	LA	H	Connection type code ¹⁾										
							3M	2	33	3M	3T	7R	2	33	3M	3T	7R
							ød	LB			LC						
10	3/8"	16.0	54.0	40.0	65.0	54.0	-	75.0	74.0	-	-	-	103.0	103.0	-	-	-
15	1/2"	20.0	54.0	40.0	65.0	54.0	21.5	71.0	70.0	72.0	71.0	80.0	103.0	103.0	117.0	131.0	110.0
20	3/4"	25.0	65.0	49.0	70.0	65.0	26.9	77.0	77.0	78.0	77.0	83.5	115.0	115.0	129.0	147.0	116.0
25	1"	32.0	73.0	49.0	78.0	69.5	33.7	84.0	83.0	84.6	84.0	96.0	128.0	128.0	142.0	164.0	134.0
32	1 1/4"	40.0	86.0	64.0	88.0	82.5	42.4	94.0	94.0	98.0	94.0	110.0	146.0	146.0	162.0	182.0	153.0
40	1 1/2"	50.0	98.0	64.0	93.0	89.0	48.4	102.0	104.0	102.0	102.0	113.0	164.0	164.0	172.0	212.0	156.0
50	2"	63.0	122.0	76.0	111.0	108.0	60.5	123.0	127.0	122.6	122.0	134.5	199.0	199.0	199.0	248.0	186.0
65	2 1/2"	75.0	164.0	175.0	133.0	164.0	75.3	147.0	147.0	146.0	145.0	174.5	235.0	235.0	235.0	267.0	235.0
80	3"	90.0	203.0	272.0	149.0	177.0	89.1	168.0	168.0	174.0	165.0	203.5	270.0	270.0	270.0	294.0	270.0
100	4"	110.0	238.0	330.0	167.0	195.0	114.5	186.0	182.0	193.0	202.0	229.5	308.0	308.0	308.0	370.0	308.0

Dimensions in mm

1) Connection type

Code 2: Union end with insert (solvent cement or weld socket) - DIN

Code 33: Union end with inch insert - BS (socket)

Code 3M: Union end with inch insert - ASTM (socket)

Code 3T: Union end with JIS insert (socket)

Code 7R: Union end with insert (Rp threaded socket) - DIN

7.2.3 Valve body material PVC-C (code 2), body configuration D

Socket

Connection type code 2, 31, 33, 3M, 3T, 7R

Flange

Connection type code 4, 39

Butt weld spigot

Connection type code 78, 78*

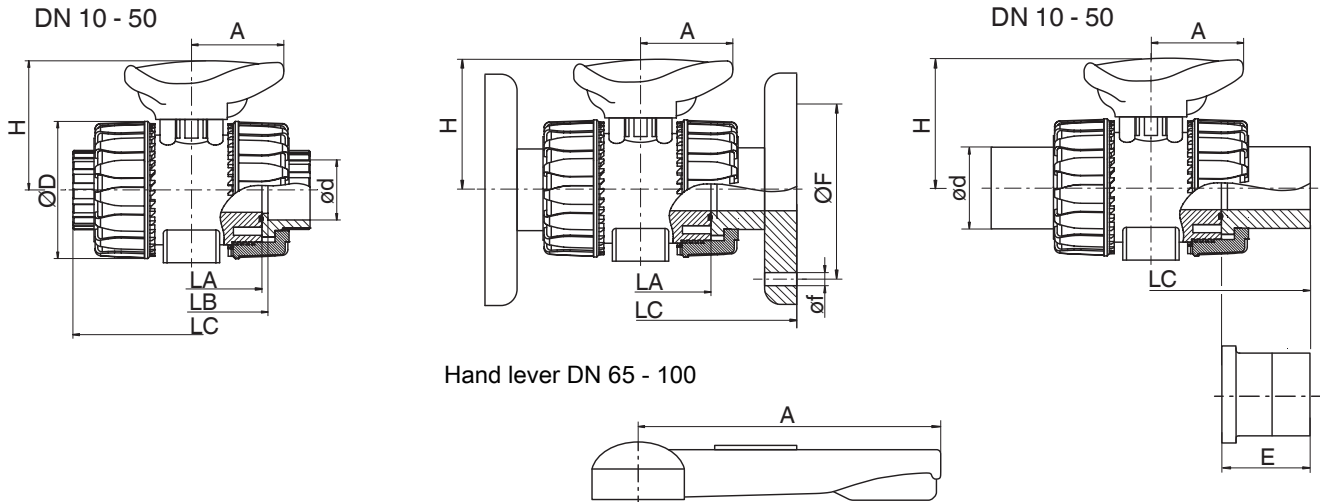

DN	NPS	ød	øD	A	H	LA	Connection type code ¹⁾										
							3M	2	3M	2	4	39	3M	4	39	4	39
							ød	LB		LC		øf		ØF			
10	3/8"	16.0	54.0	40.0	54.0	65.0	-	75.0	-	103.0	-	-	-	-	-	-	-
15	1/2"	20.0	54.0	40.0	54.0	65.0	21.5	71.0	72.0	103.0	130.0	143.0	117.0	14.0	15.9	65.0	60.3
20	3/4"	25.0	65.0	49.0	65.0	70.0	26.9	77.0	78.0	115.0	150.0	172.0	129.0	14.0	15.9	75.0	69.9
25	1"	32.0	73.0	49.0	69.5	78.0	33.7	84.0	84.6	128.0	160.0	187.0	142.0	14.0	15.9	85.0	79.4
32	1 ¼"	40.0	86.0	64.0	82.5	88.0	42.4	94.0	98.0	146.0	180.0	190.0	162.0	18.0	15.9	100.0	88.9
40	1 ½"	50.0	98.0	64.0	89.0	93.0	48.4	102.0	102.0	164.0	200.0	212.0	172.0	18.0	15.9	110.0	98.4
50	2"	63.0	122.0	76.0	108.0	111.0	60.5	123.0	122.6	199.0	230.0	234.0	199.0	18.0	19.1	125.0	120.7
65	2 ½"	75.0	164.0	175.0	164.0	133.0	75.3	147.0	146.0	235.0	290.0	290.0	235.0	17.0	18.0	145.0	139.7
80	3"	90.0	203.0	272.0	177.0	149.0	89.1	168.0	174.0	270.0	310.0	310.0	270.0	17.0	18.0	160.0	152.4
100	4"	110.0	238.0	330.0	195.0	167.0	114.5	186.0	193.0	308.0	350.0	350.0	308.0	17.0	18.0	180.0	190.5

Dimensions in mm

1) **Connection type**

Code 2: Union end with insert (solvent cement or weld socket) - DIN

Code 4: Union end with flange EN 1092, PN 10, form B, face-to-face dimension FTF EN 558 series 1, ISO 5752, basic series 1

Code 39: Union end with flange ANSI Class 125/150 RF

Code 3M: Union end with inch insert – ASTM (socket)

7.2.4 Valve body material ABS (code 4), body configuration D

Socket

Connection type code 2, 31, 33, 3M, 3T, 7R

Flange

Connection type code 4, 39

Butt weld spigot

Connection type code 78, 78*

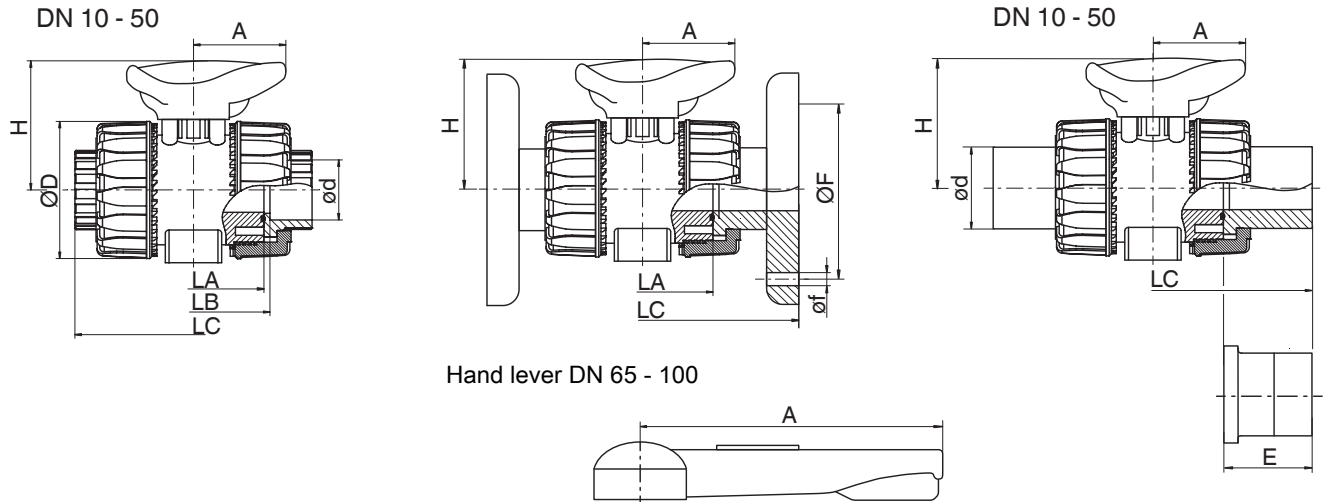

DN	NPS	ød	øD	A	LA	H	Connection type code ¹⁾				
							2	7R	33	2, 33	7R
							LB			LC	
10	3/8"	15.0	55.0	40.0	65.0	49.0	75.0	-	75.0	103.0	-
15	1/2"	20.0	55.0	40.0	65.0	49.0	71.0	80.0	71.0	103.0	110.0
20	3/4"	25.0	66.0	49.0	70.0	59.0	77.0	83.4	77.0	115.0	116.0
25	1"	32.0	75.0	49.0	78.0	66.0	84.0	95.8	84.0	128.0	134.0
32	1 1/4"	40.0	87.0	64.0	88.0	75.0	94.0	110.2	94.0	146.0	153.0
40	1 1/2"	50.0	100.0	64.0	93.0	87.0	102.0	113.2	102.0	164.0	156.0
50	2"	63.0	122.0	76.0	111.0	101.0	123.0	134.6	123.0	199.0	186.0
65	2 1/2"	75.0	164.0	175.0	133.0	164.0	147.0	-	147.0	235.0	-
80	3"	90.0	203.0	272.0	149.0	177.0	168.0	-	168.0	270.0	-
100	4"	110.0	238.0	330.0	167.0	195.0	186.0	-	186.0	308.0	-

Dimensions in mm

1) Connection type

Code 2: Union end with insert (solvent cement or weld socket) - DIN

Code 33: Union end with inch insert - BS (socket)

Code 7R: Union end with insert (Rp threaded socket) - DIN

7.2.5 Valve body material PP-H (code 5), body configuration D

Socket

Connection type code 2, 31, 33, 3M, 3T, 7R

Flange

Connection type code 4, 39

Butt weld spigot

Connection type code 78, 78*

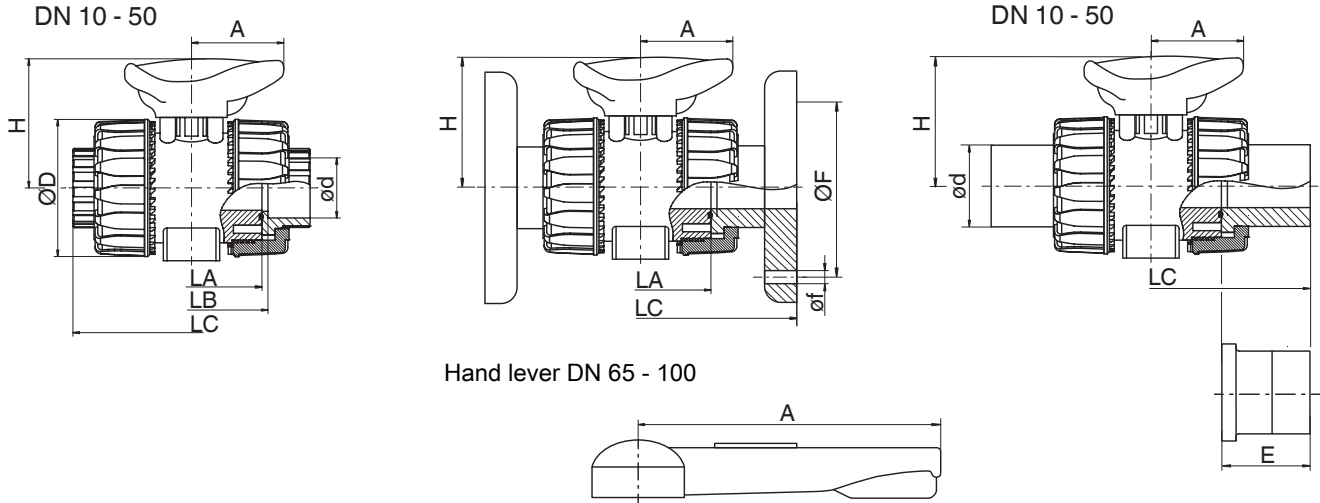

DN	NPS	ød	øD	A	H	LA	Connection type code ¹⁾												
							2	7R	2	4	39	78/78*	7R	78/78*	4	39	4	39	
							LB		LC						E	øf		ØF	
10	3/8"	16.0	54.0	40.0	-	65.0	75.0	-	102.0	-	-	-	-	-	-	-	-	-	-
15	1/2"	20.0	54.0	40.0	54.0	65.0	73.0	80.0	102.0	130.0	143.0	175.0	110.0	55.0	14.0	15.9	65.0	60.3	
20	3/4"	25.0	65.0	49.0	65.0	70.0	82.0	83.0	114.0	150.0	172.0	210.0	116.0	70.0	14.0	15.9	75.0	69.9	
25	1"	32.0	73.0	49.0	69.5	78.0	90.0	96.0	126.0	160.0	187.0	226.0	134.0	77.0	14.0	15.9	85.0	79.4	
32	1 1/4"	40.0	86.0	64.0	82.5	88.0	100.0	110.0	141.0	180.0	190.0	243.0	153.0	78.0	18.0	15.9	100.0	88.9	
40	1 1/2"	50.0	98.0	64.0	89.0	93.0	117.0	113.0	164.0	200.0	212.0	261.0	156.0	84.0	18.0	15.9	110.0	98.4	
50	2"	63.0	122.0	76.0	108.0	111.0	144.0	134.0	199.0	230.0	234.0	293.0	186.0	91.0	18.0	15.9	125.0	120.7	
65	2 1/2"	75.0	164.0	175.0	164.0	133.0	153.0	-	213.0	290.0	290.0	356.0	-	111.0	17.0	18.0	145.0	139.7	
80	3"	90.0	203.0	272.0	177.0	149.0	173.0	-	239.0	310.0	310.0	390.0	-	118.0	17.0	18.0	160.0	152.4	
100	4"	110.0	238.0	330.0	195.0	167.0	199.0	-	268.0	350.0	350.0	431.0	-	132.0	17.0	18.0	180.0	190.5	

Dimensions in mm

* Inserts according to valve body material, special version: PE insert, design code 1187

1) **Connection type**

- Code 2: Union end with insert (solvent cement or weld socket) - DIN
- Code 4: Union end with flange EN 1092, PN 10, form B, face-to-face dimension FTF EN 558 series 1, ISO 5752, basic series 1
- Code 39: Union end with flange ANSI Class 125/150 RF
- Code 78: Union end with insert (for IR butt welding) - DIN
- Code 7R: Union end with insert (Rp threaded socket) - DIN

7.2.6 Valve body material PVDF (code 20), body configuration D

Socket

Connection type code 2, 31, 33, 3M, 3T, 7R

Flange

Connection type code 4, 39

Butt weld spigot

Connection type code 78, 78*

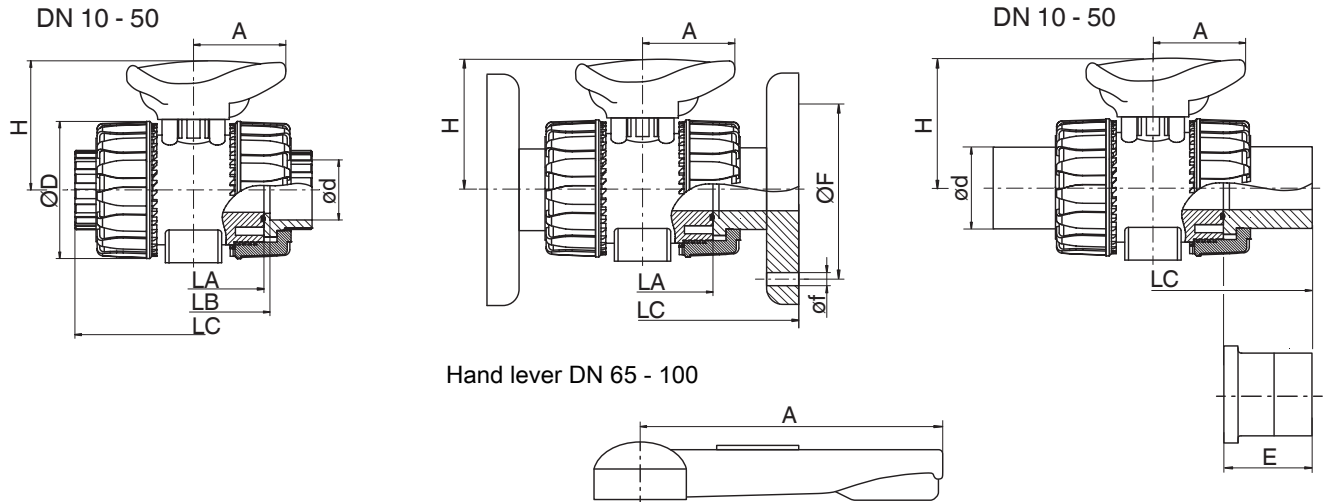

DN	NPS	ød	ØD	A	H	LA	Connection type code ¹⁾								
							2	2	4	78	4	39	4	39	78*
							LB	LC		øf		ØF		E	
10	3/8"	16.0	54.0	40.0	54.0	65.0	74.5	102.0	-	-	-	-	-	-	-
15	1/2"	20.0	54.0	40.0	54.0	65.0	73.0	102.0	130.0	124.0	14.0	15.9	65.0	60.5	30.0
20	3/4"	25.0	65.0	49.0	65.0	70.0	82.0	114.0	150.0	144.0	14.0	15.9	75.0	70.0	37.0
25	1"	32.0	73.0	49.0	69.5	78.0	90.0	126.0	160.0	154.0	14.0	15.9	85.0	79.5	39.5
32	1 1/4"	40.0	86.0	64.0	82.5	88.0	100.0	141.0	180.0	174.0	18.0	15.9	100.0	89.0	44.5
40	1 1/2"	50.0	98.0	64.0	89.0	93.0	117.0	164.0	200.0	194.0	18.0	15.9	110.0	98.5	51.5
50	2"	63.0	122.0	76.0	108.0	111.0	144.0	199.0	230.0	224.0	18.0	19.1	134.0	121.0	58.0
65	2 1/2"	75.0	164.0	175.0	164.0	133.0	147.0	235.0	290.0	355.0	18.0	18.0	145.0	140.0	110.5
80	3"	90.0	203.0	272.0	177.0	149.0	173.0	239.0	310.0	389.0	18.0	18.0	160.0	152.5	118.5
100	4"	110.0	238.0	330.0	195.0	167.0	186.0	308.0	350.0	427.0	18.0	18.0	180.0	190.5	130.5

Dimensions in mm

* Inserts according to valve body material,
special version: PE insert, design code 1187

1) Connection type

Code 2: Union end with insert (solvent cement or weld socket) - DIN

Code 4: Union end with flange EN 1092, PN 10, form B, face-to-face dimension FTF EN 558 series 1, ISO 5752, basic series 1

Code 39: Union end with flange ANSI Class 125/150 RF

Code 78: Union end with insert (for IR butt welding) - DIN

7.3 Multi-port design

7.3.1 Valve body material PVC-U (code 1), body configuration M

Connection type code 2, 33, 3M, 3T, 7R

Connection type code 78, 78*

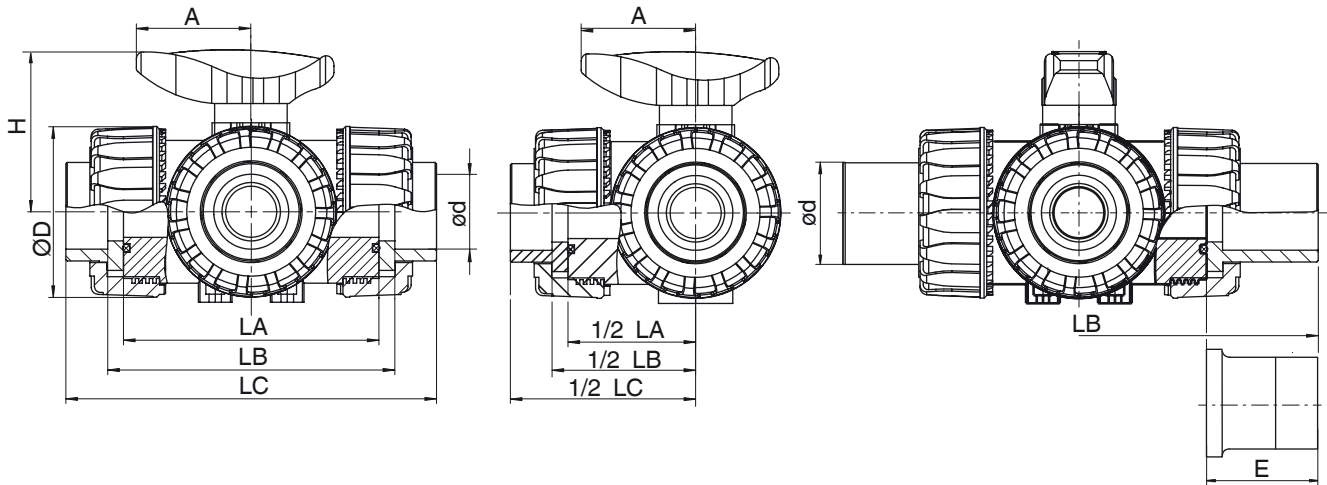

DN	NPS	ød	ØD	A	H	LA	Connection type code ¹⁾											
							3M	2	33	3M	3T	7R	2, 33	3M	3T	7R	78*	78*
							ød	LB							LC	E		
10	3/8"	16.0	54.0	40.0	54.0	80.0	-	90.0	-	-	-	-	118.0	-	-	-	-	-
15	1/2"	20.0	54.0	40.0	54.0	80.0	21.5	86.0	85.0	87.2	86.0	95.0	118.0	132.2	146.0	125.0	190.0	55.0
20	3/4"	25.0	65.0	49.0	65.0	100.0	26.9	107.0	106.8	108.2	107.0	114.0	145.0	159.2	177.0	146.0	240.0	70.0
25	1"	32.0	73.0	49.0	69.5	110.0	33.7	116.0	115.0	116.6	116.0	129.0	160.0	174.0	196.0	166.0	258.0	74.0
32	1 1/4"	40.0	86.0	64.0	82.5	131.0	42.4	136.5	136.6	141.0	137.0	151.0	188.5	205.0	225.0	195.5	287.0	78.0
40	1 1/2"	50.0	98.0	64.0	89.0	148.0	48.4	157.0	159.0	157.6	157.2	166.0	219.0	227.6	267.2	211.0	316.0	84.0
50	2"	63.0	122.0	76.0	108.0	179.0	60.5	190.5	194.2	190.6	190.0	199.0	266.5	267.0	316.0	253.5	361.0	91.0

Dimensions in mm

* Inserts according to valve body material, special version: PE insert, design code 1187

1) **Connection type**

Code 2: Union end with insert (solvent cement or weld socket) - DIN

Code 33: Union end with inch insert - BS (socket)

Code 3M: Union end with inch insert - ASTM (socket)

Code 3T: Union end with JIS insert (socket)

Code 78: Union end with insert (for IR butt welding) - DIN

Code 7R: Union end with insert (Rp threaded socket) - DIN

7.3.2 Valve body material PVC-C (code 2), body configuration M

Connection type code 2, 33, 3M, 3T, 7R

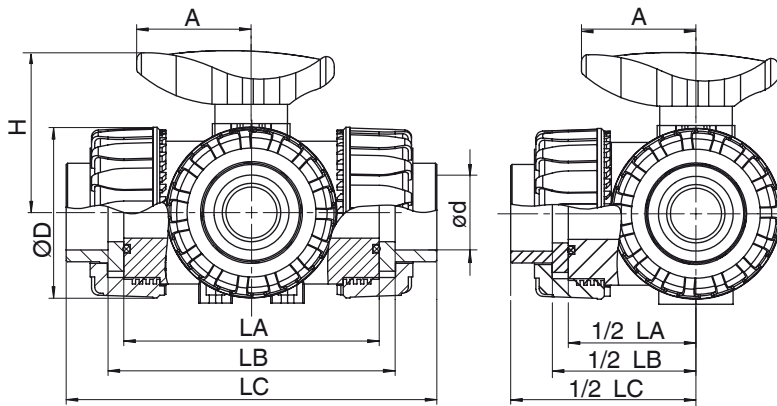

DN	NPS	ØD	A	H	LA	Connection type code ¹⁾					
						2	3M	2	3M	2	3M
						ød		LB		LC	
10	3/8"	54.0	40.0	54.0	80.0	16.0	-	90.0	-	118.0	-
15	1/2"	54.0	40.0	54.0	80.0	20.0	21.5	86.0	87.2	118.0	132.2
20	3/4"	65.0	49.0	65.0	100.0	25.0	26.9	107.0	108.2	145.0	159.2
25	1"	73.0	49.0	69.5	110.0	32.0	33.7	116.0	116.6	160.0	174.0
32	1 1/4"	86.0	64.0	82.5	131.0	40.0	42.4	136.5	141.0	188.5	205.0
40	1 1/2"	98.0	64.0	89.0	148.0	50.0	48.4	157.0	157.6	219.0	227.6
50	2"	122.0	76.0	108.0	179.0	63.0	60.5	190.5	190.6	266.5	267.0

Dimensions in mm

1) Connection type

Code 2: Union end with insert (solvent cement or weld socket) - DIN

Code 3M: Union end with inch insert – ASTM (socket)

7.3.3 Valve body material ABS (code 4), body configuration M

Connection type code 2, 33, 3M, 3T, 7R

Connection type code 78, 78*

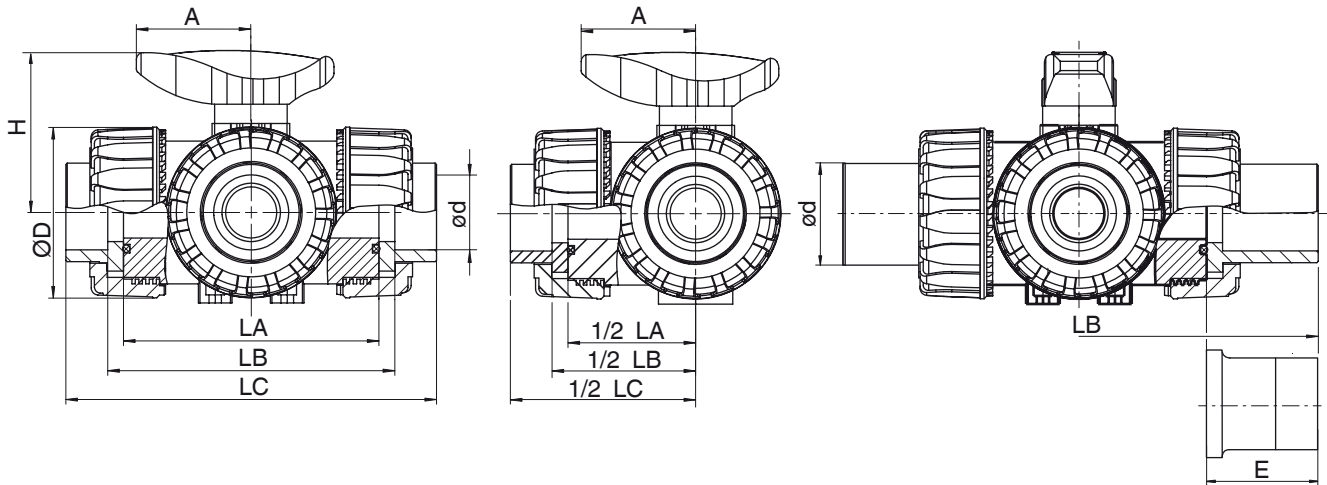

DN	NPS	ød	ØD	A	H	LA	Connection type code ¹⁾											
							3M	2	33	3M	3T	7R	2, 33	3M	3T	7R	78*	78*
							ød	LB					LC					E
10	3/8"	16.0	54.0	40.0	54.0	80.0	-	90.0	-	-	-	-	118.0	-	-	-	-	-
15	1/2"	20.0	54.0	40.0	54.0	80.0	21.5	86.0	85.0	87.2	86.0	95.0	118.0	132.2	146.0	125.0	190.0	55.0
20	3/4"	25.0	65.0	49.0	65.0	100.0	26.9	107.0	106.8	108.2	107.0	114.0	145.0	159.2	177.0	146.0	240.0	70.0
25	1"	32.0	73.0	49.0	69.5	110.0	33.7	116.0	115.0	116.6	116.0	129.0	160.0	174.0	196.0	166.0	258.0	74.0
32	1 ¼"	40.0	86.0	64.0	82.5	131.0	42.4	136.5	136.6	141.0	137.0	151.0	188.5	205.0	225.0	195.5	287.0	78.0
40	1 ½"	50.0	98.0	64.0	89.0	148.0	48.4	157.0	159.0	157.6	157.2	166.0	219.0	227.6	267.2	211.0	316.0	84.0
50	2"	63.0	122.0	76.0	108.0	179.0	60.5	190.5	194.2	190.6	190.0	199.0	266.5	267.0	316.0	253.5	361.0	91.0

Dimensions in mm

* Inserts according to valve body material, special version: PE insert, design code 1187

1) **Connection type**

- Code 2: Union end with insert (solvent cement or weld socket) - DIN
- Code 33: Union end with inch insert - BS (socket)
- Code 3M: Union end with inch insert - ASTM (socket)
- Code 3T: Union end with JIS insert (socket)
- Code 78: Union end with insert (for IR butt welding) - DIN
- Code 7R: Union end with insert (Rp threaded socket) - DIN

7.3.4 Valve body material PP-H (code 5), body configuration M

Connection type code 2, 33, 3M, 3T, 7R

Connection type code 78, 78*

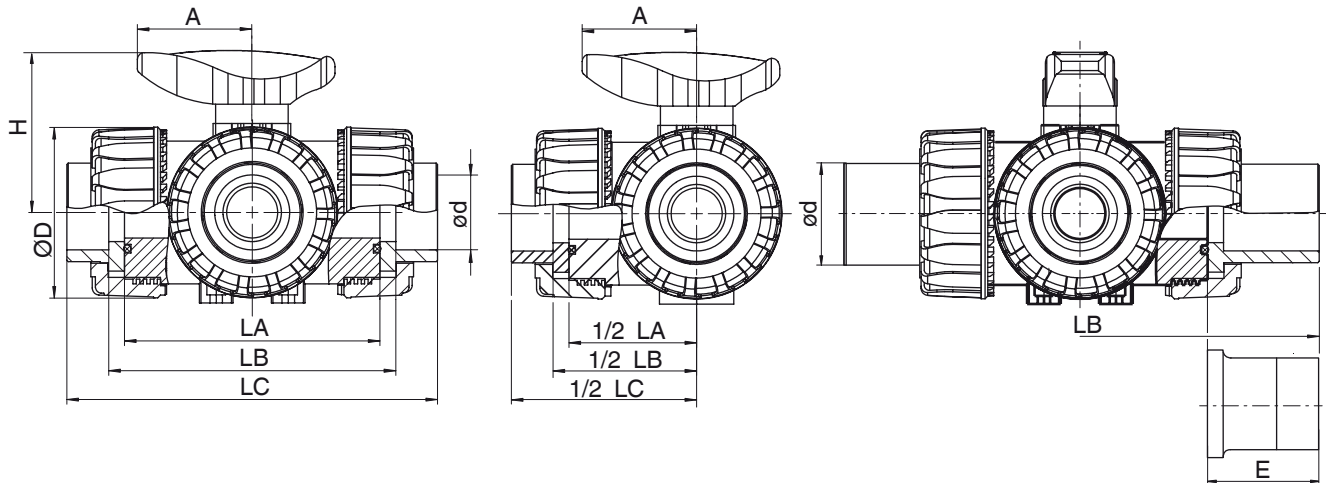

DN	NPS	ød	ØD	A	H	LA	Connection type code ¹⁾					
							2	7R	2	7R	78, 78*	78, 78*
							LB 1		LC		E	
15	1/2"	20.0	54.0	40.0	54.0	80.0	88.0	87.0	117.0	117.0	190.0	55.0
20	3/4"	25.0	65.0	49.0	65.0	100.0	112.0	114.0	144.0	143.0	240.0	70.0
25	1"	32.0	69.5	49.0	69.5	110.0	122.0	120.0	158.0	157.0	258.0	74.0
32	1 1/4"	40.0	82.5	64.0	82.5	131.0	142.5	140.0	183.5	184.5	287.0	78.0
40	1 1/2"	50.0	89.0	64.0	89.0	148.0	172.0	172.0	216.0	217.0	316.0	84.0
50	2"	63.0	108.0	76.0	108.0	179.0	211.5	211.0	266.5	265.5	361.0	91.0

Dimensions in mm

* Inserts according to valve body material,
special version: PE insert, design code 1187

1) Connection type

Code 2: Union end with insert (solvent cement or weld socket) - DIN

Code 78: Union end with insert (for IR butt welding) - DIN

Code 7R: Union end with insert (Rp threaded socket) - DIN

8 Manufacturer's information

8.1 Delivery

- Check that all parts are present and check for any damage immediately upon receipt.

The product's performance is tested at the factory. The scope of delivery is apparent from the dispatch documents and the design from the order number.

8.2 Packaging

The product is packaged in a cardboard box which can be recycled as paper.

8.3 Transport



1. Only transport the product by suitable means. Do not drop. Handle carefully.
2. After the installation dispose of transport packaging material according to relevant local or national disposal regulations / environmental protection laws.

8.4 Storage

1. Store the product free from dust and moisture in its original packaging.
2. Avoid UV rays and direct sunlight.
3. Do not exceed the maximum storage temperature (see chapter "Technical data").
4. Do not store solvents, chemicals, acids, fuels or similar fluids in the same room as GEMÜ products and their spare parts.

9 Installation in piping

9.1 Preparing for installation

⚠ WARNING	
The equipment is subject to pressure!	
<ul style="list-style-type: none"> ▶ Risk of severe injury or death ● Depressurize the plant. ● Completely drain the plant. 	
⚠ WARNING	
	Corrosive chemicals!
<ul style="list-style-type: none"> ▶ Risk of caustic burns ● Wear appropriate protective gear. ● Completely drain the plant. 	
⚠ CAUTION	
	Hot plant components!
<ul style="list-style-type: none"> ▶ Risk of burns ● Only work on plant that has cooled down. 	
⚠ CAUTION	
Exceeding the maximum permissible pressure.	
<ul style="list-style-type: none"> ▶ Damage to the product ● Provide precautionary measures against exceeding the maximum permitted pressures caused by pressure surges (water hammer). 	
⚠ CAUTION	
Use as step.	
<ul style="list-style-type: none"> ▶ Damage to the product ▶ Risk of slipping-off ● Choose the installation location so that the product cannot be used as a foothold. ● Do not use the product as a step or a foothold. 	
NOTICE	
Suitability of the product!	
<ul style="list-style-type: none"> ▶ The product must be appropriate for the piping system operating conditions (medium, medium concentration, temperature and pressure) and the prevailing ambient conditions. 	

NOTICE**Tools**

- ▶ The tools required for installation and assembly are not included in the scope of delivery.
- Use appropriate, functional and safe tools.

1. Ensure the product is suitable for the relevant application.
2. Check the technical data of the product and the materials.
3. Keep appropriate tools ready.
4. Wear appropriate protective gear, as specified in the plant operator's guidelines.
5. Observe appropriate regulations for connections.
6. Have installation work carried out by trained personnel.
7. Shut off plant or plant component.
8. Secure plant or plant component against recommissioning.
9. Depressurize the plant or plant component.
10. Completely drain the plant (or plant component) and let it cool down until the temperature is below the media vaporization temperature and cannot cause scalding.
11. Correctly decontaminate, rinse and ventilate the plant or plant component.
12. Lay piping so that the product is protected against transverse and bending forces, and also from vibrations and tension.
13. Only install the product between matching aligned pipes (see chapters below).
14. Please note the flow direction (see chapter "Flow direction").
15. Please note the installation position (see chapter "Installation position").

9.2 Installation with inserts for solvent cementing**NOTICE****Solvent cement**

- ▶ The solvent cement is not included in the scope of delivery.
- Only use suitable solvent cement!

1. Carry out preparations for installation (see chapter "Preparations for installation").

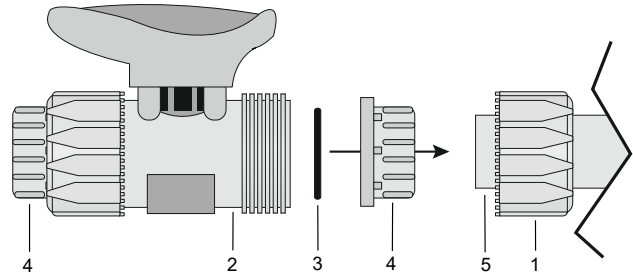

2. Unscrew the union nut **1** from the ball valve body **2**.
3. Reinsert the gasket **3** if necessary.

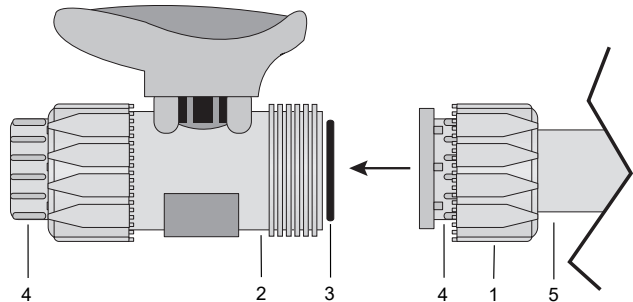

4. Push the union nut **1** over the piping **5**.
5. Prepare solvent cementing surfaces as specified by the solvent cement manufacturer.
6. Apply solvent cement on the inside of the insert **4** and on the outside of the piping **5** as specified by the solvent cement manufacturer.
7. Push the piping **5** into the insert **4**.
8. Screw the union nut **1** to the ball valve body **2** again.
9. Connect the other connections of the ball valve body **2** with the piping **5** in the same manner.

9.3 Installation with inserts for welding

1. Carry out preparations for installation (see chapter "Preparing for installation").
2. Adhere to good welding practices!

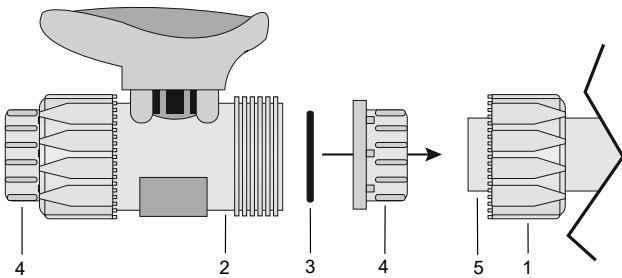

3. Unscrew the union nut **1** from the ball valve body **2**.
4. Reinsert the gasket **3** if necessary.

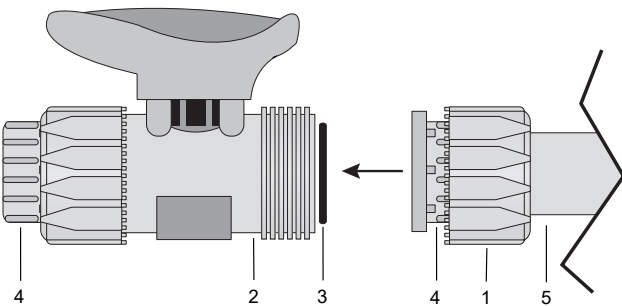

5. Push the union nut **1** over the piping **5**.
6. Push the piping **5** into the insert **4**.
7. Weld the piping **5** to the insert **4** with a suitable welding method and appropriate welding parameters and allow to cool down.
8. Screw the union nut **1** to the ball valve body **2** again.
9. Connect the other connections of the ball valve body **2** with the piping **5** in the same manner.

9.4 Installation with screw-type inserts

NOTICE

Thread sealant

- ▶ The thread sealant is not included in the scope of delivery.
- Only use appropriate thread sealant.

1. Keep thread sealant ready.
2. Carry out preparations for installation (see chapter "Preparing for installation").

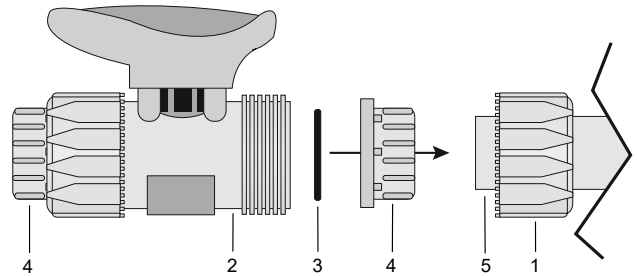

3. Unscrew the union nut **1** from the ball valve body **2**.
4. Reinsert the gasket **3** if necessary.

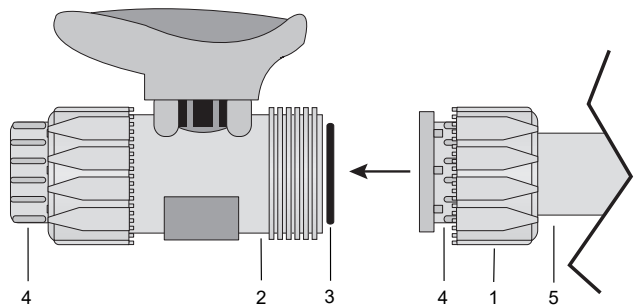

5. Push the union nut **1** over the piping **5**.
6. Apply thread sealant on connection thread.
7. Screw the insert **4** into the piping **5**.
8. Screw the union nut **1** to the ball valve body **2** again.
9. Connect the other connections of the ball valve body **2** with the piping **5** in the same manner.

9.5 Installation with flanged connection

NOTICE

Sealing material

- ▶ The sealing material is not included in the scope of delivery.
- Only use appropriate sealing material.

NOTICE

Connector elements

- ▶ The connector elements are not included in the scope of delivery.
- Only use connector elements made of approved materials.
- Observe permissible tightening torque of the bolts.

1. Keep sealing material ready.
2. Carry out preparations for installation (see chapter "Preparing for installation").
3. Ensure clean, undamaged sealing surfaces on the connection flanges.
4. Align flanges carefully before installing them.
5. Clamp the product centrally between the piping with flanges.
6. Centre the gaskets.
7. Connect the valve flange and the piping flange using appropriate sealing materials and matching bolting.
8. Use all flange holes.
9. Tighten the bolts diagonally.

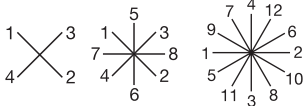

10. Re-attach or reactivate all safety and protective devices.

10 Electrical connection of electrical position indicators (optional accessories)

10.1 Connection diagrams

Microswitch EP1

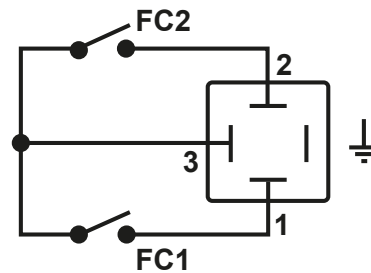
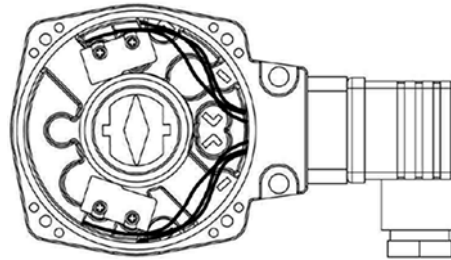

- 1 = Signal 1 - OPEN
- 2 = Signal 2 - CLOSED
- 3 = Common GND
- FC1 = Microswitch 1
- FC2 = Microswitch 2

Proximity switch EP2 PNP/NPN, 2-wire

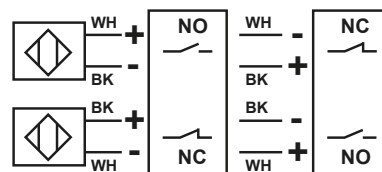
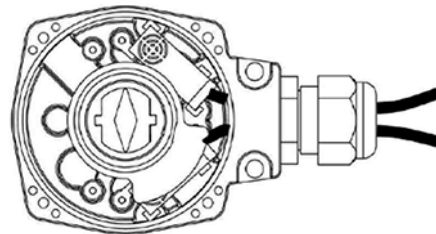

- NO = Normally open
- NC = Normally closed
- WH = white
- BK = black

Proximity switch EP3, Namur

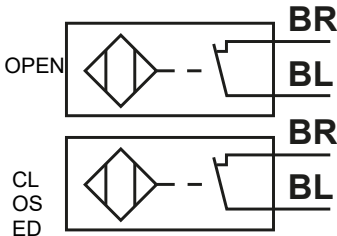
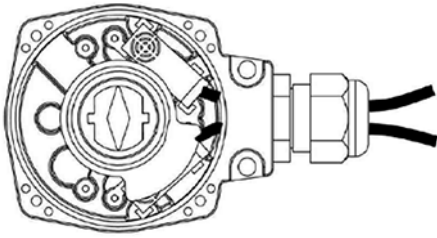

BL = blue
BR = brown

11 Commissioning

1. Check the tightness and the function of the product (close and reopen the product). Due to the setting behavior of elastomers, the bolts may need to be retightened following the installation and commissioning of the valve.
2. Flush the piping system of new plant and following repair work (the product must be fully open).
 - ⇒ Harmful foreign matter has been removed.
 - ⇒ The product is ready for use.
3. Commission the product.

12 Operation

12.1 Handle

NOTICE

► The opening of the ball valves with a handle is variable but cannot be engaged and locked.

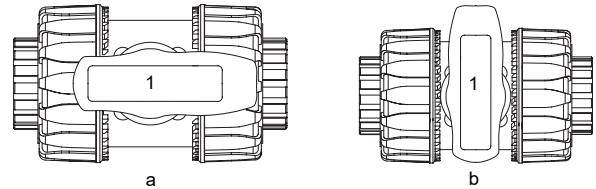

Fig. 1: Handle operation (DN 10 - 50)

Item	Name
1	Handle
a	Ball valve open
b	Ball valve closed

1. Move the handle 1 to the desired position.

NOTICE

- **Fully open ball valve:**
- Handle 1 is in piping direction.
- **Fully closed ball valve:**
- Handle 1 is across the piping.

Securing the handle (optional):



2. Remove the handle 1 from the ball valve.
3. Fit the locking device 2 of the handle.
4. Mount the handle 1 to the ball valve again.
5. Optional: Fit a padlock.

12.2 Hand lever

NOTICE

- ▶ The hand lever can be locked in 12 positions.

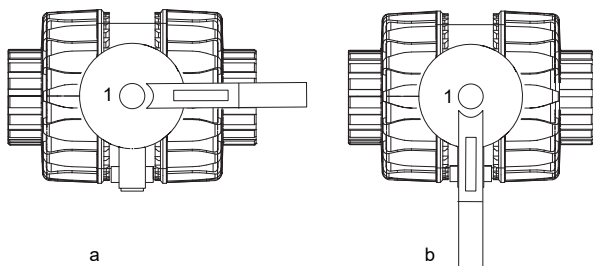

Fig. 2: Hand lever operation (DN 65 - 100)

Item	Name
1	Hand lever
a	Ball valve open
b	Ball valve closed

1. Move the hand lever 1 to the desired position.

NOTICE

- ▶ **Fully open ball valve:**
- ▶ Hand lever 1 is in piping direction.
- ▶ **Fully closed ball valve:**
- ▶ Hand lever 1 is across the piping.

Securing the hand lever:

2. Open the cover of the hand lever 1 (for DN 80 - 100).
3. Move the red lever to the "LOCK" position.

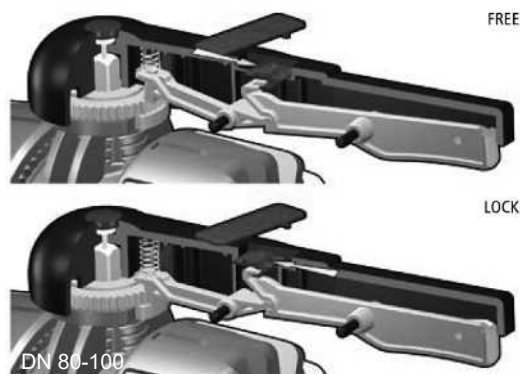

4. Optional: Fit a padlock.

12.3 Threaded connection locking devices

2/2-way ball valve DN 10–50

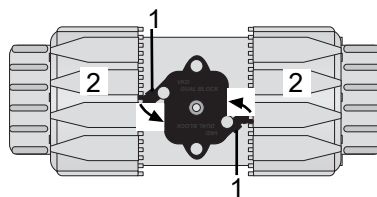

1. Press the latches 1 together and hold in position.

⇒ The teeth of the threaded connection locking device are retracted.

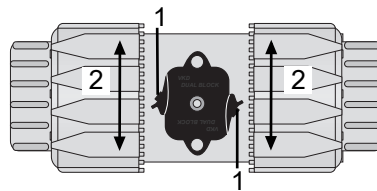

2. Turn the union nuts 2 to the desired position.

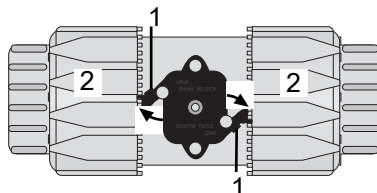

3. Release the latches 1 of the threaded connection locking device.

⇒ The teeth of the threaded connection locking device engage with the teeth of the union nuts 2 and fix them in place.

2/2-way ball valve DN 65–100

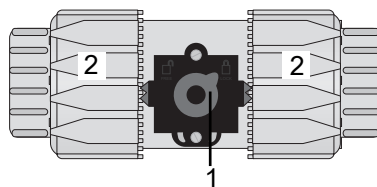

4. Turn the red blocking knob anticlockwise to the **FREE** position.

⇒ The teeth of the threaded connection locking device are retracted.

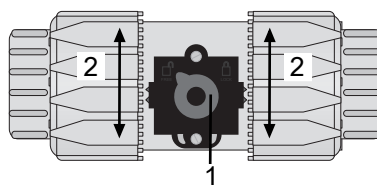

5. Turn the union nuts 2 to the desired position.

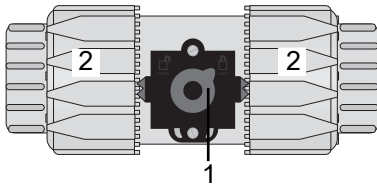

6. Turn the red blocking knob clockwise to the **LOCK** position.
- ⇒ The teeth of the threaded connection locking device engage with the teeth of the union nuts **2** and fix them in place.

3/2-way ball valve

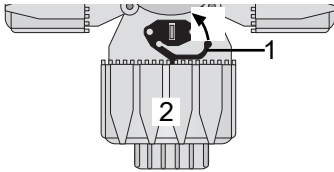

7. Press the latch **1** together and hold in position.
- ⇒ The tooth of the threaded connection locking device is retracted.

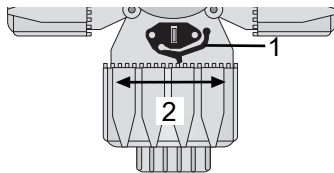

8. Turn the union nut **2** to the desired position.

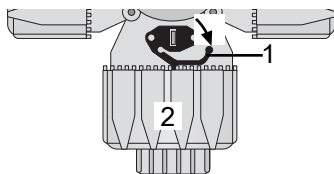

9. Release the latch **1** of the threaded connection locking device.
- ⇒ The tooth of the threaded connection locking device engages with the teeth of the union nut **2** and fixes it in place.

13 Troubleshooting

Error	Possible cause	Troubleshooting
The product does not open or does not open fully	Foreign matter in the product	Remove and clean the product
The product does not close or does not close fully	Foreign matter in the product	Remove and clean the product
Joint between ball valve body and piping is leaking	Ball valve body installed incorrectly in piping	Check installation of ball valve body in piping
	Flange bolting loose/thread leaking	Retighten flange bolting / reseal threads
	Sealing material faulty	Replace sealing material
Ball valve body leaking	Ball valve body faulty	Check ball valve body for potential damage and replace if necessary
No flow	Ball incorrectly adjusted	Turn ball to the correct position

14 Inspection and maintenance

The operator must carry out regular visual examination of the GEMÜ products dependent on the operating conditions and the potential danger in order to prevent leakage and damage.

The product also must be disassembled and checked for wear in the corresponding intervals.

1. Have servicing and maintenance work performed by trained personnel.
2. Wear appropriate protective gear as specified in plant operator's guidelines.
3. Shut off plant or plant component.
4. Secure the plant or plant component against recommissioning.
5. Depressurize the plant or plant component.
6. Actuate GEMÜ products which are always in the same position four times a year.

NOTICE

Exceptional maintenance work!

- ▶ Damage to the GEMÜ product
- Any maintenance work and repairs not described in these operating instructions must not be performed without consulting the manufacturer first.

⚠ CAUTION

Use of incorrect spare parts!

- ▶ Damage to the GEMÜ product
- ▶ Manufacturer liability and guarantee will be void
- Use only genuine parts from GEMÜ.

⚠ CAUTION



Hot plant components!

- ▶ Risk of burns
- Only work on plant that has cooled down.

⚠ WARNING

The equipment is subject to pressure!

- ▶ Risk of severe injury or death
- Depressurize the plant.
- Completely drain the plant.

14.1 Spare parts

2/2-way ball valve DN 10 - 50

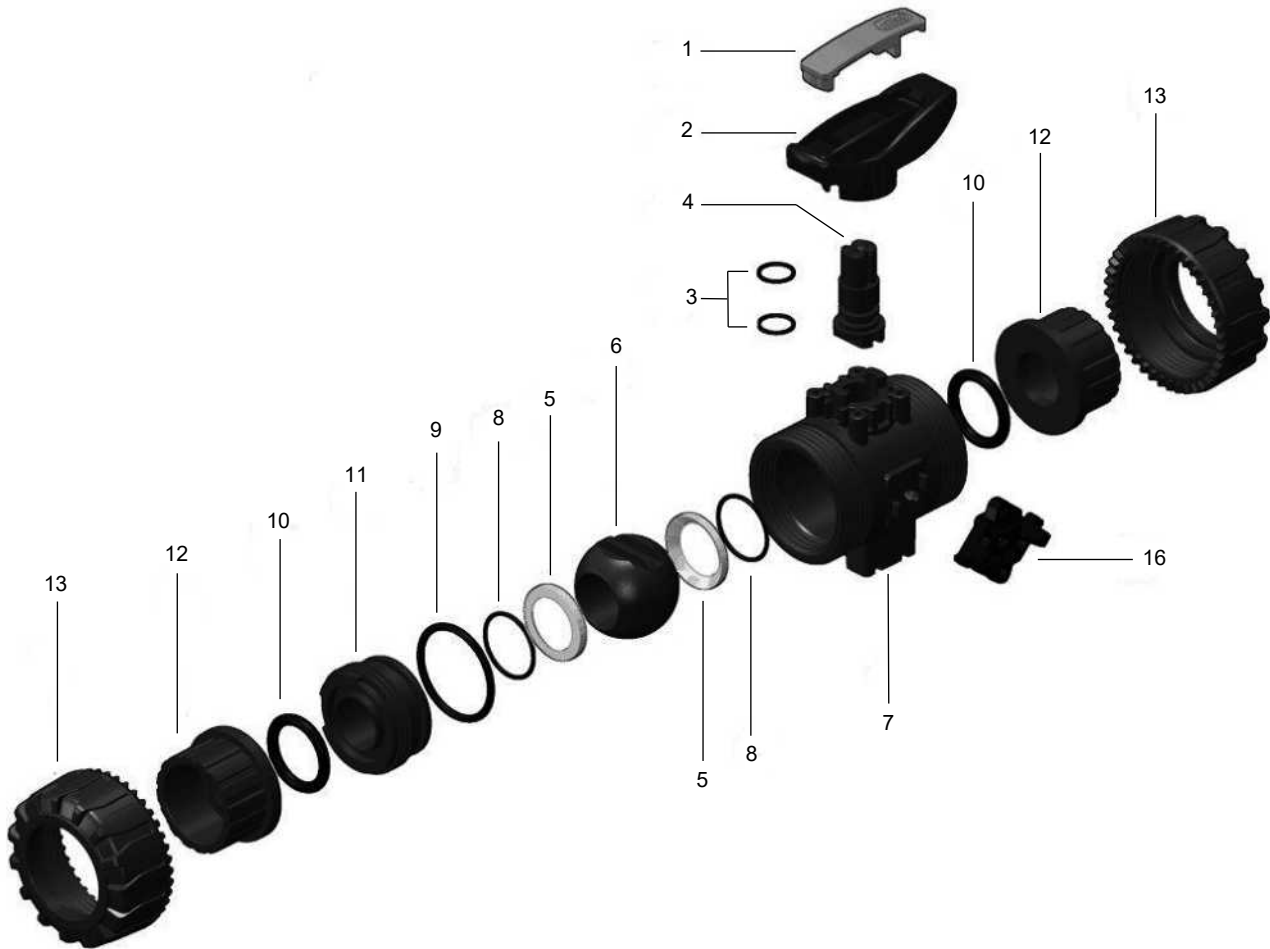

Item	Name	Design	Order description
3	Seal kit	DNXX, FPM DNXX, EPDM	717 XXSDS D4 717 XXSDS D14
5			
8			
9			
10			
4	Spindle	DNXX	717 XXPSP M
6	Ball, T-port	DNXX	717 XXPKUMT
	Ball, L-port	DNXX	717 XXPKUML
12	Insert	DNXX	717 XXPEL
13	Union nut	DNXX	717 XXPUM

XX - corresponds to nominal sizes DN 10 – 50.

2/2-way ball valve DN 65 - 100

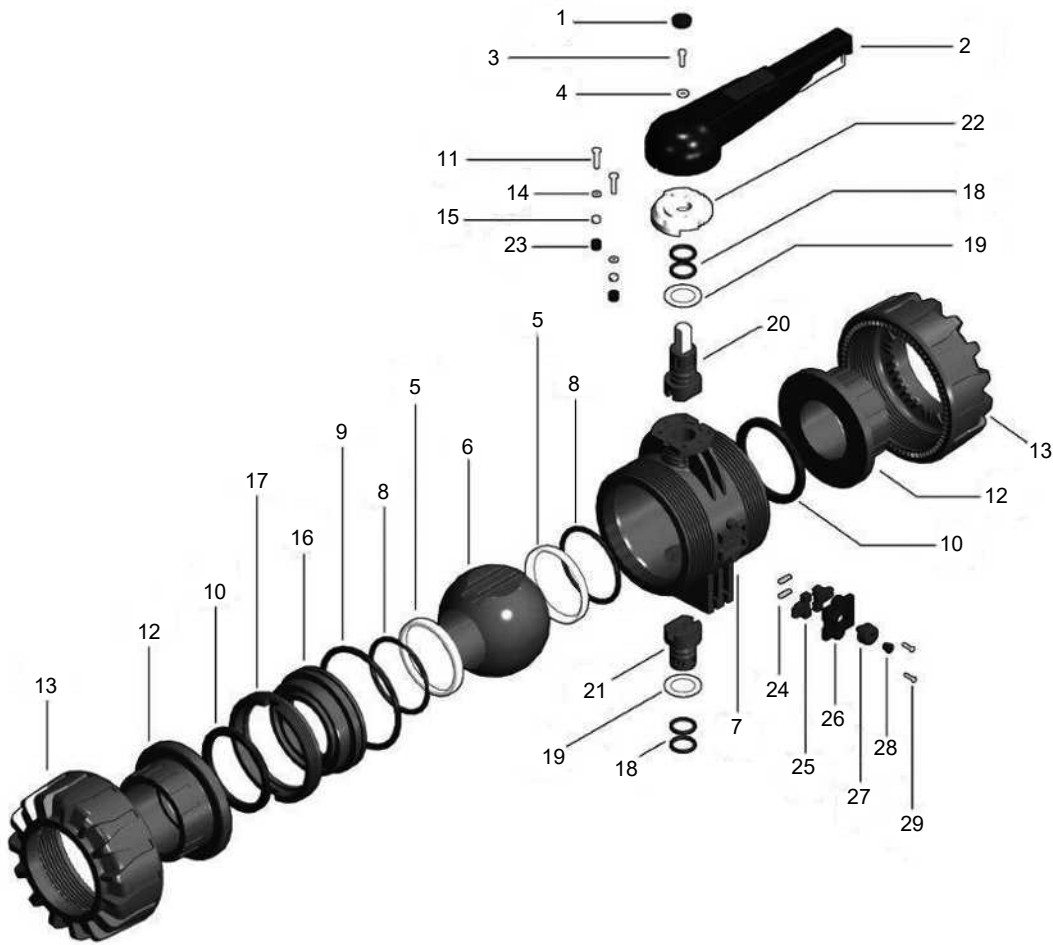

Item	Name	Design	Order description
3	Seal kit	DNXX, FPM	717 XXSDS D4
5		DNXX, EPDM	717 XXSDS D14
8			
9			
10			
4	Spindle	DNXX	717 XXPSP M
6	Ball, T-port	DNXX	717 XXPKUMT
	Ball, L-port	DNXX	717 XXPKUML
12	Insert	DNXX	717 XXPEL
13	Union nut	DNXX	717 XXPUM

XX - corresponds to nominal sizes DN 65 – 100.

3/2-way ball valve DN 10 - 50

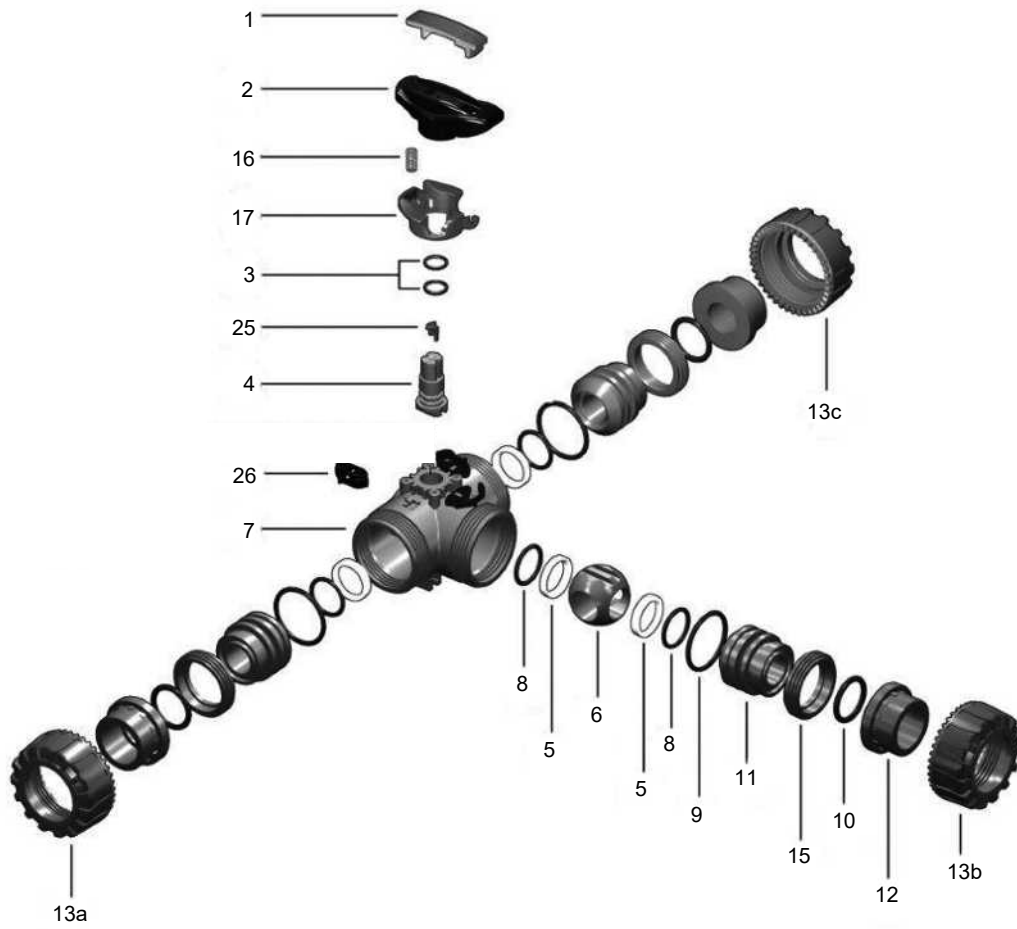

Item	Name	Design	Order description
3	Seal kit	DNXX, FPM	717 XXSDS M4
5		DNXX, EPDM	717 XXSDS M14
8			
9			
10			
4	Spindle	DNXX	717 XXPSP M
6	Ball, T-port	DNXX	717 XXPKUMT
	Ball, L-port	DNXX	717 XXPKUML
12	Insert	DNXX	717 XXPEL
13	Union nut	DNXX	717 XXPUM

XX - corresponds to nominal sizes DN 10 – 50.

14.2 Replacement of spare parts

NOTICE

- ▶ For an overview of spare parts see chapter "Spare parts".

14.2.1 Disassembly of 2/2-way ball valve DN 10-50

1. Depressurize the plant or plant component.
2. Release the threaded connection locking device (see chapter "Threaded connection locking devices").

NOTICE

- ▶ The threaded connection locking device can also be pulled off from the ball valve body when assembling or disassembling the ball valve.

3. Unscrew the union nuts **13** from the ball valve body **7**.
4. Remove the insert **12**.
5. Remove the gasket **10**.
6. Remove the ball valve from the piping.
7. Hold the ball valve vertically and open by 45°.
- ⇒ The remaining residual liquid runs out.
8. Move the ball valve to the CLOSED position.
9. Using the key insert **1** for the handle **2**, turn out the seal carrier **11**.
10. Remove the handle **2**.
11. Remove O-ring **9**, O-ring **8** and gasket **5**.
12. Carefully press out the ball **6** (taking care not to scratch the ball).
13. Press the spindle(s) **4** (**21**) into the ball valve body and remove.
14. Refit all parts in the reverse order.

14.2.2 Disassembly of 2/2-way ball valve DN 65-100

1. Depressurize the plant or plant component.
2. Release the threaded connection locking device (see chapter "Threaded connection locking devices").

NOTICE

- ▶ The threaded connection locking device can also be pulled off from the ball valve body when assembling or disassembling the ball valve.

3. Unscrew the union nuts **13** from the ball valve body **7**.
4. Remove the insert **12**.
5. Remove the gasket **10**.
6. Remove the ball valve from the piping.
7. Move the ball valve to the open position.
8. Remove the hand lever protection cap **1**.
9. Release the hand lever screw **3** and washer **4** and remove them.
10. Remove the hand lever.
11. Undo and remove the screws.
12. Remove the ratchet plate.
13. Using the key insert for the hand lever, turn out the threaded ring **17** and the seal carrier **16**.
14. Remove O-ring **9**, O-ring **8** and gasket **5**.
15. Carefully press out the ball **6** (taking care not to scratch the ball).
16. Press the upper spindle **20** and lower spindle **21** into the ball valve body and remove.
17. Refit all parts in the reverse order.

14.2.3 Disassembly of 3/2-way ball valve DN 10-50

1. Depressurize the plant or plant component.
2. Release the threaded connection locking device (see chapter "Threaded connection locking devices").

NOTICE

- ▶ The threaded connection locking device can also be pulled off from the ball valve body when assembling or disassembling the ball valve.

3. Unscrew the union nuts **13** from the ball valve body **7**.
 4. Remove the insert **12**.
 5. Remove the gasket **10**.
 6. Remove the ball valve from the piping.
 7. Hold the ball valve vertically and open by 45°.
- ⇒ The remaining residual liquid runs out.
8. Move the ball valve to the CLOSED position.
 9. Using the key insert **1** for the handle **2**, turn out the seal carrier **11**.
 10. Remove the handle **2**.
 11. Remove O-ring **9**, O-ring **8** and gasket **5**.
 12. Carefully press out the ball **6** (taking care not to scratch the ball).
 13. Press the spindle(s) **4** (21) into the ball valve body and remove.
 14. Refit all parts in the reverse order.

14.3 Cleaning the product

⚠ CAUTION

Cleaning agent

- ▶ Damage to the GEMÜ product.
- The plant operator is responsible for selecting the cleaning material and performing the procedure.

- Clean the product with a damp cloth.
- Do **not** clean the product with a high pressure cleaning device.

15 Removal from piping

1. Remove the clamp or screw connections in reverse order to installation.
2. Remove welded or solvent cemented connections using a suitable cutting tool.
3. Observe the safety information and accident prevention regulations.

16 Returns

Legal regulations for the protection of the environment and personnel require that the completed and signed return delivery note is included with the dispatch documents. Returned goods can be processed only when this note is completed. If no return delivery note is included with the product, GEMÜ cannot process credits or repair work but will dispose of the goods at the operator's expense.

1. Clean the product.
2. Request a return delivery note from GEMÜ.
3. Complete the return delivery note.
4. Send the product with a completed return delivery note to GEMÜ.

17 EU Declaration of conformity 2-way ball valve



DICHIARAZIONE / DECLARATION

FIP dichiara che l'attrezzatura a pressione / *FIP declares that the pressure equipment:*

TIPO VALVOLA / *VALVE TYPE:* sfera, membrana, farfalla, non-ritorno / *ball, diaphragm, butterfly, check*
MODELLO / *MODEL:* VKD / VXE / VEE / TKD / VKR / VM / MK / DK / DM / FK / FE / VR / SXE / SSE / VA
/ VZ / SR / VV / RV

GAMMA DN / *DN RANGE:* 32 ÷ 100

MATERIALE / *MATERIAL:* PVC-U, PVC-C, PPH, PVDF

secondo la Procedura di Valutazione della Conformità
according to the Assessment of Conformity Procedure:
Modulo / *Module* A2

sorvegliato dall'Organismo Notificato / *inspected by the Notified Body:*
PASCAL (n° 1115)
Via Scarsellini, 13
I-20161 (MI)
ITALY

in accordo alla norma / *according to the standard:*
EN ISO 16135, EN ISO 16136, EN ISO 16137, EN ISO 16138 e / *and* ISO 9393

è conforme ai requisiti della Direttiva 2014/68/EU per le Attrezzature a Pressione.
is in conformity with the requirements of the Pressure Equipment Directive 2014/68/EU.

Per quanto concerne la valvole con DN < 32 mm, sono conformi alla direttiva PED 2014/68/EU Art.4
Par.3, esse non possono essere marcate CE, ma sono progettate e collaudate secondo la stessa
procedura delle dimensioni maggiori quindi in accordo a / *For what concern the valve sizes lower than*
DN 32 mm, they meet the PED 2014/68/EU Art.4 Par.3, so they can't be CE marked but, they are
designed and tested in the same way of bigger so, they completely fulfil the criteria of

EN ISO 16135, EN ISO 16136, EN ISO 16137, EN ISO 16138 e / *and* ISO 9393

In fede / *Faithfully*

Casella, 8/7/2016

Ing. Oleg Clericuzio
QUALITY ASSURANCE MANAGER

The underlined type (VKD) corresponds
to GEMÜ 717 (2-way ball valve)

FIP - Formatura Iniezione Polimeri S.p.A.
Società Unipersonale - Soggetta a direzione e
coordinamento da parte di Aliaxis Holding Italia S.p.A.
Loc. Pian di Parata - 16015 Casella - Genova - Italia
Tel +39 (010) 96211 - Fax +39 (010) 9621209

www.fipnet.it

C.F. - P.IVA - Iscrizione al Registro delle Imprese
di Genova Nr.: 00276860103
REA C.C.I.A.A. Genova Nr.: 196879
Capitale Sociale: €6.200.000

Dati bancari
IBAN: IT 53L 01 005 01400
00000024674
Swift/BIC: BNLIITRRGEX
Banca Nazionale del Lavoro

18 EU Declaration of conformity 3-way ball valve**DICHIARAZIONE / DECLARATION**

FIP dichiara che l'attrezzatura a pressione / *FIP declares that the pressure equipment:*

TIPO VALVOLA / *VALVE TYPE:* sfera, membrana, farfalla, non-ritorno / *ball, diaphragm, butterfly, check*
 MODELLO / *MODEL:* VKD / VXE / VEE / TKD / VKR / VM / MK / DK / DM / FK / FE / VR / SXE / SSE / VA
 / VZ / SR / VV / RV

GAMMA DN / *DN RANGE:* 32 ÷ 100

MATERIALE / *MATERIAL:* PVC-U, PVC-C, PPH, PVDF

secondo la Procedura di Valutazione della Conformità
according to the Assessment of Conformity Procedure:
 Modulo / *Module A2*

sorvegliato dall'Organismo Notificato / *inspected by the Notified Body:*

PASCAL (n° 1115)

Via Scarsellini, 13

I-20161 (MI)

ITALY

in accordo alla norma / *according to the standard:*

EN ISO 16135, EN ISO 16136, EN ISO 16137, EN ISO 16138 e / *and ISO 9393*

è conforme ai requisiti della Direttiva 2014/68/EU per le Attrezzature a Pressione.
is in conformity with the requirements of the Pressure Equipment Directive 2014/68/EU.

Per quanto concerne la valvole con DN < 32 mm, sono conformi alla direttiva PED 2014/68/EU Art.4
 Par.3, esse non possono essere marcate CE, ma sono progettate e collaudate secondo la stessa
 procedura delle dimensioni maggiori quindi in accordo a / *For what concern the valve sizes lower than*
DN 32 mm, they meet the PED 2014/68/EU Art.4 Par.3, so they can't be CE marked but, they are
designed and tested in the same way of bigger so, they completely fulfil the criteria of

EN ISO 16135, EN ISO 16136, EN ISO 16137, EN ISO 16138 e / *and ISO 9393*

In fede / *Faithfully*

Casella, 8/7/2016

Ing. Oleg Clericuzio
 QUALITY ASSURANCE MANAGER

The underlined type (TKD) corresponds
 to GEMÜ 717 (3-way ball valve)

FIP - Formatura Iniezione Polimeri S.p.A.
 Società Unipersonale - Soggetta a direzione e
 coordinamento da parte di Aliaxis Holding Italia S.p.A.
 Loc. Pian di Parata - 16015 Casella - Genova - Italia
 Tel +39 (010) 96211 - Fax +39 (010) 9621209

www.fipnet.it

C.F. - P.IVA - Iscrizione al Registro delle Imprese
 di Genova Nr.: 00276860103
 REA C.C.I.A.A. Genova Nr.: 196879
 Capitale Sociale: €6.200.000

Dati bancari
 IBAN: IT 53L 01 005 01400
 00000024674
 Swift/BIC: BNLITRRGEX
 Banca Nazionale del Lavoro



GEMÜ Gebr. Müller Apparatebau GmbH & Co. KG
Fritz-Müller-Straße 6-8, 74653 Ingelfingen-Criesbach, Germany
Phone +49 (0) 7940 1230 · info@gemue.de
www.gemu-group.com

Subject to alteration

07.2023 | 88593388