

GEMÜ 8500

Electrically operated pilot solenoid valve

EN **Operating instructions**



further information
webcode: GW-8500



All rights including copyrights or industrial property rights are expressly reserved.

Keep the document for future reference.

© GEMÜ Gebr. Müller Apparatebau GmbH & Co. KG
24.10.2023

Contents

1 General information	4	20 Declaration of conformity in accordance with	
1.1 Information	4	2014/35/EU (Low Voltage Directive) and 2014/30/	
1.2 Symbols used	4	EU (EMC Directive)	24
1.3 Definition of terms	4		
1.4 Warning notes	4		
2 Safety information	5		
3 Product description	5		
3.1 Construction	5		
3.2 Description	5		
3.3 Function	5		
4 Correct use	6		
5 Order data	7		
5.1 Order codes	7		
5.1.13 Additional function	7		
5.2 Order example	7		
6 Technical data	8		
6.1 Medium	8		
6.2 Temperature	8		
6.3 Pressure	8		
6.5 Mechanical data	8		
6.6 Electrical data	8		
7 Dimensions	9		
7.1 Thread	9		
7.2 NAMUR version	9		
7.3 NAMUR flex plate	10		
7.4 Mounting plate for air connectors 3/8" and 1/2"	10		
7.5 Interlinking system	11		
7.5.1 Individual parts	11		
7.5.2 Mounted versions	12		
7.6 Solenoid	13		
8 Manufacturer's information	14		
8.1 Delivery	14		
8.2 Transport	14		
8.3 Storage	14		
8.4 Scope of delivery	14		
9 Assembly	14		
10 Pneumatic connection	15		
10.1 Circuit diagram	15		
11 Electrical connection	16		
11.1 Manual override	17		
12 Interlinking system	18		
12.1 3/2-way design	18		
12.2 5/2-way design	18		
13 Commissioning	19		
14 Fault clearance	20		
15 Inspection and maintenance	21		
15.1 Solenoid coil replacement	21		
16 Disassembly	21		
17 Disposal	21		
18 Returns	22		
19 Declaration of conformity according to 2014/68/ EU (Pressure Equipment Directive)	23		

1 General information

1.1 Information

- The descriptions and instructions apply to the standard versions. For special versions not described in this document the basic information contained herein applies in combination with any additional special documentation.
- Correct installation, operation, maintenance and repair work ensure faultless operation of the product.
- Should there be any doubts or misunderstandings, the German version is the authoritative document.
- Contact us at the address on the last page for staff training information.

1.2 Symbols used

The following symbols are used in this document:

Symbol	Meaning
●	Tasks to be performed
▶	Response(s) to tasks
-	Lists

1.3 Definition of terms

Working medium

The medium that flows through the GEMÜ product.

1.4 Warning notes

Wherever possible, warning notes are organised according to the following scheme:

SIGNAL WORD	
Possible symbol for the specific danger	Type and source of the danger <ul style="list-style-type: none"> ▶ Possible consequences of non-observance. ● Measures for avoiding danger.

Warning notes are always marked with a signal word and sometimes also with a symbol for the specific danger.

The following signal words and danger levels are used:



⚠ DANGER	
	Imminent danger! <ul style="list-style-type: none"> ▶ Non-observance can cause death or severe injury.

⚠ WARNING	
	Potentially dangerous situation! <ul style="list-style-type: none"> ▶ Non-observance can cause death or severe injury.

⚠ CAUTION	
	Potentially dangerous situation! <ul style="list-style-type: none"> ▶ Non-observance can cause moderate to light injury.

NOTICE	
	Potentially dangerous situation! <ul style="list-style-type: none"> ▶ Non-observance can cause damage to property.

The following symbols for the specific dangers can be used within a warning note:

Symbol	Meaning
	Danger – high voltage
	Danger - hot surfaces

2 Safety information

The safety information in this document refers only to an individual product. Potentially dangerous conditions can arise in combination with other plant components, which need to be considered on the basis of a risk analysis. The operator is responsible for the production of the risk analysis and for compliance with the resulting precautionary measures and regional safety regulations.

The document contains fundamental safety information that must be observed during commissioning, operation and maintenance. Non-compliance with these instructions may cause:

- Personal hazard due to electrical, mechanical and chemical effects.
- Hazard to nearby equipment.
- Failure of important functions.
- Hazard to the environment due to the leakage of dangerous substances.

The safety information does not take into account:

- Unexpected incidents and events, which may occur during installation, operation and maintenance.
- Local safety regulations which must be adhered to by the operator and by any additional installation personnel.

Prior to commissioning:

1. Transport and store the product correctly.
2. Do not paint the bolts and plastic parts of the product.
3. Carry out installation and commissioning using trained personnel.
4. Provide adequate training for installation and operating personnel.
5. Ensure that the contents of the document have been fully understood by the responsible personnel.
6. Define the areas of responsibility.
7. Observe the safety data sheets.
8. Observe the safety regulations for the media used.

During operation:

9. Keep this document available at the place of use.
10. Observe the safety information.
11. Operate the product in accordance with this document.
12. Operate the product in accordance with the specifications.
13. Maintain the product correctly.
14. Do not carry out any maintenance work and repairs not described in this document without consulting the manufacturer first.

In cases of uncertainty:

15. Consult the nearest GEMÜ sales office.

3 Product description

3.1 Construction

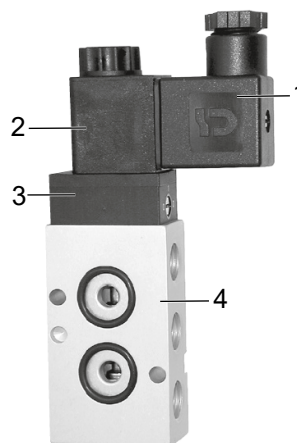

Item	Name	Materials
1	Plug	PA
2	Coil housing	PA
3	Pilot head	PA
4	Valve body	(AlCuMgSn)
	Seal materials	



3.2 Description

The GEMÜ 8500 servo assisted 3/2 or 5/2-way pilot solenoid valve is indirectly controlled. The body is made of aluminium. The plastic encapsulated coil is detachable. The piston valve has a soft elastomer seal.

3.3 Function

The GEMÜ 8500 pilot solenoid valve is designed to activate double or single acting pneumatic cylinder actuators or membrane actuators or other pneumatically operated positioning elements.

4 Correct use

 DANGER	
	Danger of explosion! <ul style="list-style-type: none">▶ Risk of severe injury or death.● Use of the pilot solenoid valve in potentially explosive areas is not permissible.● Only use the product in potentially explosive zones confirmed in the declaration of conformity (ATEX).

 WARNING	
Improper use of the product! <ul style="list-style-type: none">▶ Risk of severe injury or death▶ Manufacturer liability and guarantee will be void.● Only use the product in accordance with the operating conditions specified in the contract documentation and in this document.	

1. Use the product in accordance with the technical data.
2. Protect the product from direct weathering.

5 Order data

The order data provide an overview of standard configurations.

Please check the availability before ordering. Other configurations available on request.

Order codes

1 Type	Code
Pilot valve	8500

2 Way version	Code
3/2-way	32
5/2-way	52

3 NAMUR	Code
Flex plate	F
NAMUR	N
Thread	

4 DN	Code
DN 7	7

5 Body configuration	Code
Multi-port design	M

6 Connection type	Code
G 1/4, threaded socket, DIN ISO 228	G2

7 Valve body material	Code
AA-2015, AlCuMgSn	14

8 Seal material	Code
NBR	2

9 Control function	Code
Combined spring return	1
Pneumatic spring (ATEX)	A

10 Voltage/Frequency	Code
12 V DC	B1
24 V DC	C1
24 V/50–60 Hz	C4
48 V DC	D1
110 V/50–60 Hz	E4
230 V/50–60 Hz	L4

11 Special version	Code
Without	
180° rotation	R

12 Special version	Code
Without	
UL approval	U
ATEX version	X

13 Additional function	Code
Without	
Distance plate G3/8",G1/2" included	Z

Order example

Ordering option	Code	Description
1 Type	8500	Pilot valve
2 Way version	32	3/2-way
3 NAMUR	N	NAMUR
4 DN	7	DN 7
5 Body configuration	M	Multi-port design
6 Connection type	G2	G 1/4, threaded socket, DIN ISO 228
7 Valve body material	14	AA-2015, AlCuMgSn
8 Seal material	2	NBR
9 Control function	1	Combined spring return
10 Voltage/Frequency	C1	24 V DC
11 Special version		Without
12 Special version		Without
13 Additional function		Without

6 Technical data

6.1 Medium

Working medium: Filtered, lubricated or unlubricated compressed air which has no negative impact on the physical and chemical properties of the valve body and seal material.
Air quality acc. to ISO 8573-1:2010:7-4-4 for particles, water and oil

6.2 Temperature

Media temperature: AC operation: -10 to 50 °C
DC operation: -10 to 60 °C

6.3 Pressure

Operating pressure: 2.5 – 10 bar

Flow rate: 1250 NI/min

6.4 Product compliance

Machinery Directive: 2006/42/EC

EMC Directive: 2014/30/EU

Explosion protection: Special version X order code

ATEX marking: Gas:  II 2G Ex mb IIC T4/T5 Gb
Dust:  II 2D Ex mb tb IIIC T95°C, T130°C Db

6.5 Mechanical data

Protection class: IP 65

Installation position: Optional

Weight: 3/2-way standard: 0.21 kg
5/2-way standard: 0.25 kg
3/2-way and 5/2-way: 0.26 kg
NAMUR:

6.6 Electrical data

Power consumption: AC operation: 5 VA
DC operation: 3 W

Switching times: 20 ms ± 4 ms

Permissible voltage tolerance: ±10 % to VDE 0580

Duty cycle: Continuous duty

Electrical connection type: Plug, design B
Optional: ATEX version with 3 m cable (H05V2V2-F 3G1, external Ø 7 mm)

Wiring note: Special wiring on request. When using electronic switches and additional wiring, carefully design out any potential residual currents upon installation.

7 Dimensions

7.1 Thread

3/2-way version

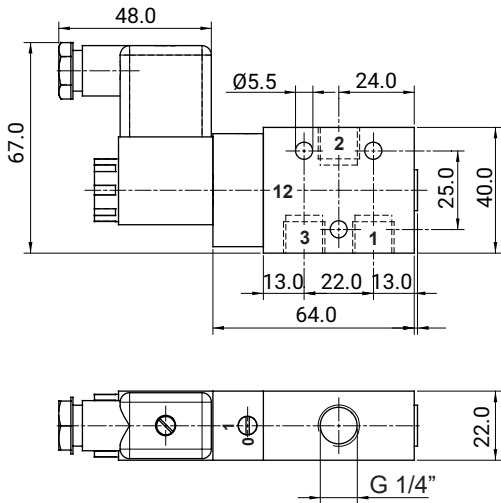

5/2-way version

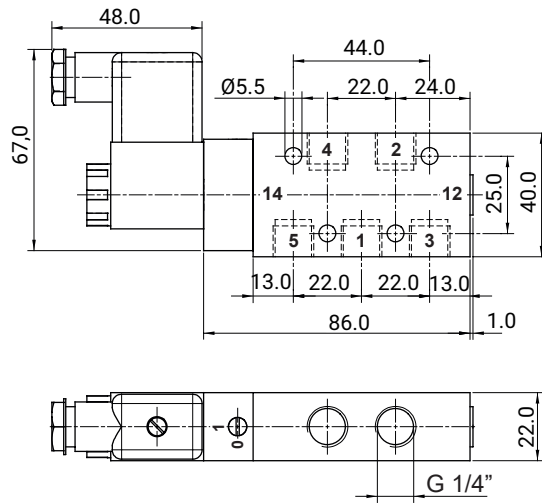

Dimensions in mm

7.2 NAMUR version

3/2-way version

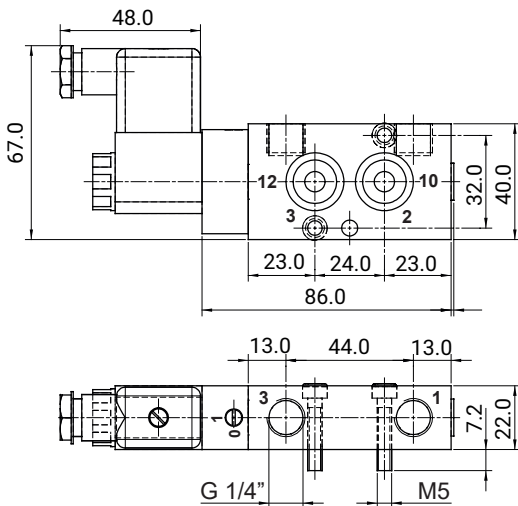

5/2-way version

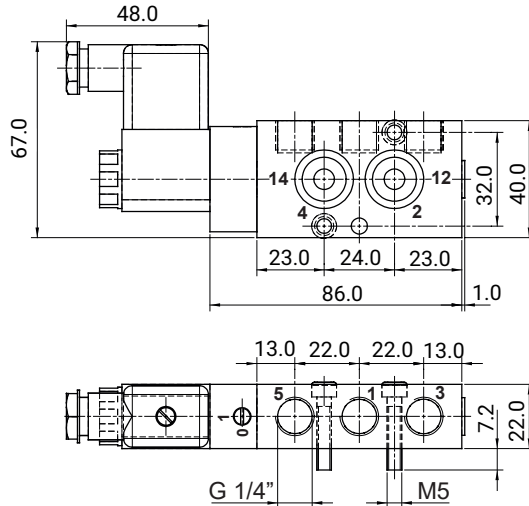

Dimensions in mm

7.3 NAMUR flex plate

For 5/2-way design (code 52), NAMUR standard 1/4"

By adding this flex plate, the valve becomes a 3/2-way NAMUR valve with spring chamber ventilation.

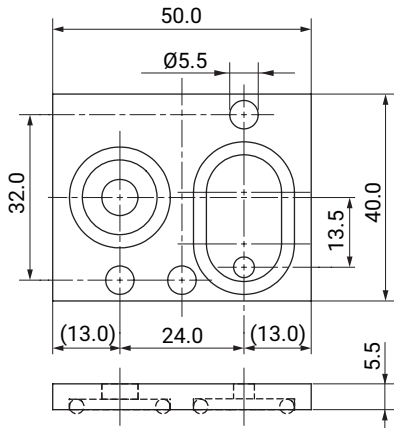

7.4 Mounting plate for air connectors 3/8" and 1/2"

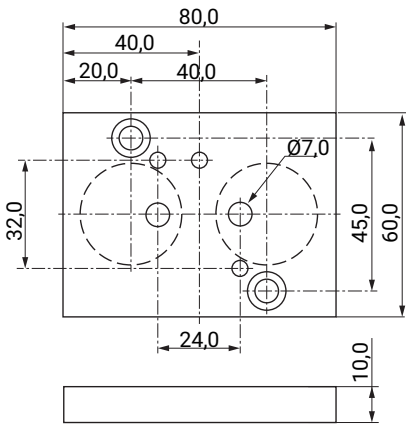

Pilot valve with mounting plate for air connectors 3/8" and 1/2"

The G1I2 set includes the 1/4" valve + the mounting plate ADPL G1/2 G1/4 10

Type	Designation	Item number
850032N 7M G214 21C1 Z	3/2 NAMUR pilot valve	88859708
850032N 7M G214 21L4 Z	3/2 NAMUR pilot valve	88859709
850052N 7M G214 21C1 Z	5/2 NAMUR pilot valve	88859710
850052N 7M G214 21L4 Z	5/2 NAMUR pilot valve	88859711

Mounting plate ADPL

Type	Designation	Item number
ADPL G1/2 G1/4 10	ZPN 6-10	88416005

7.5 Interlinking system

7.5.1 Individual parts

7.5.1.1 3/2-way design

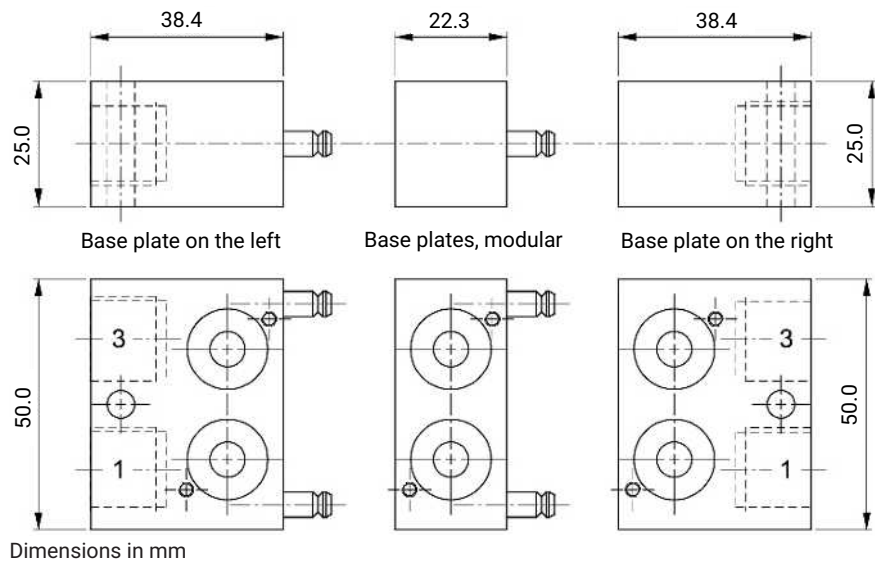

7.5.1.2 5/2-way design

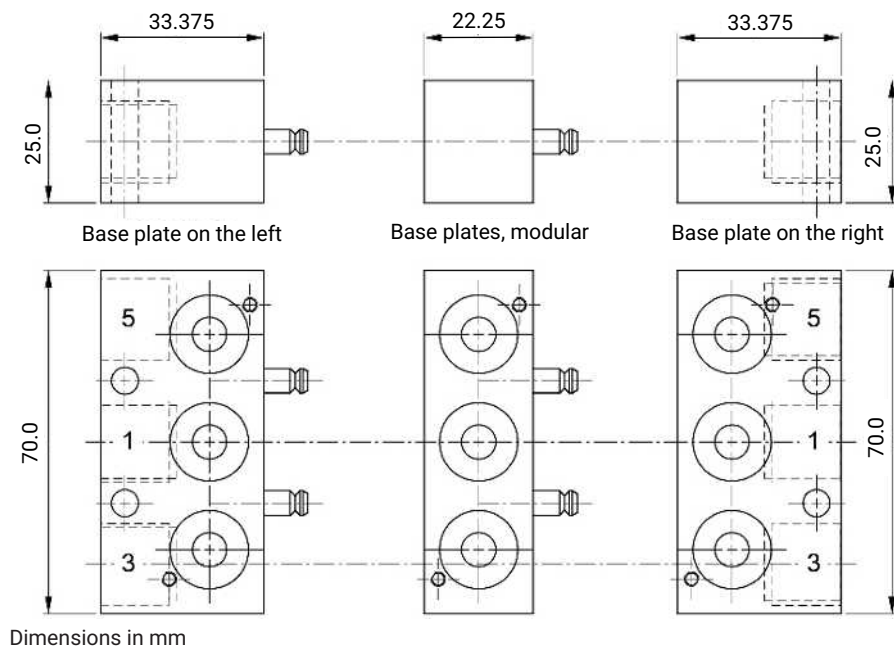

7.5.2 Mounted versions

7.5.2.1 3/2-way design

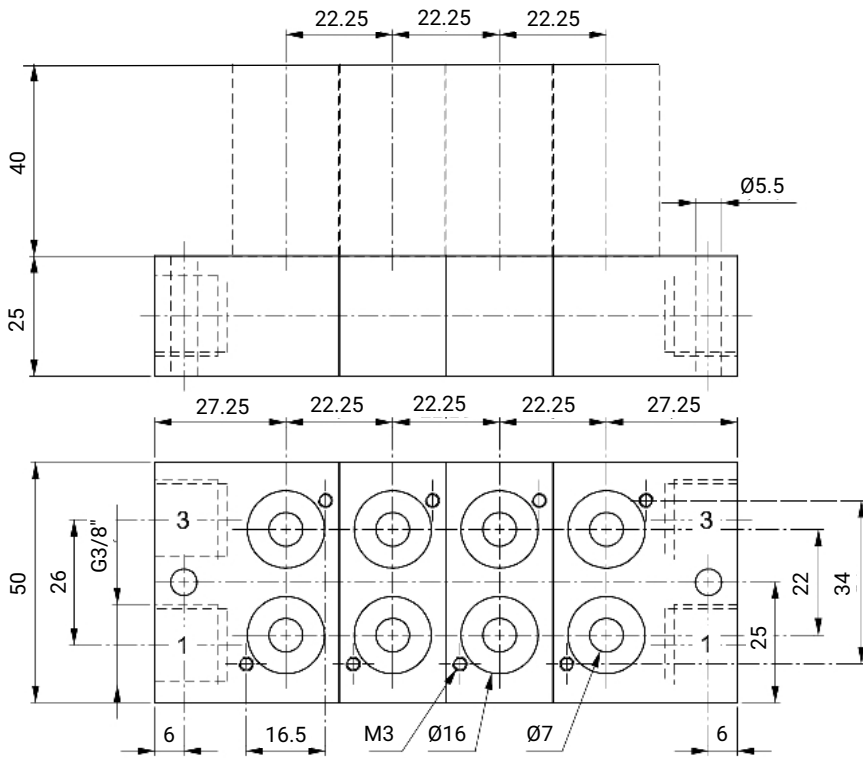

Dimensions in mm

7.5.2.2 5/2-way design

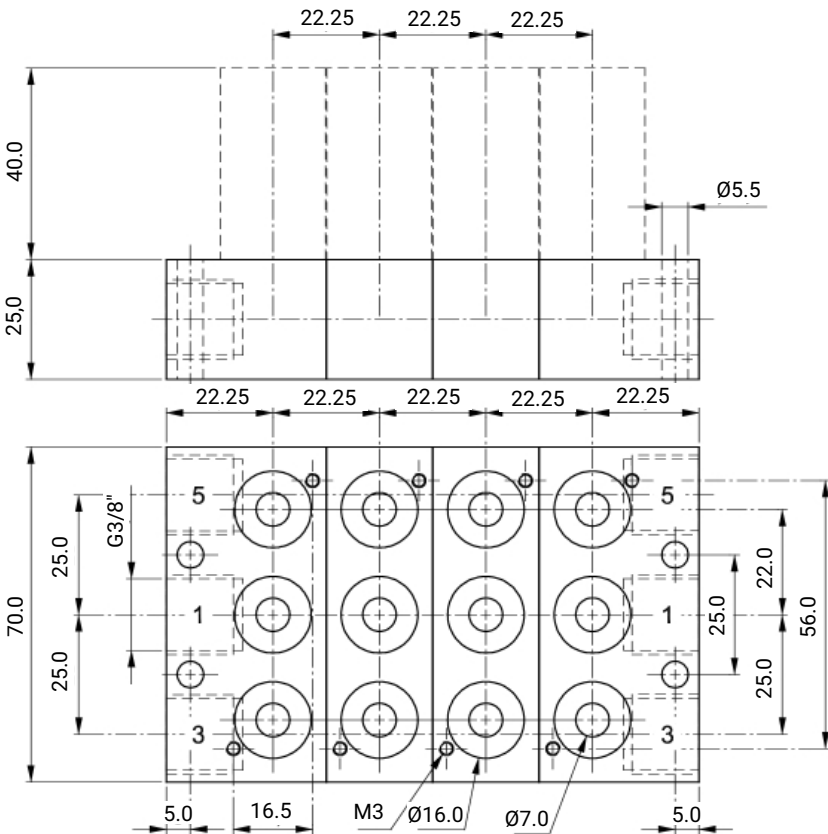

Dimensions in mm

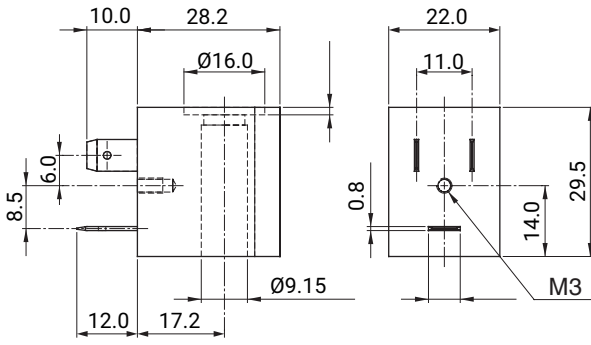
7.6 Solenoid

8 Manufacturer's information

8.1 Delivery

- Check that all parts are present and check for any damage immediately upon receipt.

The product's performance is tested at the factory. The scope of delivery is apparent from the dispatch documents and the design from the order number.

8.2 Transport

1. Only transport the product by suitable means. Do not drop. Handle carefully.
2. After the installation dispose of transport packaging material according to relevant local or national disposal regulations / environmental protection laws.

8.3 Storage

1. Store the product free from dust and moisture in its original packaging.
2. Avoid UV rays and direct sunlight.
3. Do not exceed the maximum storage temperature (see chapter "Technical data").
4. Do not store solvents, chemicals, acids, fuels or similar fluids in the same room as GEMÜ products and their spare parts.



8.4 Scope of delivery

The pilot solenoid valve is supplied as a separately packed component. The female threads are sealed with caps.

The following is included in the scope of delivery:

- Pilot solenoid valve with solenoid coil
- Plug
- Flex plate (only on NAMUR flex version (code F))

9 Assembly

 DANGER	
	<p>Risk of electric shock</p> <ul style="list-style-type: none"> ▶ There is a danger of injury or death (if operating voltage is higher than safe extra low voltage)! ● Before performing any work on the GEMÜ product, switch off power and protect circuit from being switched on again.

 CAUTION	
Functional impairment of the pilot solenoid valve by contaminated media!	
<ul style="list-style-type: none"> ▶ The pilot solenoid valve will cease to open or close if the control apertures are blocked or if the armature is blocked by dirt. ● The piping system should be cleaned prior to installation of the pilot solenoid valve. ● Fit a strainer with a mesh size of ≤ 0.25 mm in front of the valve inlet if the media are contaminated. ● Switch the pilot solenoid valve at least once a month. 	

 CAUTION	
Destruction of the pilot solenoid valve by freezable medium!	
<ul style="list-style-type: none"> ▶ The pilot solenoid valve is not frost-protected. ● Pilot solenoid valves using freezable media should only be operated above freezing point. 	

 CAUTION	
Danger from flow contrary to flow direction!	
<ul style="list-style-type: none"> ▶ Damage to the pilot solenoid valve. ● Only operate the pilot solenoid valve in flow direction. ● Take precautionary measures in case of expected reverse flow (e.g. check valve). 	

Prior to installation:

1. **Check the suitability of the pilot solenoid valve prior to the installation!**
See chapter "Technical data".
- Installation work must only be performed by trained personnel.
 - Use appropriate protective gear as specified in plant operator's guidelines.

Installation location:

NOTICE	
<ul style="list-style-type: none"> ▶ Battery mounting with central air supply possible. - Installation position: Optional. - Manual override and electrical plug must be accessible. 	

Installation:

2. Ensure the suitability of the valve for each respective use. The valve must be appropriate for the piping system operating conditions (medium, medium concentration, temperature and pressure) and the prevailing ambient conditions. Check the technical data of the valve and the materials.
3. Shut off plant or plant component.
4. Secure against recommissioning.
5. Depressurize the plant or plant component.
6. Completely drain the plant (or plant component) and let it cool down until the temperature is below the media vaporization temperature and cannot cause scalding.
7. If necessary, correctly decontaminate, rinse and ventilate the plant or plant component.
8. If necessary, fit a strainer in front of the valve inlet.
9. Carefully remove the caps from the female threads of the pilot solenoid valve.
10. Screw the pilot solenoid valve to the appropriate device with two screws.
11. Connect the control medium lines (see chapter "Pneumatic connection").
12. Connect the cable (see chapter "Electrical connection").

10 Pneumatic connection**NOTICE**

- ▶ Connect the control medium lines tension-free and without any bends or knots! Use appropriate connectors according to the application.

NOTICE

- ▶ The correct NAMUR plate must be fitted before connecting the control medium connectors (see chapter "NAMUR plate replacement").

Thread size of the control medium connectors:
G1/4

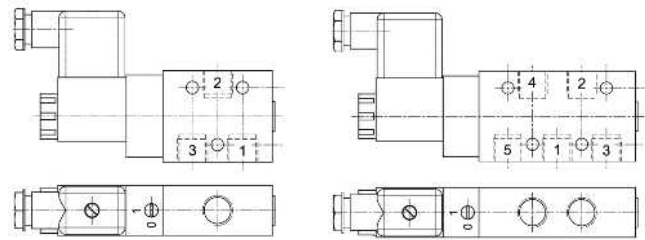

Fig. 1: Connector 8500

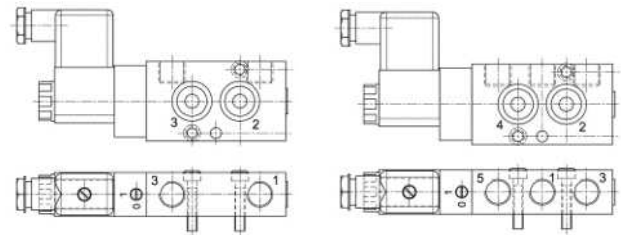
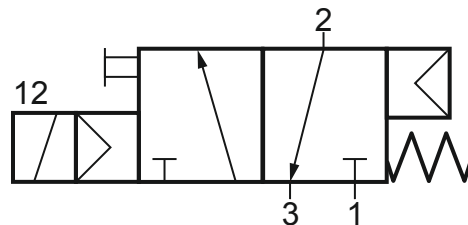
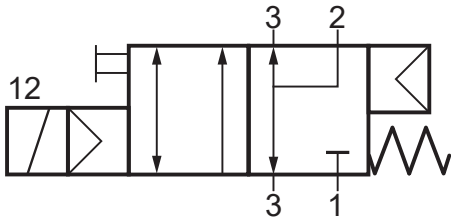

Fig. 2: Connector 8500N

Item	Name
1	Air supply
2	Output
3	Exhaust air
4	Output (for 5/2-way version only)
5	Exhaust air (for 5/2-way version only)

10.1 Circuit diagram**10.1.1 3/2-way standard**

10.1.2 3/2-way NAMUR



10.1.3 5/2-way standard and NAMUR

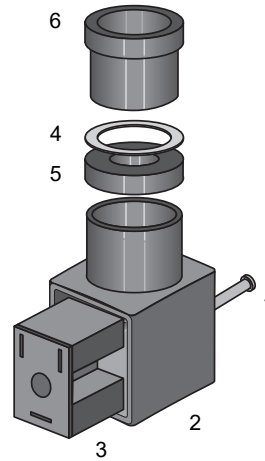
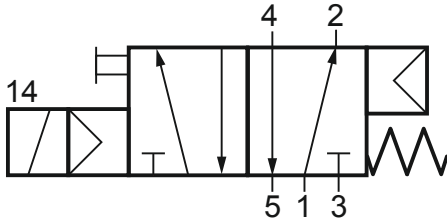

Fig. 3: Electrical connection

1. Disconnect the plant from power supply.
2. Unscrew retaining screw 1.
3. Pull off plug 2 with terminal block 3 from solenoid.
4. Press terminal block 3 carefully out of plug 2.
5. Unscrew cable entry 6.
6. Remove pressure ring 4 and gasket 5.
7. Insert cable through cable entry 6, pressure ring 4, gasket 5 and plug 2.
8. Connect the cable.

11 Electrical connection

⚠ DANGER

Risk of electric shock

- ▶ Risk of injury or death (if operating voltage is higher than safe extra low voltage).
- ▶ Electric shock can cause severe burns and fatal injury.
- Work on electrical connections only by qualified trained personnel.
- Disconnect the cable from the power supply before making the electrical connection.
- Connect the protective earth conductor.

NOTICE

- ▶ Every valve solenoid must have a fuse appropriate for its rated current (max. 3 times rated current in accordance with DIN 41571 or IEC 60127-2-1) or a motor protection switch with short circuit and thermal instantaneous trip (setting to rated current) connected upstream as protection against short circuits. This fuse may be located in the corresponding power supply unit or must be connected separately upstream. The fuse rated voltage must be equal to or greater than the specified nominal voltage of the solenoid. The breaking capacity of the fuse unit must be equal to or greater than the maximum short-circuit current occurring at the site of installation (usually 1500 A).

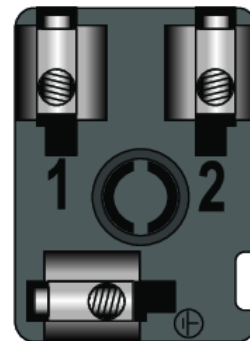

Fig. 4: Rear of terminal block

Item	Name
1	Supply voltage
2	Supply voltage
	Earthing

9. Push gasket **5** and pressure ring **4** into plug **2**.
10. Insert terminal block **3** again in the plug **2** until it audibly clicks in position.
11. Screw plug **2** to solenoid with retaining screw **1** (max. 0.3 Nm).
12. Tighten cable entry **6**.

11.1 Manual override

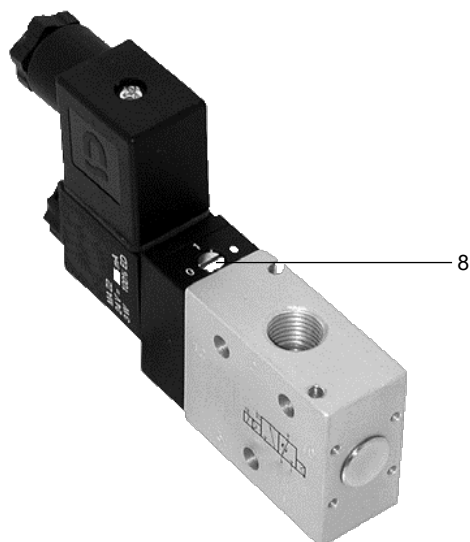

Fig. 5: Manual override

The pilot solenoid valves are equipped with a manual override **8**.

Only actuate the manual override in case of malfunction!

Actuate valve via manual override:

- Turn the rotary screw with a screw driver to position 1 (until it stops).

Close valve by manual override:

- Turn the rotary screw with a screw driver to position 0 (until it stops).

12 Interlinking system

12.1 3/2-way design

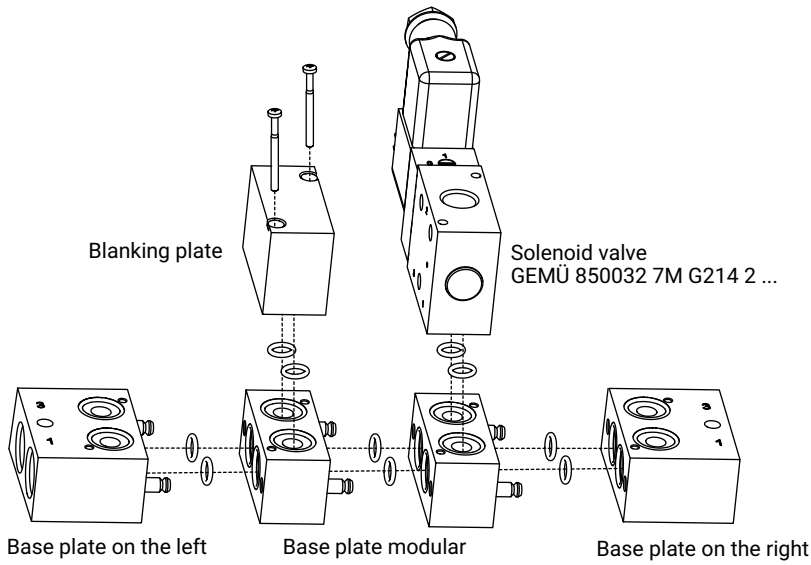

Designation	Item
Base plate on the right, 3/2-way	99115411
Base plate on the left, 3/2-way	99115412
Base plate modular, 3/2-way	99115413
Blanking plate	99115653

12.2 5/2-way design

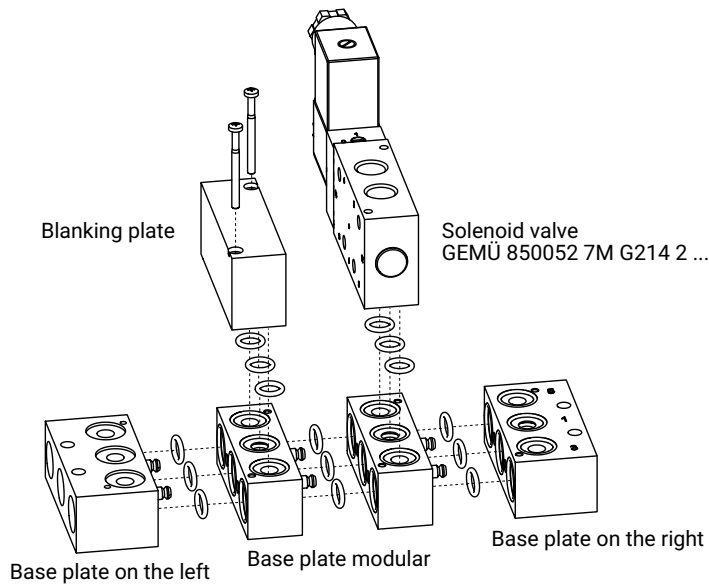

Designation	Item
Base plate on the right, 5/2-way	99115408
Base plate on the left, 5/2-way	99115409
Base plate modular, 5/2-way	99115410
Blanking plate	99115652

13 Commissioning

CAUTION



Protect against leakage!

- Check the tightness of the media connections prior to commissioning!
- Provide precautionary measures against exceeding the maximum permitted pressures caused by pressure surges.

Prior to cleaning or commissioning the plant:

1. Check the tightness and the function of the pilot solenoid valve.
2. If the plant is new or repair work has just taken place, blow out the piping system with a fully opened pilot solenoid valve (to remove any harmful foreign matter).

Cleaning

- The plant operator is responsible for selecting the cleaning medium and performing the procedure.

14 Fault clearance

Error	Error cause	Troubleshooting
No function	Power supply not OK	Check power supply and connection with product label
	Solenoid coil faulty	Check continuity, replace solenoid coil if necessary
	Operating pressure too high	Check operating pressure, reduce if necessary
	Control aperture contaminated	Clean pilot solenoid valve, fit strainer in front if necessary
	Armature blocked	Clean the armature and the bush
	Manual override in position 1	Unlock the manual override as described in chapter "Manual override"
Pilot solenoid valve leaking	Main valve seat leaking	Clean main valve seat

15 Inspection and maintenance

⚠ WARNING



Danger of burning from hot surfaces!

- ▶ Solenoid coil heats up during operation.
- Allow the solenoid coil and piping to cool down before servicing work.

⚠ WARNING

The equipment is subject to pressure!

- ▶ Risk of severe injury or death
- Depressurize the plant.
- Completely drain the plant.

1. Use appropriate protective gear as specified in plant operator's guidelines.
2. Shut off plant or plant component.
3. Secure against recommissioning.
4. Depressurize the plant or plant component.

NOTICE

- Only use genuine GEMÜ spare parts.
- When ordering spare parts, please state the complete order number of the pilot solenoid valve.

The operator must carry out regular visual examination of the valves dependent on the operating conditions and the potential danger in order to prevent leakage and damage. The valve also has to be checked for wear in the corresponding intervals.

15.1 Solenoid coil replacement

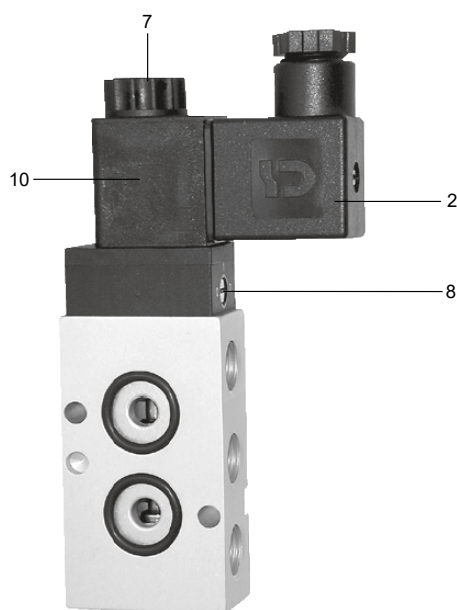

Fig. 6: Solenoid coil replacement

NOTICE

- ▶ When replacing the solenoid coil, the pilot solenoid valve cannot be operated electrically, but only manually via the manual override **8**.

1. Disconnect the plug **2** from power supply.
2. Undo the fastening nut **7**.
3. Pull the plug **2** off the solenoid coil **10**.
4. Place a new solenoid coil **10** on the bush.
5. Place the plug **2** back onto the solenoid coil **3**.
6. Tighten the fastening nut **7** manually.
7. Push the plug **2** and gasket onto the solenoid coil **10** and tighten with the fixing screw (60 Ncm).

16 Disassembly

Disassembly is performed observing the same precautionary measures as for installation.

1. Disassemble the pilot solenoid valve (see chapter "Installation").
2. Disconnect the pneumatic line(s) (see chapter "Pneumatic connection").
3. Disconnect the electric wire(s) (see chapter "Electrical connection").

17 Disposal

1. Pay attention to adhered residual material and gas diffusion from penetrated media.
2. Dispose of all parts in accordance with the disposal regulations/environmental protection laws.

Parts	Disposal
Valve bodies, valve covers	in accordance with material identification
Screws, armatures, bushes, compression springs	as metallic core scrap
O-rings, diaphragms, sealing and plastic parts	as domestic waste type commercial waste
Solenoid coil	as electrical scrap
Flex plate	in accordance with material identification

18 Returns

Legal regulations for the protection of the environment and personnel require that the completed and signed return delivery note is included with the dispatch documents. Returned goods can be processed only when this note is completed. If no return delivery note is included with the product, GEMÜ cannot process credits or repair work but will dispose of the goods at the operator's expense.

1. Clean the product.
2. Request a return delivery note from GEMÜ.
3. Complete the return delivery note.
4. Send the product with a completed return delivery note to GEMÜ.

19 Declaration of conformity according to 2014/68/EU (Pressure Equipment Directive)

EU Declaration of Conformity

in accordance with 2014/68/EU (Pressure Equipment Directive)

We, the company
GEMÜ Gebr. Müller Apparatebau GmbH & Co. KG
Fritz-Müller-Strasse 6-8
74653 Ingelfingen-Criesbach, Germany

declare that the product listed below complies with the safety requirements of the Pressure Equipment Directive 2014/68/EU.

Description of the pressure equipment: GEMÜ 8500
Notified body: TÜV Rheinland Industrie Service GmbH
Number: 0035
Certificate no.: 01 202 926/Q-02 0036
Conformity assessment procedure: Module H1
Technical standard used: EN 1983, AD 2000

Note for products with a nominal size \leq DN 25:

The products are developed and produced according to GEMÜ process instructions and quality standards which comply with the requirements of ISO 9001 and ISO 14001.

According to Article 4, Paragraph 3 of the Pressure Equipment Directive 2014/68/EU these products must not be identified by a CE-label.

2023-10-10



Joachim Brien
Head of Technical Department

20 Declaration of conformity in accordance with 2014/35/EU (Low Voltage Directive) and 2014/30/EU (EMC Directive)

EU Declaration of Conformity
in accordance with 2014/30/EU (EMC Directive) and 2014/35/EU (Low Voltage Directive)

We, the company GEMÜ Gebr. Müller Apparatebau GmbH & Co. KG
Fritz-Müller-Strasse 6-8
74653 Ingelfingen-Criesbach, Germany

declare that the product listed below complies with the directives named above.

Description of the product: GEMÜ 8500

2023-10-10



Joachim Brien
Head of Technical Department



GEMÜ Gebr. Müller Apparatebau GmbH & Co. KG
Fritz-Müller-Straße 6-8, 74653 Ingelfingen-Criesbach, Germany
Phone +49 (0) 7940 1230 · info@gemue.de
www.gemu-group.com

Subject to alteration

10.2023 | 88600727