

GEMÜ Q50 eSyStep

Positioner (Code S0, S5, S6)

Motorized pinch valve

EN

Operating instructions



All rights including copyrights or industrial property rights are expressly reserved.

Keep the document for future reference.

© GEMÜ Gebr. Müller Apparatebau GmbH & Co. KG
06.03.2023

Contents

1	General information	4
1.1	Information	4
1.2	Symbols used	4
1.3	LED symbols	4
1.4	Definition of terms	4
1.5	Warning notes	4
1.6	Safety information on the product	5
2	Safety information	5
3	Product description	6
3.1	Construction	6
3.2	LED displays	6
3.3	Description	6
3.4	Function	7
3.5	Product label	7
4	Correct use	7
5	Order data	8
6	Technical data	9
7	Electrical connection	13
8	Dimensions	17
9	Manufacturer's information	19
9.1	Delivery	19
9.2	Packaging	19
9.3	Transport	19
9.4	Storage	19
10	Installation	19
10.1	Preparing for installation	19
10.2	Installation position	19
10.3	Mounting without mounting flange	20
10.4	Mounting with mounting flange	20
11	Specific data IO-Link (pin 6)	21
11.1	Operation on IO-Link	21
11.2	Process data	24
11.3	Parameter overview	25
11.4	Parameter	29
11.5	Events	46
12	Operation	48
12.1	Initialization	48
12.2	Manual override	48
13	Inspection and maintenance	49
14	Troubleshooting	52
15	Removal	54
16	Disposal	54
17	Returns	54

1 General information

1.1 Information

- The descriptions and instructions apply to the standard versions. For special versions not described in this document the basic information contained herein applies in combination with any additional special documentation.
- Correct installation, operation, maintenance and repair work ensure faultless operation of the product.
- Should there be any doubts or misunderstandings, the German version is the authoritative document.
- Contact us at the address on the last page for staff training information.

1.2 Symbols used

The following symbols are used in this document:

Symbol	Meaning
●	Tasks to be performed
▶	Response(s) to tasks
-	Lists

1.3 LED symbols

The following LED symbols are used in the documentation:

Symbol	LED conditions
○	Off
●	Lit (on)
☼	Flashing

1.4 Definition of terms

Working medium

The medium that flows through the tube.

1.5 Warning notes

Wherever possible, warning notes are organised according to the following scheme:

SIGNAL WORD	
Possible symbol for the specific danger	<p>Type and source of the danger</p> <ul style="list-style-type: none"> ▶ Possible consequences of non-observance. ● Measures for avoiding danger.

Warning notes are always marked with a signal word and sometimes also with a symbol for the specific danger.

The following signal words and danger levels are used:





⚠ DANGER	
	<p>Imminent danger!</p> <ul style="list-style-type: none"> ▶ Non-observance can cause death or severe injury.

⚠ WARNING	
	<p>Potentially dangerous situation!</p> <ul style="list-style-type: none"> ▶ Non-observance can cause death or severe injury.

⚠ CAUTION	
	<p>Potentially dangerous situation!</p> <ul style="list-style-type: none"> ▶ Non-observance can cause moderate to light injury.

NOTICE	
	<p>Potentially dangerous situation!</p> <ul style="list-style-type: none"> ▶ Non-observance can cause damage to property.

The following symbols for the specific dangers can be used within a warning note:

Symbol	Meaning
	Danger of explosion!
	Corrosive chemicals!
	Hot plant components!
	Risk of crushing!
	Risk of crushing due to the compressor shutting down!

1.6 Safety information on the product

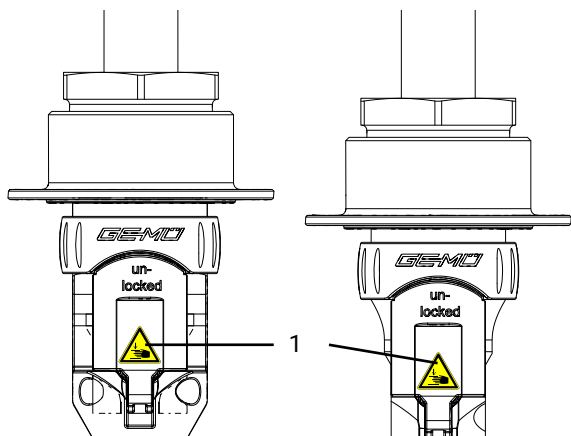

Item	Symbol	Meaning
1		Risk of crushing! - Do not reach into the tube crushing area.

Missing or illegible adhesive labels on the product must be attached or replaced.

2 Safety information

The safety information in this document refers only to an individual product. Potentially dangerous conditions can arise in combination with other plant components, which need to be considered on the basis of a risk analysis. The operator is responsible for the production of the risk analysis and for compliance with the resulting precautionary measures and regional safety regulations.

The document contains fundamental safety information that must be observed during commissioning, operation and maintenance. Non-compliance with these instructions may cause:

- Personal hazard due to electrical, mechanical and chemical effects.
- Hazard to nearby equipment.
- Failure of important functions.
- Hazard to the environment due to the leakage of dangerous substances.

The safety information does not take into account:

- Unexpected incidents and events, which may occur during installation, operation and maintenance.
- Local safety regulations which must be adhered to by the operator and by any additional installation personnel.

Prior to commissioning:

1. Transport and store the product correctly.
2. Do not paint the screws and plastic parts of the product.
3. Carry out installation and commissioning using trained personnel.
4. Provide adequate training for installation and operating personnel.
5. Ensure that the contents of the document have been fully understood by the responsible personnel.
6. Define the areas of responsibility.
7. Observe the safety data sheets.
8. Observe the safety regulations for the media used.

During operation:

9. Keep this document available at the place of use.
10. Observe the safety information.
11. Operate the product in accordance with this document.
12. Operate the product in accordance with the specifications.
13. Maintain the product correctly.
14. Do not carry out any maintenance work and repairs not described in this document without consulting the manufacturer first.

In cases of uncertainty:

15. Consult the nearest GEMÜ sales office.

3 Product description

3.1 Construction

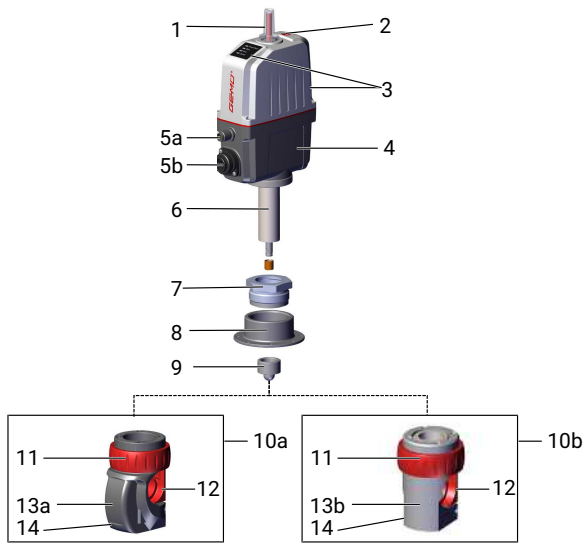

Item	Name	Materials
1	Optical position indicator	PA 12
2	Manual override	
3	Actuator top with LED display	Polyamide, 50% glass fibre
4	Actuator base	Polyamide, 50% glass fibre
5a	Electrical connection X2 (only for positioner design)	
5b	Electrical connection X1	
6	Distance piece	Stainless steel
7	Union nut	Stainless steel
8	Distance piece with mounting flange including EPDM seal	Stainless steel
9	Compressor	Stainless steel
10a	Valve body	PA6
10b	Valve body	Stainless steel/PA6
11	Locking ring	PA6
12	Tube holder	PA6
13a	Tube carrier	PA6
13b	Tube carrier	Stainless steel
14	CONEXO RFID chip	

3.2 LED displays

3.2.1 Status LEDs

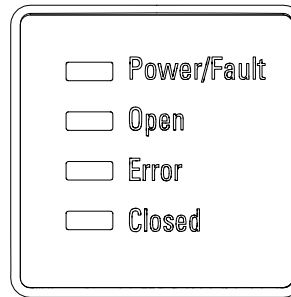

LED	Colour		Function
	Standard	Inversed ¹⁾	
Power/fault	green	green	Operating indication/communication status
	red	red	
Open	orange	green	Process valve in OPEN position
Error	red	red	Error
Closed	green	orange	Process valve in CLOSED position

1) Inversed representation of the OPEN and CLOSED LEDs, adjustable via IO-Link

3.2.2 LED conditions

Status process valve	Power/fault	Open	Error	Closed
OPEN position	●	●	○	○
CLOSED position	●	○	○	●
Position unknown	●	○	○	○
Initialization	●	☀	○	☀
		Open and Closed flash alternately		

LED conditions					
●	lit (on)	☀	flashes	○	off

3.3 Description

The GEMÜ Q50 eSyStep 2/2-way pinch valve is motorized. The eSyStep actuator is designed as an actuator with integrated positioner. The valve guides a tube which is compressed from above by a compressor to control and regulate media. The compressor's specially developed contour and the tube holder's contour minimize the strain on the tube and thus increase the tubes' service life. Tubes can be safely inserted and removed in simple steps and without tools. An optical and electrical position indicator is integrated as standard.

3.4 Function

The product controls or regulates (depending on version) a flowing medium by being closed or opened by a motorized actuator.

The product is equipped as standard with a mechanical position indicator as well as an electrical position and status indicator.

3.5 Product label

The product label is located on the actuator. Product label data (example):

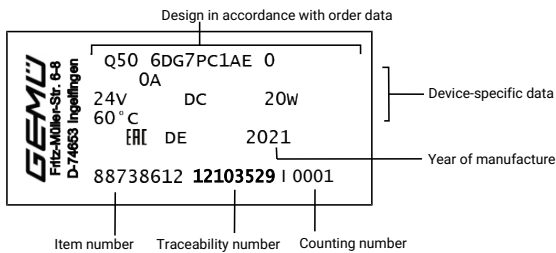

The month of manufacture is encoded in the traceability number and can be obtained from GEMÜ. The product was manufactured in Germany.

4 Correct use

DANGER



Danger of explosion!

- ▶ Risk of death or severe injury
- Do **not** use the product in potentially explosive zones.

WARNING

Improper use of the product!

- ▶ Risk of severe injury or death
- ▶ Manufacturer liability and guarantee will be void
- Only use the product in accordance with the operating conditions specified in the contract documentation and in this document.

NOTICE

Suitability of the product.

- ▶ The product must be appropriate for the tube's operating conditions (medium, medium concentration, temperature and pressure) and the respective ambient conditions.

The product is designed to control a working medium guided in a tube.

The product is not intended for use in potentially explosive areas.

- Use the product in accordance with the technical data.

5 Order data

The order data provide an overview of standard configurations.

Please check the availability before ordering. Other configurations available on request.

Order codes

1 Type	Code
Pinch valve, electrically operated, eSyStep	Q50

2 Tube inside diameter	Code
3.180 mm (1/8") inside diameter	2
6.350 mm (1/4") inside diameter	4
9.530 mm (3/8") inside diameter	6
12.700 mm (1/2") inside diameter	8

3 Tube outside diameter	Code
6.350 mm (1/4") outside diameter	DA
9.530 mm (3/8") outside diameter	DC
11.110 mm (7/16") outside diameter	DD
12.700 mm (1/2") outside diameter	DE
15.880 mm (5/8") outside diameter	DG
19.100 mm (3/4") outside diameter	DH
22.230 mm (7/8") outside diameter	DI

4 Tube carrier version	Code
Plastic design, stainless steel tube carrier and PA tube holder	7P
Plastic design, PA tube carrier and PA tube holder	PA

5 Voltage/Frequency	Code
24 V DC	C1

6 Control module	Code
OPEN/CLOSE control, additional end position indicators, configured for emergency power supply module (NC)	A5
OPEN/CLOSE control, additional end position indicators, configured for emergency power supply module (NO)	A6
OPEN/CLOSE control, additional end position indicators	AE
Positioner	S0
Positioner, configured for emergency power supply module (NC)	S5
Positioner, configured for emergency power supply module (NO)	S6

7 Mounting option	Code
Without mounting flange, with 4 x threaded hole in body	0
With mounting flange above	FT

8 Actuator version	Code
Actuator size 0	0A

9 CONEXO	Code
Without	
Integrated RFID chip for electronic identification and traceability	C

Order example

Ordering option	Code	Description
1 Type	Q50	Pinch valve, electrically operated, eSyStep
2 Tube – inside diameter	8	12.700 mm (1/2") inside diameter
3 Tube – outside diameter	DH	19.100 mm (3/4") outside diameter
4 Valve body material	7P	Plastic design, stainless steel tube carrier and PA tube holder
5 Voltage/frequency	C1	24 V DC
6 Control module	S0	Positioner
7 Mounting flange	FT	With mounting flange above
8 Actuator version	0A	Actuator size 0
9 CONEXO		Without

6 Technical data

6.1 Medium

Working medium: Please observe the tube manufacturer's specifications

6.2 Temperature

Media temperature: Please observe the tube manufacturer's specifications

Ambient temperature: Actuator: 0 – 60 °C, Tube: Please observe the tube manufacturer's specifications

Storage temperature: 0 – 40 °C

6.3 Pressure

Operating pressure: max. 6 bar ,
Please observe the tube manufacturer's specifications

6.4 Product compliance

Machinery Directive: 2006/42/EC

EMC Directive: 2014/30/EU

Technical standards used:

Interference emission DIN EN 61000-6-4 (07/2011)
 DIN EN 61326-1 (industry) (07/2013)
 Interference emission class: Class A
 Interference emission group: Group 1

Interference resistance DIN EN 61000-6-2 (03/2006)
 DIN EN 61326-1 (industry) (07/2013)

6.5 Mechanical data

Protection class: IP 65 acc. to EN 60529

Mechanical environmental conditions: Class 4M8 acc. to EN 60721-3-4:1998

Vibration: 5g acc. to IEC 60068-2-6 Test Fc

Shock: 25g acc. to 60068-2-27 Test Ea

6.6 Actuator's duty cycle and service life

If there is inadequate force to compress the tube, the force of the actuator can be adapted via the IO-Link using the config files.

Service life: **Control operation** - Class C according to EN 15714-2 (1,800,000 starts and 1200 starts per hour).
Open/Close duty - At least 500,000 switching cycles at room temperature and permissible duty cycle.

Duty cycle: Control module Positioner (code S0, S5, S6), Open/Close duty

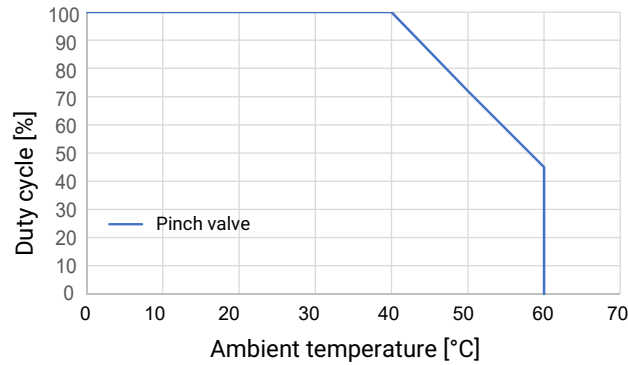

NOTICE

- ▶ The specified characteristics and values apply to the default setting.
- ▶ With reduced forces, higher duty cycles and/or higher ambient temperatures are possible. At higher force settings the duty cycle and/or ambient temperature is reduced.
- ▶ IO-Link: Index 0x90 - Subindex 2 - Force

6.7 Electrical data

Supply voltage Uv: 24 V DC ± 10%

Rating: Actuator size 0 (code 0A) 20 W

Operation: Stepper motor, self-locking

Reverse battery protection: Yes

6.7.1 Analogue input signals – Control module Positioner (code S0, S5, S6)

6.7.1.1 Set value

Input signal: 0/4 - 20 mA; 0 - 10 V (function selectable via IO-Link)

Input type: passive

Input resistance: 250 Ω

Accuracy/linearity: ≤ ±0.3% of full flow

Temperature drift: ≤ ±0.1% / 10°K

Resolution: 12 bit

Reverse battery protection: Yes (up to ± 24 V DC)

6.7.2 Digital input signals

Inputs:	Function selectable via IO-Link (see table Overview of available functions – Input and output signals)
Input voltage:	24 V DC
Logic level "1":	> 15.3 V DC
Logic level "0":	< 5.8 V DC
Input current:	typically < 0.5 mA

6.7.3 Analogue output signals – Control module Positioner (code S0, S5, S6)**6.7.3.1 Actual value**

Output signal:	0/4 - 20 mA; 0 - 10 V (function selectable via IO-Link)
Output type:	active
Accuracy:	≤ ±1% of full flow
Temperature drift:	≤ ±0.1% / 10°K
Load resistor:	≤ 750 kΩ
Resolution:	12 bit
Short-circuit proof:	Yes

6.7.4 Digital output signals

Outputs:	Function selectable via IO-Link (see table Overview of available functions – Input and output signals)
Type of contact:	Push-Pull
Switching voltage:	Power supply U_v
Switching current:	≤ 140 mA
Short-circuit proof:	Yes

6.7.5 Communication

Interface:	IO-Link
Function:	Parameterization/process data
Transmission rate:	38400 baud
Frame type in Operate:	2.V (eSyStep positioner, code S0, S5, S6), PDout 3Byte; PDin 3 Byte; OnRequestData 2 Byte
Min. cycle time:	20 ms (eSyStep positioner, code S0, S5, S6)
Vendor-ID:	401
Device-ID:	1906801 (eSyStep positioner, code S0, S5, S6),
Product-ID:	eSyStep Positioner (code S0, S5, S6)

ISDU support: Yes

SIO operation: Yes

IO-Link specification: V1.1

IODD files can be downloaded via <https://ioddfinder.io-link.com/> or www.gemu-group.com.

7 Electrical connection

NOTICE

Appropriate cable socket/appropriate mating connector

- ▶ The appropriate connectors are included for X1 and X2.

7.1 Position of the connectors

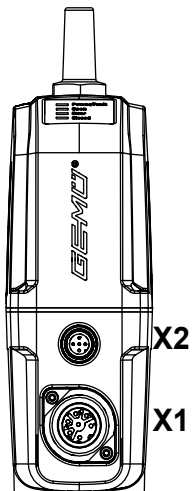

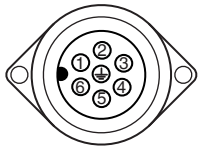
7.2 Connection X1

7-pin plug, Binder, type 693

Pin	Signal name
1	Uv, 24 V DC supply voltage
2	GND
3	Digital input 1
4	Digital input 2
5	Digital input/output
6	Digital output, IO-Link
7	n.c.

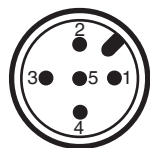
7.3 Connection X2 (only for positioner design)

5-pin M12 plug, A-coded

Pin	Signal name
1	I+/U+, set value input
2	I-/U-, set value input
3	I+/U+, actual value output
4	I-/U-, actual value output
5	n.c.

7.4 Overview of available functions – Input and output signals

NOTICE

- ▶ The factory default setting "Configured for emergency power supply module" is reset to default settings when a reset is carried out.

NOTICE

- ▶ When the digital inputs for OPEN and CLOSE are activated simultaneously, the defined error position is approached.

	Function	Control module S0	Control module S5, S6
		Default settings	Factory default setting "Configured for emergency power supply module"
Digital input 1	Off/Open/Closed/Safe/On/Initialization	Initialization	Initialization
Digital input 2	Off/Open/Closed/Safe/On/Initialization	Off	Safe/On
Digital input/output	Open/Closed/Error/Error and warning/Initialization	Error	Error
Digital output	Open/Closed/Error/Error and warning	Closed	Closed
Analogue input	4–20 mA/0–20 mA/0–10 V	4–20 mA	4–20 mA
Analogue output	4–20 mA/0–20 mA/0–10 V	4–20 mA	4–20 mA

7.5 Connection diagram

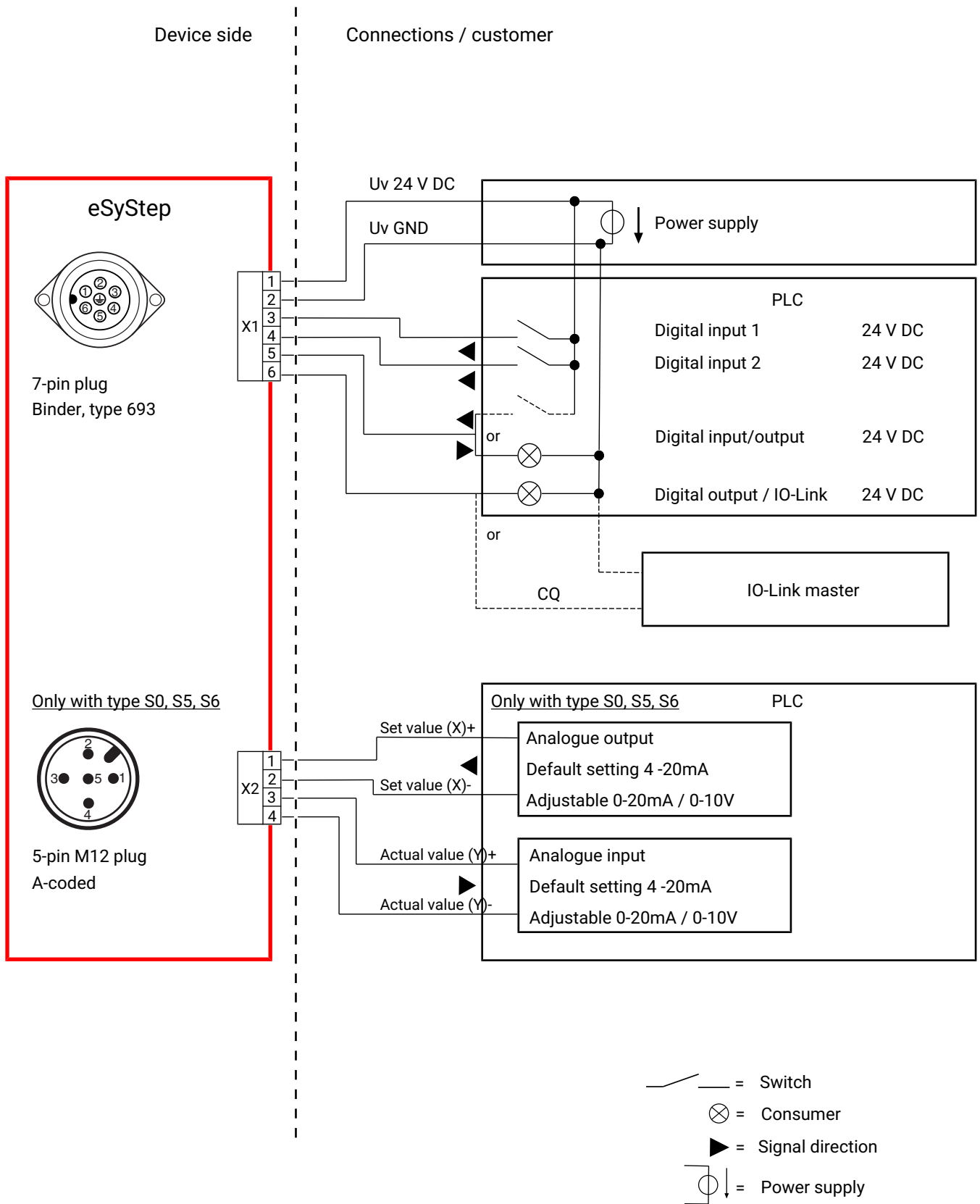

8 Dimensions

8.1 Actuator for tube outside diameter $\leq 1/2''$

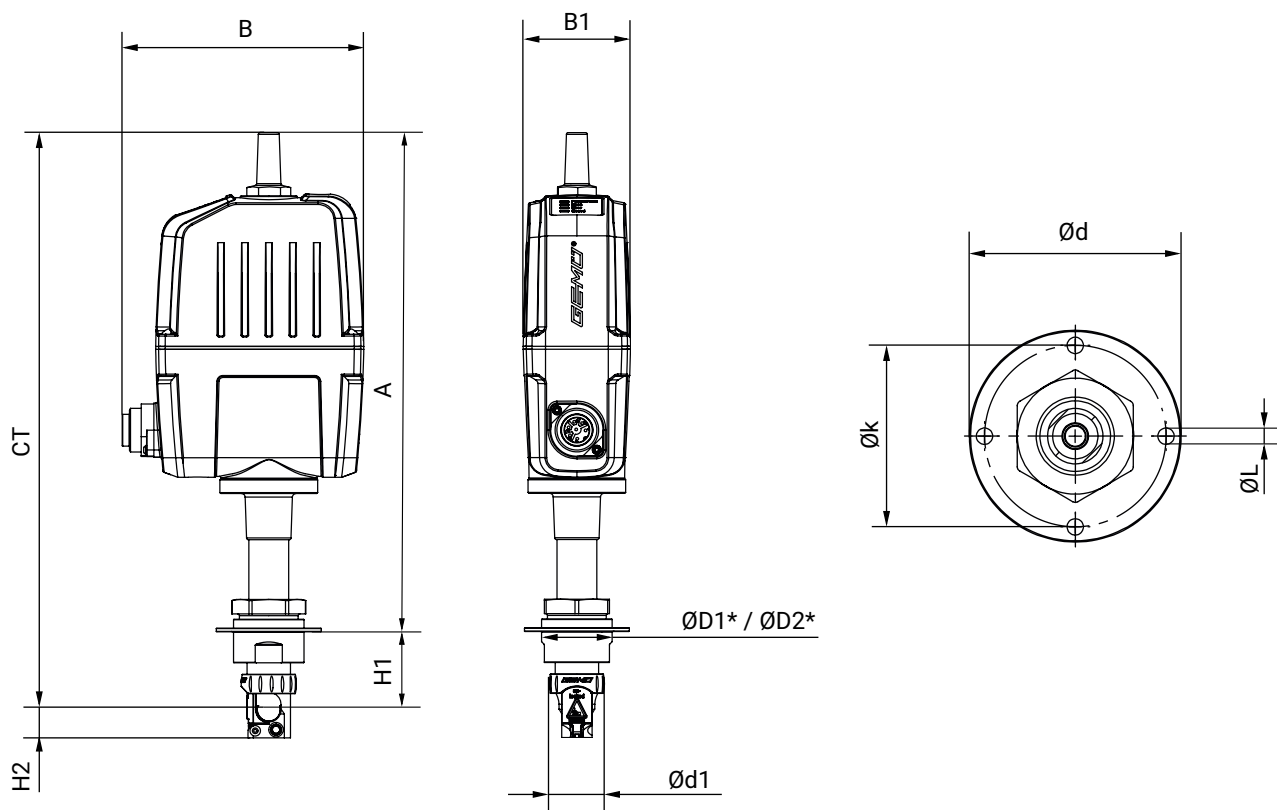

A	B	B1	CT	ØD1*	ØD2*	Ød	Ød1	H1	H2	Øk	ØL
275.9	133.5	59.4	318.9	39.0	42.0	58.0	30.5	43.0	15.6	49.0	4.5

Dimensions in mm

* D1 = diameter without seal, D2 = diameter with seal

8.2 Actuator for tube outside diameter $\geq 5/8"$

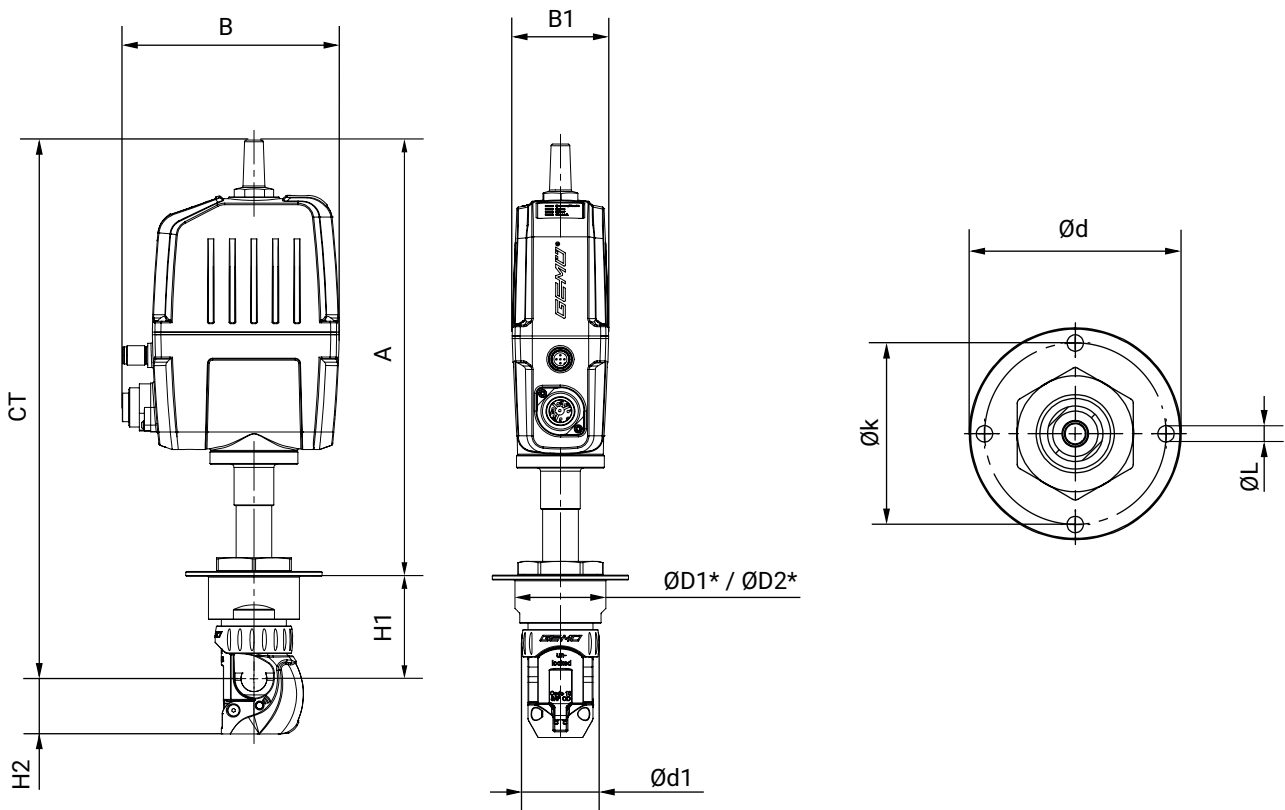

A	B	B1	CT	ØD1*	ØD2*	Ød	Ød1	H1	H2	Øk	ØL
235.0	133.5	59.4	332.0	56.0	60.0	84.0	47.8	63.0	34.0	72.0	6.5

Dimensions in mm

* D1 = diameter without seal, D2 = diameter with seal

8.3 Valve body, without mounting flange

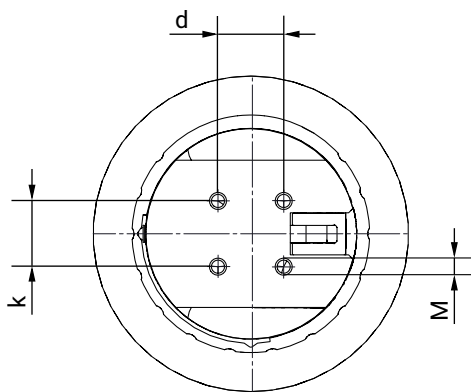

Tube outside diameter	d	k	M
$\leq 1/2"$	7.0	7.0	M2
$\geq 5/8"$	12.0	12.0	M4

Dimensions in mm

9 Manufacturer's information

9.1 Delivery

- Check that all parts are present and check for any damage immediately upon receipt.

The product's performance is tested at the factory. The scope of delivery is apparent from the dispatch documents and the design from the order number.

9.2 Packaging

The product is packaged in a cardboard box which can be recycled as paper.

9.3 Transport

1. Only transport the product by suitable means. Do not drop. Handle carefully.
2. After the installation dispose of transport packaging material according to relevant local or national disposal regulations / environmental protection laws.

9.4 Storage

1. Store the product free from dust and moisture in its original packaging.
2. Avoid UV rays and direct sunlight.
3. Do not exceed the maximum storage temperature (see chapter "Technical data").
4. Do not store solvents, chemicals, acids, fuels or similar fluids in the same room as GEMÜ products and their spare parts.

10 Installation

10.1 Preparing for installation

WARNING

The equipment is subject to pressure!

- ▶ Risk of severe injury or death
- Depressurize the plant.
- Completely drain the plant.

WARNING



Corrosive chemicals!

- ▶ Risk of caustic burns
- Wear appropriate protective gear.
- Completely drain the plant.

CAUTION



Hot plant components!

- ▶ Risk of burns
- Only work on plant that has cooled down.

CAUTION

Use as step.

- ▶ Damage to the product
- ▶ Risk of slipping-off
- Choose the installation location so that the product cannot be used as a foothold.
- Do not use the product as a step or a foothold.

NOTICE

Suitability of the product.

- ▶ The product must be appropriate for the tube's operating conditions (medium, medium concentration, temperature and pressure) and the respective ambient conditions.

NOTICE

Requirements for tube lines used!

- ▶ Use tube lines suitable for the application, see manufacturer's information.
- Only use undamaged tube lines.

NOTICE

Lay tube lines professionally!

- ▶ Lay tube lines professionally and do not bend them below the minimum bending radius, see manufacturer's information.
- Do not kink or twist the tube lines.

NOTICE

Tools

- ▶ The tools required for installation and assembly are not included in the scope of delivery.
- Use appropriate, functional and safe tools.

1. Ensure the product is suitable for the relevant application.
2. Check the technical data of the product and the materials.
3. Keep appropriate tools ready.
4. Use appropriate protective gear as specified in plant operator's guidelines.
5. Observe appropriate regulations for connections.
6. Installation work must be performed by trained personnel.
7. Shut off plant or plant component.
8. Secure the plant or plant component against recommissioning.
9. Depressurize the plant or plant component.
10. Completely drain the plant or plant component and allow it to cool down until the temperature is below the media vaporization temperature and cannot cause scalding.
11. Pay attention to the installation position (see chapter "Installation position").

10.2 Installation position

The installation position of the product is optional.

10.3 Mounting without mounting flange

1. Before mounting the valve body, machine the housing in accordance with the borehole pattern in the chapter "Dimensions" so that the valve body can be secured to the housing.
2. Secure the valve body to the housing using four screws.
3. Re-attach or reactivate all safety and protective devices.

10.4 Mounting with mounting flange

1. Before mounting the actuator, machine the housing in accordance with the borehole pattern in the chapter "Dimensions" so that the valve body can be guided through the recess.
2. Guide the valve body through the recess in the housing. The actuator's mounting flange must be flush with the housing.
3. Connect the mounting flange and housing using appropriate screws and washers (not included in the scope of delivery).

11 Specific data IO-Link (pin 6)

IO-Link process data and parameters can be set via pin 6 for the motorized linear actuator eSyStep. The assignment of the connectors and the current consumption of the actuator are non-compliant with the IO-Link specification.

11.1 Operation on IO-Link

11.1.1 Operation on PLC as a 24 V device

The motorized actuator GEMÜ eSyStep can be operated directly in a PLC control unit without limitations. Technical data of the product and of PLC must be complied with.

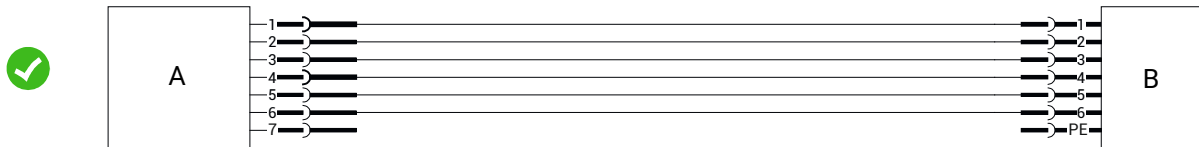

Item	Name
A	eSyStep
B	PLC with supply voltage

11.1.2 Operation on PLC and additional parameterization via USB master with galvanic isolation

Basics

When operating the product on a PLC control unit, a parameterization via a USB IO-Link master is possible at the same time. In this case, a galvanically isolated USB interface must be used. The PC/laptop can be used as usual and all peripheral devices can remain connected.

Connection

1. Connect **pin 3 (L-)** of the master with **pin 2 (GND)** of the product.
2. Connect **pin 4 (CQ)** of the master with **pin 6** of the product.

During IO-Link operation, pin 6 **cannot** be evaluated by the PLC control unit as an output signal.

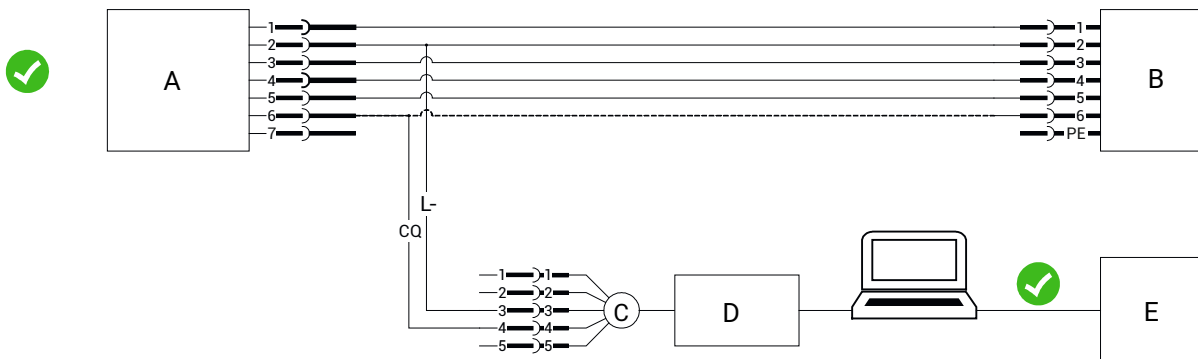

Item	Name
A	eSyStep
B	PLC with supply voltage
C	USB IO-Link Master
D	Galvanically isolated USB interface
E	Mains plug – laptop

11.1.3 Operation on PLC and additional parameterization via USB master without galvanic isolation

Basics

Only one laptop can be used if no galvanic isolation is available for the USB interface during communication via a USB IO-Link master. No other peripheral devices may be connected to the laptop. The laptop may only be operated without a power supply unit.

If further peripheral devices and the power supply unit are not disconnected, different ground potentials to the product can result in excessive compensating currents. These can damage the USB interface of the laptop, the connected peripheral devices or the USB IO-Link master.

Connection

1. Connect **pin 3 (L-)** of the master with **pin 2 (GND)** of the product.
2. Connect **pin 4 (CQ)** of the master with **pin 6** of the product.

During IO-Link operation, pin 6 **cannot** be evaluated by the PLC control unit as an output signal.

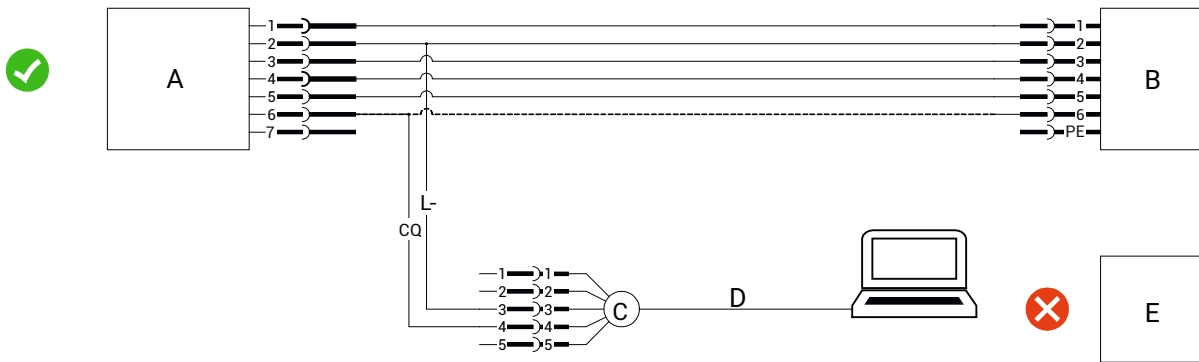

Item	Name
A	eSyStep
B	PLC with supply voltage
C	USB IO-Link Master
D	USB interface
E	Mains plug – laptop

11.1.4 Direct operation on the IO-Link master

Basics

If the product is to be operated on an IO-Link master, it must be ensured that the **GND** levels in the product and in the IO-Link master have the same potential so that there are no compensating currents which would cause damage in the system. This can be made possible using several procedures.

11.1.4.1 Identical power supply

The IO-Link master is operated from the same power supply as the product.

- Connect **pin 4 (CQ)** of the master with **pin 6** of the product.

However, **pin 3 (L-)** of the master should **not** be connected to **pin 2 (GND)** of the product under any circumstances.

This prevents a ground loop and no unexpected high currents can occur via **pin 3 (L-)** which can damage the master.

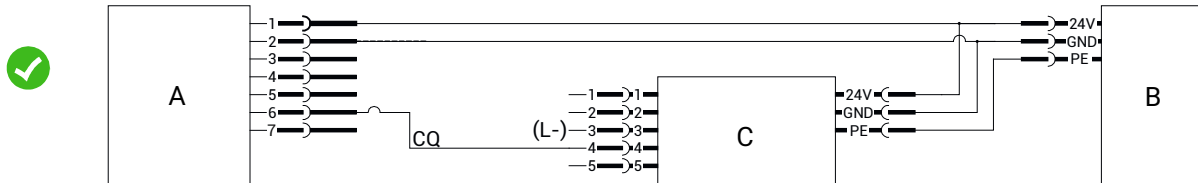

Item	Name
A	eSyStep
B	Supply voltage
C	USB IO-Link Master

11.1.4.2 Separate power supply, GND-connected

The IO-Link master and the product can also be operated with different power supply sources if the **GND** of both power supply sources is connected. In this case, the master is connected as when the power supply is identical

- Connect **pin 4 (CQ)** IO-Link master with **pin 6** of the product.

Do **not** connect (**pin 3**) L- IO-Link master.

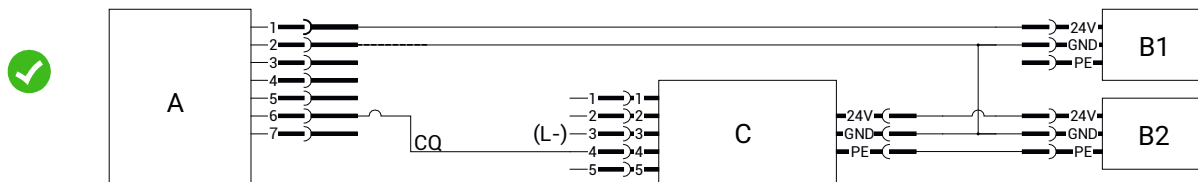

Item	Name
A	eSyStep
B1 and B2	Supply voltages
C	USB IO-Link Master

11.2 Process data

The motorized linear actuator has access to process data via the IO-Link. This is transmitted in cycles with every IO-Link telegram.

Master → Device

Name	Bit	Values
Drive go Open	0	0 → Actuator does not move into position Open
		1 → Actuator moves into position Open
Drive go Close	1	0 → Actuator does not move into position Closed
		1 → Actuator moves into position Closed
Start initialization	2	0 → No initialization
		1 → Start initialization
Locate	3	0 → Off
		1 → On
Setpoint analog	8 ... 23	Setpoint in the range 0 ... 1000

Device → Master

Name	Bit	Values
Valve position Open	0	0 → Process valve not in Open position
		1 → Process valve in Open position
Valve position Close	1	0 → Process valve not in Closed position
		1 → Process valve in Closed position
Operating mode	2	0 → Normal operation
		1 → Initialization mode
Valve position analog	8 ... 23	Position of the valve in the range 0 ... 1000

11.3 Parameter overview

NOTICE

► All IO-Link parameters that contain sub-indexes can also be addressed in bundles via sub-index 0.

Index	Sub-Index	Access rights	Index name	Parameter	Function	Factory settings	Setting options
0x02	0	W	System command		Transmission of commands for block parameterization and data storage		0x01 to 0x06 0x82
0x03	1	R/W	Data storage index	Data storage cmd	Saving and restoring parameter data for device identical in construction		
	2	RO		State property			
	3	RO		Data storage size			
	4	RO		Parameter checksum			
	5	RO		Index list			
0x0C	1	R/W	Device access locks	Parameter (write) access	Parameter write protection		0 → unlocked 1 → locked
	2	R/W		Data storage	Data memory		0 → unlocked 1 → locked
	3	R/W		Local parameterization	Local parameterization		0 → unlocked 1 → locked
	4	R/W		Local user interface	Local user interface		0 → unlocked 1 → locked
0x0D	0	RO	Profile characteristics		Supported Device Profile IDs, Common Application Profile IDs, Function Class IDs	0x8000 (Device Ident. Objects) 0x8002 (Process Data Mapping) 0x8003 (Diagnosis) 0x8100 (Ext. Identification)	
0x0E	0	RO	Process data input descriptor		Data format of input process data		0x00 (Bit offset) 0x03 (Type Length) 0x01 (DataType -> BoolT)
0x0F	0	RO	Process data output descriptor		Data format of output process data		0x00 (Bit offset) 0x04 (Type Length) 0x01 (DataType -> BoolT)
0x10	0	RO	Vendor name		Read out manufacturer name		"GEMUE"
0x12	0	RO	Product name		Read out device name		"eSyStep Positioner"
0x13	0	RO	Product ID		Read out product ID		"eSyStep Positioner"
0x15	0	RO	Serial number		Read out serial number		"XXXXXXXX/YYYY"
0x16	0	RO	Hardware revision		Read out hardware version		"Rev. XX/XX"
0x17	0	RO	Firmware revision		Read out software version		"V X.X.X.X."

Index	Sub-Index	Access rights	Index name	Parameter	Function	Factory settings	Setting options
0x18	0	R/W	Application specific tag		Text with 32 characters can be entered		„*****“
0x19	0	R/W	Function tag		Text with 32 characters can be entered		„*****“
0x1A	0	R/W	Location tag		Text with 32 characters can be entered		„*****“
0x24	0	RO	Device status		(Simple) device status		0 → Operating properly 2 → Out of specification 4 → Failure
0x25	0	RO	Device status		Detailed device status		
0x40	0	RO	Actuator size		Read out actuator size	Depending on the actuator size used	0 → Actuator size 0 1 → Actuator size 1 2 → Actuator size 2
0x4B	1	R/W	Function digital inputs	Input 1	Configure digital input 1	4	0 → Off 1 → Open 2 → Close 3 → Safe/On 4 → Init
	2	R/W		Input 2	Configure digital input 2	0	0 → Off 1 → Open 2 → Close 3 → Safe/On 4 → Init
0x4C	1	R/W	Function digital in-/output 1	In- / output 1	Configure digital inputs/outputs	2	0 → Output open 1 → Output close 2 → Output error 3 → Output Error & warning 4 → Input init
	2	R/W		Type in- / output 1	Configure type of digital inputs/outputs	0	0 → Push-pull 1 → NPN 2 → PNP
0x4D	0	R/W	Function digital output 2		Configure digital output	1	0 → Output open 1 → Output close 2 → Output error 3 → Output error & warning
0x4E	1	R/W	Logic digital inputs / outputs	Input 1	Configure logical digital input 1	0	0 → Active high 1 → Active low
	2	R/W		Input 2	Configure logical digital input 2	0	0 → Active high 1 → Active low
	3	R/W		Input / output 1	Configure logical digital input/output	0	0 → Active high 1 → Active low
	4	R/W		Output 2	Configure logical digital output	0	0 → Active high 1 → Active low

Index	Sub-Index	Access rights	Index name	Parameter	Function	Factory settings	Setting options
0x4F	1	R/W	Error action	Error action	Set safety position	2	0 → Hold 1 → Open 2 → Close
	2	R/W		Error time	Determine time from error detection to error message	1 (0.1s)	1 ... 1000 (0.1s ... 100s)
0x50	1	R/W	Basic settings	Inversion of LED colours	Activate / deactivate inversion of LEDs	0	0 → Standard 1 → Inversed
	2	R/W		On site initialization	Activate / deactivate on site initialization	0	0 → Enabled 1 → Disabled
	3	R/W		Operating mode	Operating mode change-over (positioner; ON/OFF)	0	0 → Positioner 1 → On/Off
	4	R/W		IO-Link process data	Activate/deactivate use of IO-Link process data	0	0 → Disabled 1 → Enabled
0x51	1	R/W	Actuator position feedback	Open request	Request valve position OPEN	900 (90.0%)	30 ... 970 (3.0 ... 97.0%)
	2	R/W		Close request	Request valve position CLOSED	100 (10.0%)	30 ... 970 (3.0 ... 97.0%)
	3	RO		Open real	Real valve position OPEN		0 ... 4095
	4	RO		Close real	Real valve position CLOSED		0 ... 4095
0x53	1	RO	Initialized positions	Open	Analog value valve position OPEN		0 ... 4095
	2	RO		Close	Analog value valve position CLOSED		0 ... 4095
	3	RO		Stroke	Read out the analog value for stroke (difference between OPEN and CLOSED).		0 ... 4095
0x55	1	RO	Calibrated positions	Max.	OPEN end position		0 ... 4095
	2	RO		Min.	CLOSED end position		0 ... 4095
0x60	1	RO	Analog values	Potentiometer	Analog value potentiometer		0 ... 4095
	2	RO		Supply voltage	Analog value supply voltage		0 ... 4095
	3	RO		Temperature	Analog value temperature sensor		0 ... 4095
	4	RO		Set value (W)	Analog value set value signal		0 ... 4095
0x62	1	RO	Operating times	Open	Operating time OPEN	0	0 to 255 (0 to 25.5s)
	2	RO		Close	Operating time CLOSE	0	0 to 255 (0 to 25.5s)
0x90	2	R/W	Drive sets	Force	Force, dependent on valve used		1 ... 6

Index	Sub-Index	Access rights	Index name	Parameter	Function	Factory settings	Setting options
	3	R/W		Force initialization	Force during initialization, dependent on valve used		1 ... 6
0xB0	1	R/W	Control parameters	P amplification	P component – positioner	200	1 ... 200 (0.1 ... 20.0)
	2	R/W		D amplification	D component – positioner	10	1 ... 200 (0.1 ... 20.0)
	3	R/W		Derivative time	Delay constant	0	0 to 100 (0 to 100 s)
	4	R/W		Dead band	Permissible system deviation	10	1 ... 250 (0.1 ... 25.0 %)
0xB2	1	R/W	Open / close tight	Open tight	Sealing function valve position OPEN	995	800 ... 1000 (80.0 ... 100.0 %)
	2	R/W		Close tight	Sealing function valve position CLOSED	5	0 ... 200 (0 ... 20.0 %)
0xB4	1	R/W	Split range	Split start	Set set value start	0	0 to Split End – 100 (0.0 to Split End – 10.0%)
	2	R/W		Split end	Set set value end	1000	Split Start + 100 to 1000 (Split Start + 10.0% to 100.0%)
0xB6	1	R/W	Stroke limiter	Max pos	Stroke limiter valve position OPEN	1000	Min Pos to 1000 (Min Pos to 100.0%)
	2	R/W		Min pos	Stroke limiter valve position CLOSED	0	0 to Max Pos (0.0% to Max Pos)
0xB8	1	R/W	Set value (W) input	Direction	Set value direction set value input	0	0 → Rise (rising) 1 → Fall (falling)
	2	R/W		Type	Determine signal input	1	0 → 0 to 20 mA 1 → 4 to 20 mA 2 → 0 to 10 V
	3	R/W		I min	Determine minimum current input	35	0 to 40 (0 to 4.0 mA)
	4	R/W		I max	Determine maximum current input	205	200 to 220 (20.0 to 22.0 mA)
	5	R/W		U max	Determine maximum current input	103	100 to 110 (10.0 to 11.0 V)
0xBA	1	R/W	Analog output	Direction	Set value direction set value output	0	0 → Rise (rising) 1 → Fall (falling)
	2	R/W		Type	Determine signal output	1	0 → 0 to 20 mA 1 → 4 to 20 mA 2 → 0 to 10 V
	3	R/W		Min.	Determine minimum signal output	0	0 to Max (0.0% to Max)
	4	R/W		Max	Determine maximum signal output	1000	Min to 1000 (Min to 100%)

11.4 Parameter

The motorized linear actuator eSyStep supports parameter data in the ISDU (Index Service Data Unit). Parameters can be transmitted non-cyclically with ISDU. Block parametrization and data storage are also supported.

11.4.1 System command

The commands required for block parametrization and data storage are transmitted with the **System command** parameter.

Index	Sub-Index	Off-set	Access Rights	Length	Index name	Parameter	Type	Values
0x02	0	0	W	1 byte	System command		UIntegerT	0x01 to 0x06 0x82

Description of parameter values

Index name	Parameter	Values	Description
System command		0x01 to 0x06	Access to IO-Link
		0x82	Reset product to default settings *

* Except the index 0x90 settings – Drive Sets, these are not reset.

11.4.2 Data storage index

Changes to the parameters are stored in the IO-Link master with the **Data storage index** parameter and restored with a IO-Link device identical in construction when replaced. To do so, the **Data storage** parameter must be enabled in the Device access locks (see Chapter 11.4.3, page 30) parameter. The parameters are automatically replaced via the IO-Link master.

Index	Sub-Index	Off-set	Access Rights	Length	Index name	Parameter	Type	Values
0x03	1	0	R/W	1 byte	Data storage index	Data Storage Cmd	UIntegerT8	
	2	8	RO	1 byte		State Property	UIntegerT8	
	3	16	RO	4 bytes		Data Storage Size	UIntegerT32	
	4	48	RO	4 bytes		Parameter Check-sum	UIntegerT32	
	5	80	RO	41 bytes		Index List	OctetStringT	

11.4.3 Device access locks

Access to the parameters can be controlled with the **Device access locks** parameter.

Index	Sub-Index	Off-set	Access Rights	Length	Index name	Parameter	Type	Values
0x0C	1	0	R/W	1 bit	Device access locks	Parameter (write) access	BooleanT	0
								1
	2	1	R/W	1 bit		Data storage	BooleanT	0
								1
	3	2	R/W	1 bit		Local parameterization	BooleanT	0
								1
	4	3	R/W	1 bit		Local user interface	BooleanT	0
								1

Description of parameter values

Index name	Parameter	Values	Description
Device access locks	Local user interface	0	Enable write access
		1	Block write access
	Data storage	0	Enable storage of parameter data in the IO-Link master
		1	Block storage of parameter data in the IO-Link master
	Local parameterization	0	Enable local parameterization
		1	Block local parameterization
	Local user interface	0	Enable local user interface
		1	Block local user interface

11.4.4 Profile Characteristics

The **Profile Characteristics** parameter specifies which DeviceProfileIDs, CommonApplicationProfileIDs and FunctionClassIDs are supported.

Index	Sub-Index	Off-set	Access Rights	Length	Index name	Parameter	Type	Values
0x0D	0	0	RO	8 bytes	Profile Characteristics		ArrayT	0x8000
								0x8002
								0x8003
								0x8100

Description of parameter values

Index name	Parameter	Values	Description
Profile Characteristics		0x8000	Device identification objects
		0x8002	Process data mapping
		0x8003	Diagnostics
		0x8100	External identification

11.4.5 ProcessData Input Descriptor

The **ProcessData Input Descriptor** parameter describes the data format of the process data. Thus the master receives information about the process data without IODD.

Index	Sub-Index	Off-set	Access Rights	Length	Index name	Parameter	Type	Values
0x0E	0	0	RO	3 byte	ProcessData Input Descriptor		ArrayT	0x00
				0x03				
				0x01				

Description of parameter values

Index name	Parameter	Values	Description
ProcessData Input Descriptor		0x00	Bit offset
		0x03	Type length
		0x01	Data type -> BoolT

11.4.6 ProcessData Output Descriptor

The **ProcessData Output Descriptor** parameter describes the data format of the process data. Thus the master receives information about the process data without IODD.

Index	Sub-Index	Off-set	Access Rights	Length	Index name	Parameter	Type	Values
0x0F	0	0	RO	3 byte	ProcessData Output Descriptor		ArrayT	0x00
				0x04				
				0x01				

Description of parameter values

Index name	Parameter	Values	Description
ProcessData Output Descriptor		0x00	Bit offset
		0x04	Type length
		0x01	Data type -> BoolT

11.4.7 Vendor name

The manufacturer name can be read out in ASCII format with the **Vendor name** parameter.

Index	Sub-Index	Off-set	Access Rights	Length	Index name	Parameter	Type	Values
0x10	0	0	RO	5 bytes	Vendor name		StringT	"GEMUE"

11.4.8 Product name

The device name can be read out in ASCII format with the **Product name** parameter.

Index	Sub-Index	Off-set	Access Rights	Length	Index name	Parameter	Type	Values
0x12	0	0	RO	18 byte	Product name		StringT	"eSyStep Positioner"

11.4.9 Product ID

The product ID can be read out in ASCII format with the **Product ID** parameter.

Index	Sub-Index	Off-set	Access Rights	Length	Index name	Parameter	Type	Values
0x13	0	0	RO	18 byte	Product ID		StringT	"eSyStep Positioner"

11.4.10 Serial number

The serial number of the device can be read out with the **Serial number** parameter.

The serial number consists of an 8-digit traceability number, a forward slash and a 4-digit index.

Index	Sub-Index	Off-set	Access Rights	Length	Index name	Parameter	Type	Values
0x15	0	0	RO	13 bytes	Serial number		StringT	"XXXXXXXX/YYYY"

11.4.11 Hardware revision

The circuit boards' version can be read out with the **Hardware revision** parameter.

The hardware version is displayed with the 2-digit version number of the basic assembly and the 2-digit version number of the OPEN/CLOSED or positioner assembly.

Index	Sub-Index	Off-set	Access Rights	Length	Index name	Parameter	Type	Values
0x16	0	0	RO	10 bytes	Hardware revision		StringT	"Rev. XX/XX"

11.4.12 Firmware revision

The software version can be read out with the **Firmware revision** parameter.

Index	Sub-Index	Off-set	Access Rights	Length	Index name	Parameter	Type	Values
0x17	0	0	RO	21 byte	Firmware revision		StringT	"V X.X.X.X"

11.4.13 Application specific tag

A text with 32 characters can be stored in the device with the **Application specific tag** parameter.

For example, installation location, function, installation date, etc.

Index	Sub-Index	Off-set	Access Rights	Length	Index name	Parameter	Type	Values
0x18	0	0	R/W	32 bytes	Application specific tag		StringT	"***** "

11.4.14 Function tag

A text with 32 characters can be stored in the device with the **Function tag** parameter.

For example, installation location, function, installation date, etc.

Index	Sub-Index	Off-set	Access Rights	Length	Index name	Parameter	Type	Values
0x19	0	0	R/W	32 bytes	Function tag		StringT	„*****“

11.4.15 Location tag

A text with 32 characters can be stored in the device with the **Location tag** parameter.

For example, installation location, function, installation date, etc.

Index	Sub-Index	Off-set	Access Rights	Length	Index name	Parameter	Type	Values
0x1A	0	0	R/W	32 bytes	Location tag		StringT	„*****“

11.4.16 Device Status

The simple device status can be read out with the **Device Status** parameter.

Index	Sub-Index	Off-set	Access Rights	Length	Index name	Parameter	Type	Values
0x24	0	0	RO	1 byte	Device Status		uint: 8	0 2 4

Description of parameter values

Index name	Parameter	Values	Description
Device Status		0	The valve is operating properly
		2	The valve is operated outside the specification
		4	The valve is in fault status

11.4.17 Detailed Device Status

The detailed device status can be read out with the **Detailed Device Status** parameter. The values of the array correspond to the IO-Link events (see chapter 12.5 Events).

Index	Sub-Index	Off-set	Access Rights	Length	Index name	Parameter	Type	Values
0x25	0	0	RO	39 byte	Detailed Device Status		ArrayT	See chapter 12.5 Events

Description of parameter values

Index name	Parameter	Values	Description
Detailed Device Status			See chapter 12.5 Events

11.4.18 Actuator size

The actuator size can be read out in numbers with the **Actuator size** parameter.

Index	Sub-Index	Offset	Access Rights	Length	Index name	Parameter	Type	Default	Values
0x40	0	0	RO	2 bits	Actuator size		uint: 8	Depending on the actuator size used	0 → size 0 1 → size 1 2 → size 2

11.4.19 Function digital inputs

The functions of the digital inputs can be configured with the **Function digital inputs** parameter.

Index	Sub-Index	Offset	Access Rights	Length	Index name	Parameter	Type	Default	Values
0x4B	1	0	R/W	3 bits	Function digital inputs	Input 1	uint:8	4	0
									1
									2
									3
									4
	2	8	R/W	3 bits		Input 2	uint:8	0	0
									1
									2
									3
								4	

Description of parameter values

Index name	Parameter	Values	Description
Function digital inputs	Input 1	0	(Off) Input without function.
		1	(Open) In case of the corresponding signal, the actuator moves in the OPEN direction. If the other input (Digital Input 2) is configured as "Close", the actuator stops when the inputs are not actuated. If the other input is not configured as "Close", the actuator moves independently in the CLOSED direction when the "Open" input is not actuated.
		2	(Close) In case of the corresponding signal, the actuator moves in the CLOSED direction. If the other input (Digital Input 2) is configured as "Open", the actuator stops when the inputs are not actuated. If the other input is not configured as "Open", the actuator moves independently in the OPEN direction when the "Close" input is not actuated.
		3	(Safe / On) Safety position of the device is triggered. The device operates normally if the signal is active. If there is no signal, the device moves into the safety position. The safety position is defined by the parameter Error Action (index 0x4F (see "Error Action")).
		4	(Init) Input can be used as an initialization input.
	Input 2	0	(Off) Input without function.
		1	(Open) In case of the corresponding signal, the actuator moves in the OPEN direction. If the other input (Digital Input 1) is configured as "Close", the actuator stops when the inputs are not actuated. If the other input is not configured as "Close", the actuator moves independently in the CLOSED direction when the "Open" input is not actuated.
		2	(Close) In case of the corresponding signal, the actuator moves in the CLOSED direction. If the other input (Digital Input 1) is configured as "Open", the actuator stops when the inputs are not actuated. If the other input is not configured as "Open", the actuator moves independently in the OPEN direction when the "Close" input is not actuated.
		3	(Safe/On) Safety position of the device is triggered. The device operates normally if the signal is active. If there is no signal, the device moves into the safety position. The safety position is defined by the parameter Error Action (index 0x4F (see "Error Action")).
		4	(Init) Input can be used as an initialization input.

11.4.20 Function digital in- / output 1

The function of the input/output can be set with the **Function Digital In-/Output 1** (subindex 1) parameter.

Index	Sub-Index	Offset	Access Rights	Length	Index name	Parameter	Type	Default	Values
0x4C	1	0	R/W	3 bits	Function digital in- / output 1	In- / output 1	uint:8	2	0
									1
									2
									3
									4
	2	8	R/W	3 bits		Type in- / output 1	uint:8	0	0
	1								
	2								

Description of parameter values

Index name	Parameter	Values	Description
Function digital in- / output 1	In- / output	0	(Output Open) Signal is output with the corresponding valve position. Detection of Open depends on the setting of the parameter Position Feedback (index 0x51 (see "Actuator position feedback", page 40)) and a correct initialization.
		1	(Output Close) Signal is output with the corresponding valve position. Detection of Close depends on the setting of the parameter Position Feedback (index 0x51 (see "Actuator position feedback", page 40)) and a correct initialization.
		2	(Output Error) Only output error detection.
		3	(Output Error & Warning) Output error and warnings.
		4	(Input Init) Configure input/output as initialization input.
	Type in- / output	0	(Push-Pull) Configure output as Push-Pull.
		1	(NPN) Configure output as NPN.
		2	(PNP) Configure output as PNP.

11.4.21 Function digital output 2

The output function can be set with the **Function digital output 2** parameter.

Index	Sub-Index	Offset	Access Rights	Length	Index name	Parameter	Type	Default	Values	
0x4D	0	0	R/W	2 bits	Function digital output 2		uint:8	2	0	
										1
										2
										3

Description of parameter values

Index name	Parameter	Values	Description
Function digital output		0	(Output Open) Signal is output with the corresponding valve position. Detection of Open depends on the setting of the parameter Position Feedback (index 0x51 (see "Actuator position feedback", page 40)) and a correct initialization.
		1	(Output Close) Signal is output with the corresponding valve position. Detection of Close depends on the setting of the parameter Position Feedback (index 0x51 (see "Actuator position feedback", page 40)) and a correct initialization.
		2	(Output Error) Only output error detection.
		3	(Output Error & Warning) Output error and warnings.

11.4.22 Logic digital inputs / outputs

The inputs and outputs can be inverted with the **Logic digital inputs/outputs** parameters.

Index	Sub-Index	Offset	Access Rights	Length	Index name	Parameter	Type	Default	Values
0x4E	1	0	R/W	1 bit	Logic digital inputs / outputs	Input 1	Boolean	0	0
									1
	2	1	R/W	1 bit		Input 2	Boolean	0	0
									1
	3	2	R/W	1 bit		Input / output 1	Boolean	0	0
									1
	4	3	R/W	1 bit		Output 2	Boolean	0	0
									1

Description of parameter values

Index name	Parameter	Values	Description
Logic digital inputs / outputs	Input 1	0	(Active high) Input 1 not inverted.
		1	(Active low) Input 1 inverted.
	Input 2	0	(Active high) Input 2 not inverted.
		1	(Active low) Input 2 inverted.
	Input / output 1	0	(Active high) Input/output not inverted.
		1	(Active low) Input/output inverted.
	Output 2	0	(Active high) Output not inverted.
		1	(Active low) Output inverted.

11.4.23 Error action

The safety position can be set with the **Error action** parameter.

The safety position is approached when an error occurs, if the supply voltage is too low within the range of 17.8 V to 21.1 V or in case of the corresponding signal present at Safe/On.

NOTICE

► Except the Temperature Over-Run error device, exceeding the permissible motor temperature. If the permissible temperature is exceeded, the motor is switched off to prevent damage.

Index	Sub-Index	Off-set	Access Rights	Length	Index name	Parameter	Type	Default	Values
0x4F	1	0	R/W	2 bits	Error action	Error action	uint:8	2	0
	2	0	R/W	10 bits		Error time	uint:16	1 (0.1s)	2
									1 ... 1000 (0.1s to 100s)

Description of parameter values

Index name	Parameter	Values	Description
Error action	Error action	0	(Hold) Actuator remains in the current position in case of an error.
		1	(Open) Actuator moves to the OPEN position in case of an error.
		2	(Close) Actuator moves to the CLOSED position in case of an error.
	Error time	1 ... 1000	Determine delay time between error detection and error message.

11.4.24 Basic settings

The different settings are summarized with the **Basic settings** parameter.

Index	Sub-Index	Offset	Access Rights	Length	Index name	Parameter	Type	Default	Values
0x50	1	0	R/W	1 bit	Basic settings	Inversion of LED colours	Boolean	0	0
									1
	2	1	R/W	1 bit		On site initialization	Boolean	0	0
									1
	3	2	R/W	1 bit		Operating mode	Boolean	0	0
									1
	4	3	R/W	1 bit		IO-Link process data	Boolean	0	0
									1

Description of parameter values

Index name	Parameter	Values	Description
Basic settings	Inversion of LED colours	0	(Standard) LEDs Close = green and Open = yellow (not inverted).
		1	(Inversed) LEDs Close = yellow and Open = green (inversed).
	On site initialization	0	(Enabled) On-site initialization activated.
		1	(Disabled) On-site initialization deactivated.
	Operating mode	0	Operating mode for positioner activated.
		1	Operating mode for OPEN/CLOSE control activated.
	IO-Link process data	0	(Disabled) Use of IO-Link process data (see "Process data", page 24) is deactivated.
		1	(Enabled) Use of IO-Link process data (see "Process data", page 24) is activated.

11.4.25 Actuator position feedback

The settings for the OPEN and CLOSED position feedback can be stored with the **Actuator position feedback** parameter.

Index	Sub-Index	Offset	Access Rights	Length	Index name	Parameter	Type	Default	Values
0x51	1	0	R/W	10 bits	Actuator position feedback	Open request	uint:16	900 (90.0%)	30 ... 970 (3.0 ... 97.0%)
	2	16	R/W	10 bits		Close request	uint:16	100 (10.0%)	30 ... 970 (3.0 ... 97.0%)
	3	32	RO	10 bits		Open real	uint:16		0 ... 4095
	4	48	RO	10 bits		Close real	uint:16		0 ... 4095

Description of parameter values

Index name	Parameter	Values	Description
Actuator position feedback	Open request	30 ... 970 (3.0 ... 97.0%)	Request valve position OPEN
	Close request	30 ... 970 (3.0 ... 97.0%)	Request valve position CLOSED
	Open real	0 ... 4095	Real valve position OPEN
	Close real	0 ... 4095	Real valve position CLOSED

11.4.26 Initialized positions

The analog values of the initialized valve positions can be read out with the **Initialized positions** parameter.

Index	Sub-Index	Offset	Access Rights	Length	Index name	Parameter	Type	Default	Values
0x53	1	0	RO	12 bits	Initialized positions	Open	uint:16	0	0 ... 4092
	2	16	RO	12 bits		Close	uint:16	4092	0 ... 4092
	3	32	RO	12 bits		Stroke	uint:16	0	0 ... 4092

Description of parameter values

Index name	Parameter	Values	Description
Initialized positions	Open	0 ... 4092	Analog value valve position OPEN
	Close	0 ... 4092	Analog value valve position CLOSED
	Stroke	0 ... 4092	Analog value stroke (difference between OPEN and CLOSED).

11.4.27 Calibration positions

The values of the factory calibration can be read out with the **Calibration positions** parameter.

The values are analog values of the potentiometer in the mechanical end positions of the actuator.

Index	Sub-Index	Off-set	Access Rights	Length	Index name	Parameter	Type	Default	Values
0x55	1	0	RO	12 bits	Calibration positions	Max.	uint:16	0	0 ... 4092
	2	16	RO	12 bits		Min.	uint:16	4092	0 ... 4092

Description of parameter values

Index name	Parameter	Values	Description
Calibration positions	Max.	0 ... 4092	Read out analog value of the potentiometer for the mechanical end position OPEN.
	Min.	0 ... 4092	Read out analog value of the potentiometer for the mechanical end position CLOSED.

11.4.28 Analog values

Different analog values can be read out with the **Analog values** parameter.

Index	Sub-Index	Off-set	Access Rights	Length	Index name	Parameter	Type	Values
0x60	1	0	RO	12 bits	Analog values	Potentiometer	uint:16	0 ... 4095
	2	16	RO	12 bits		Supply voltage	uint:16	0 ... 4095
	3	32	RO	12 bits		Temperature	uint:16	0 ... 4095
	4	48	RO	12 bits		Set value (W)	uint:16	0 ... 4095

Description of parameter values

Index name	Parameter	Values	Description
Analog values	Potentiometer	0 ... 4095	Read out current analog value of the potentiometer.
	Supply voltage	0 ... 4095	Read out current analog value of the supply voltage.
	Temperature	0 ... 4095	Read out current analog value of the temperature sensor.
	Set value (W)	0 ... 4095	Read out current analog value of the set value.

11.4.29 Operating times

The current valve travel times can be read out with the **Operating times** parameter.

Index	Sub-Index	Offset	Access Rights	Length	Index name	Parameter	Type	Default	Values
0x62	1	0	RO	8 bits	Operating times	Open	uint:8	0	0 to 255, 0 to 25.5 s
	2	8	RO	8 bits		Close	uint:8	0	0 to 255, 0 to 25.5 s

Description of parameter values

Index name	Parameter	Values	Description
Operating times	Open	0 to 255 0 to 25.5 s	Read out operating time (in tenths of seconds) from end position CLOSED to end position OPEN.
	Close	0 to 255 0 to 25.5 s	Read out operating time (in tenths of seconds) from end position OPEN to end position CLOSED.

11.4.30 Drive sets

The force of the actuator can be influenced with the **Drive sets** parameter when the valve is initialized and during initialization.

Index	Sub-Index	Offset	Access Rights	Length	Index name	Parameter	Type	Default	Values
0x90	2	8	R/W	3 bits	Drive sets	Force	uint:16	-	1 ... 6
	3	16	R/W	3 bits		Force initialization	uint:16	-	1 ... 6

Description of parameter values

Index name	Parameter	Values	Description
Drive sets	Force	1 ... 6	Set the force of the valve. Preset at the factory depending on the valve type.
	Force initialization	1 ... 6	Set the force during initialization. Preset at the factory depending on the valve type.

Force settings

Actuator size	Setting parameter	Force
AG0 and AG1	1	Minimum force
	6	Maximum force

11.4.31 Control parameters

The properties can be set with the **Control parameters** parameter.

Index	Sub-Index	Offset	Access Rights	Length	Index name	Parameter	Type	Default	Values
0xB0	1	0	R/W	16 bits	Control parameters	P amplification	uint: 16	200	1 ... 200 (0.1 ... 20.0)
	2	16	R/W	16 bits		D amplification	uint: 16	10	1 ... 200 (0.1 ... 20.0)
	3	32	R/W	16 bits		Derivative time	uint: 16	0	0 to 100 (0 to 100 s)
	4	48	R/W	16 bits		Dead band	uint: 16	10	1 ... 250 (0.1 ... 25.0 %)

Description of parameter values

Index name	Parameter	Values	Description
Control parameters	P amplification	1 ... 200 (0.1 ... 20.0)	Set the P component of the positioner.
	D amplification	1 ... 200 (0.1 ... 20.0)	Set the D component of the positioner.
	Derivative time	0 to 100 (0 to 100 s)	Set the delay constant of the positioner.
	Dead band	1 ... 250 (0.1 ... 25.0 %)	Set the permissible system deviation of the positioner.

11.4.32 Open / close tight

The sealing function can be set for the **Open / close tight** parameter.

Index	Sub-Index	Offset	Access Rights	Length	Index name	Parameter	Type	Default	Values
0xB2	1	0	R/W	16 bits	Open / close tight	Open tight	uint:16	995	800 ... 1000 (80.0 ... 100.0 %)
	2	16	R/W	16 bits		Close tight	uint:16	5	0 ... 200 (0.0 ... 20.0 %)

Description of parameter values

Index name	Parameter	Values	Description
Open / close tight	Open tight	800 ... 1000 (80.0 ... 100.0 %)	Set the sealing function valve position OPEN.
	Close tight	0 ... 200 (0 ... 20.0 %)	Set the sealing function valve position CLOSED.

11.4.33 Split range

The start and end of the set value range can be set for **Split range** parameter.

Index	Sub-Index	Offset	Access Rights	Length	Index name	Parameter	Type	Default	Values
0xB4	1	0	R/W	16 bits	Split range	Split start	uint: 16	0	0 to Split End – 100 (0.0 to Split End – 10.0%)
	2	16	R/W	16 bits		Split end	uint: 16	1000	Split Start + 100 to 1000 (Split Start + 10.0% to 100.0%)

Description of parameter values

Index name	Parameter	Values	Description
Split range	Split start	0 to Split End – 100 (0.0 to Split End – 10.0%)	Set the start of the set value range.
	Split end	Split Start + 100 to 1000 (Split Start + 10.0% to 100.0%)	Set the end of the set value range.

11.4.34 Stroke limiter

The upper and lower valve position of the control range can be set as stroke limiter with the **Stroke limiter** parameter.

NOTICE

To use the stroke limiter, the close tight function (open/close tight) must be deactivated. To do this, Open tight must be set to the value 1000 (100.0%) and Close tight to the value 0 (0.0%).

Index	Sub-Index	Offset	Access Rights	Length	Index name	Parameter	Type	Default	Values
0xB6	1	0	R/W	16 bits	Stroke limiter	Max pos	uint:16	1000	Min Pos to 1000 (Min Pos to 100.0%)
	2	16	R/W	16 bits		Min pos	uint:16	0	0 to Max Pos (0.0% to Max Pos)

Description of parameter values

Index name	Parameter	Values	Description
Stroke limiter	Max pos	Min Pos to 1000 (Min Pos to 100.0%)	Set the stroke limiter of the control range in valve position OPEN.
	Min pos	0 to Max Pos (0.0% to Max Pos)	Set the stroke limiter of the control range in valve position CLOSED.

11.4.35 Set value (W) input

The function of the analog input can be set with the **Set value (W) input** parameter.

Index	Sub-Index	Offset	Access Rights	Length	Index name	Parameter	Type	Default	Values
0xB8	1	0	R/W	1 bit	Set value (W) input	Direction	uint:1	0	0 1
	2	8	R/W	2 bits		Type	uint:2	1	0 1 2
	3	16	R/W	8 bits		I min	uint:8	35	0 to 40 (0 to 4.0 mA)
	4	24	R/W	8 bits		I max	uint:8	205	200 to 220 (20.0 to 22.0 mA)
	5	32	R/W	8 bits		U max	uint:8	103	100 to 110 (10.0 to 11.0 V)

Description of parameter values

Index name	Parameter	Values	Description
Set value (W) input	Direction	0 1	Specify direction of the set value input. 0 = Rise (rising) 1 = Fall (falling)
	Type	0 1 2	Determine signal input. 0 = 0 to 20 mA 1 = 4 to 20 mA 2 = 0 to 10 V
	I min	0 to 40 (0 to 4.0 mA)	Determine minimum value of the current input. If the set value is not reached, the message "Set value too small" is issued.
	I max	200 to 220 (20.0 to 22.0 mA)	Determine maximum value of the current input. If the set value is exceeded, the message "Set value too high" is issued.
	U max	100 to 110 (10.0 to 11.0 V)	Determine maximum value of the voltage input. If the set value is exceeded, the message "Set value too high" is issued.

11.4.36 Analog output

The analog output function can be set with the **Analog Output** parameter.

Index	Sub-Index	Offset	Access Rights	Length	Index name	Parameter	Type	Default	Values
0xBA	1	0	R/W	1 bit	Analog output	Direction	Boolean	0	0 1
	2	8	R/W	2 bits		Type	uint:8	1	0 1 2
	3	16	R/W	16 bits		Min.	uint:16	0	0 to Max (0.0% to Max)
	4	32	R/W	16 bits		Max.	uint:16	1000	Min to 1000 (Min to 100%)

Description of parameter values

Index name	Parameter	Values	Description
Analog output	Direction	0	Specify direction of the set value output. 0 = Rise (rising) 1 = Fall (falling)
		1	
	Type	0	Determine signal output. 0 = 0 to 20 mA 1 = 4 to 20 mA 2 = 0 to 10 V
		1	
2			
Min.	0 to Max (0.0% to Max)	Determine minimum value of the output.	
Max.	Min to 1000 (Min to 100%)	Determine maximum value of the output.	

11.5 Events

The following IO-Link events can be transmitted.

Event	Mode	Type	Code
Device Hardware Fault	App/Disapp	Error	0x5000
Motor Unable To Move	App/Disapp	Error	0x8CE0
Device Temperature Over-Run	App/Disapp	Warning/Error	0x4210
Emergency Power	App/Disapp	Warning	0x5100
Primary Supply Voltage Under-Run	App/Disapp	Error	0x5111
Potifail Close	App/Disapp	Warning	0x8CA5
Potifail Open	App/Disapp	Warning	0x8CA4

Description – Events

Event	Description	Possible cause	Troubleshooting
Device Hardware Fault 0x5000	The event occurs when a hardware fault is detected.	Fault in valve position detection.	Contact GEMÜ Support
		Parameter can no longer be read when switching the device on.	
Motor Unable To Move 0x8CE0	The event occurs when the motor is blocked.	Valve is blocked (for example, solid stuck in valve).	Check valve Carry out initialization if valve is OK
		Valve corroded (rusted in place).	

Event	Description	Possible cause	Troubleshooting
		End position can no longer be reached (after replacing the diaphragm).	
Device Temperature Over-Run 0x4210	The event occurs as a warning or error if the motor temperature is too high.	Control is operated outside of the specification. The ambient temperature is too high.	Check temperature Set control correctly (check duty cycle (ED) of the actuator)
Emergency Power 0x5100	The event occurs if the supply is too low. The event is triggered as a warning if the supply voltage U_v is below a value of 21.1 V. (If the supply voltage is below 17.4 V, the event Primary Supply Voltage Under-Run (0x5111) is triggered as an error).	Power supply unit overloaded. Cross-section of the supply line is too small. Supply line is too long.	Check supply
Primary Supply Voltage Under-Run 0x5111	The event occurs if the supply voltage is too low.	Power supply unit overloaded. Cross-section of the supply line is too small. Supply line is too long.	Check supply
Potifail Close 0x8CA5	The event occurs if a valve position is read which can never be achieved in the "Close" direction.	Fault in valve position detection. Error when replacing a diaphragm (stroke of the valve in incorrect area). Actuator has been fitted on the valve incorrectly (stroke of the valve in the incorrect area).	Check valve/diaphragm
Potifail Open 0x8CA4	The event occurs if a valve position is read which can never be achieved in the "Open" direction.	Fault in valve position detection. Error when replacing a diaphragm (stroke of the valve in incorrect area). Actuator has been fitted on the valve incorrectly (stroke of the valve in the incorrect area).	Check valve/diaphragm

12 Operation

12.1 Initialization

NOTICE

- Initialization should be carried out in a depressurized condition (initialization force = 1/2 nominal force). For initialization under operating pressure, the initialization force (IO-Link index 0x90 – subindex 3 – Force initialization) must be adapted.

Initialization must be carried out in the following situations:

- Retrofitting an electrical position indicator
- Tube replacement
- Tube holder replacement
- Compressor replacement

If the process valve is fully assembled at the factory, initialization has already been carried out.

Initialization can be carried out using the following procedures:

- On-site initialization
- Initialization via IO-Link
- Initialization via configurable digital input (digital input must be set to "Init")

12.1.1 On-site initialization of the end positions

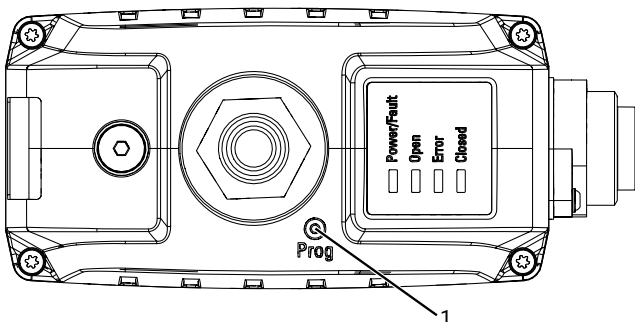

1. Connect supply voltage.
2. Hold the magnet briefly (>100 ms) at the point on the housing cover marked with PROG 1.
 - ⇒ OPEN and CLOSED LEDs flash alternately.
3. Valve automatically moves into the OPEN position.
4. Valve automatically moves into the CLOSED position.
5. Initialization mode is automatically ended.
6. The end positions are set.

12.1.2 Initialization of the end positions via IO-Link

1. Briefly activate (>100 ms) initialization mode (process data "Selection of operating mode").
 - ⇒ OPEN and CLOSED LEDs flash alternately.
2. Valve automatically moves into the OPEN position.
3. Valve automatically moves into the CLOSED position.
4. Initialization mode is automatically ended.
5. The end positions are set.

12.2 Manual override

Open, actuate and close the manual override with the hexagon socket (SW3).

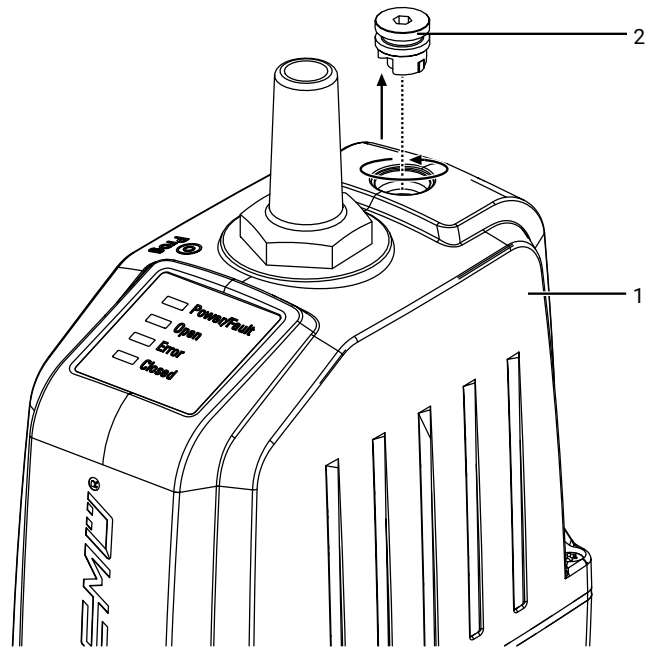

1. Unscrew sealing plug 2 anti-clockwise out of cover 1 and remove it.

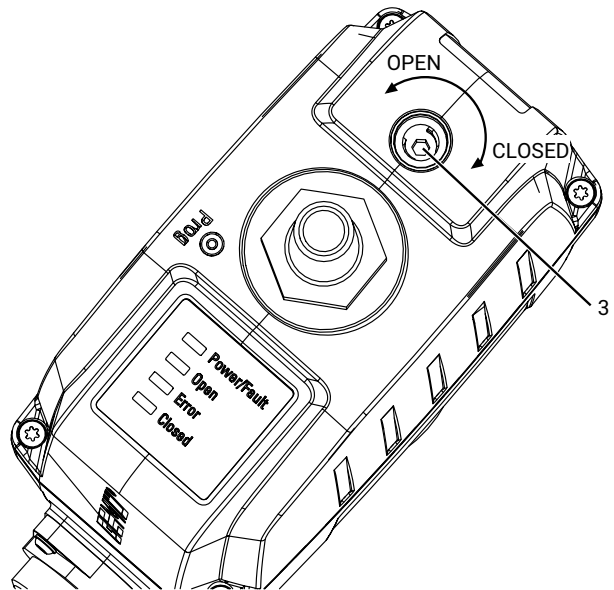

2. Operate the manual override 3 with the hexagon socket (WAF3).
 - ⇒ Turn clockwise to close the valve.
 - ⇒ Turn anticlockwise to open the valve.

13 Inspection and maintenance

⚠ WARNING

The equipment is subject to pressure!

- ▶ Risk of severe injury or death
- Depressurize the plant.
- Completely drain the plant.

⚠ CAUTION

Use of incorrect spare parts!

- ▶ Damage to the GEMÜ product
- ▶ Manufacturer liability and guarantee will be void
- Use only genuine parts from GEMÜ.

⚠ CAUTION



Hot plant components!

- ▶ Risk of burns
- Only work on plant that has cooled down.

⚠ CAUTION



Risk of crushing!

- ▶ Risk of severe injury!
- Before performing any work on the GEMÜ product, depressurize the plant.

NOTICE

Requirements for tube lines used!

- ▶ Use tube lines suitable for the application, see manufacturer's information.
- Only use undamaged tube lines.

NOTICE

Lay tube lines professionally!

- ▶ Lay tube lines professionally and do not bend them below the minimum bending radius, see manufacturer's information.
- Do not kink or twist the tube lines.

NOTICE

Exceptional maintenance work!

- ▶ Damage to the GEMÜ product
- Any maintenance work and repairs not described in these operating instructions must not be performed without consulting the manufacturer first.

The operator must carry out regular visual examination of the GEMÜ products dependent on the operating conditions and the potential danger in order to prevent leakage and damage.

The product also must be disassembled and checked for wear in the corresponding intervals.

1. Have servicing and maintenance work performed by trained personnel.
2. Wear appropriate protective gear as specified in plant operator's guidelines.
3. Shut off plant or plant component.
4. Secure the plant or plant component against recommissioning.
5. Depressurize the plant or plant component.
6. Actuate GEMÜ products which are always in the same position four times a year.
7. If necessary, the end position counter **User** can be reset after maintenance or other changes under parameter Cycle Counter.

13.1 Removing the tube

⚠ CAUTION



Risk of crushing!

- ▶ While the tube holder is open, the actuator can move. Severe injury due to crushing or shearing of the fingers.
- Ensure that the actuator remains in the open position during tube replacement.
- Do not reach into the tube crushing area.

1. Move the actuator **A** to the open position.

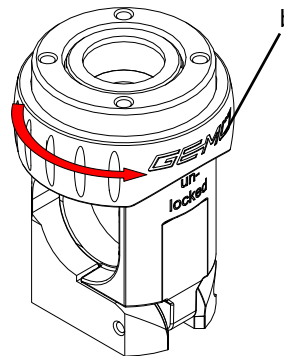

2. Turn the locking ring **b** by 90° in the direction of the arrow.
 - ⇒ The word "unlocked" can be read on the tube holder.

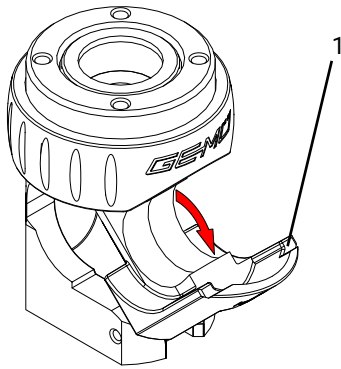

3. Open the tube holder 1.
4. Remove the tube.

13.2 Disassembling the tube holder

1. Remove the tube (see "Removing the tube", page 49).

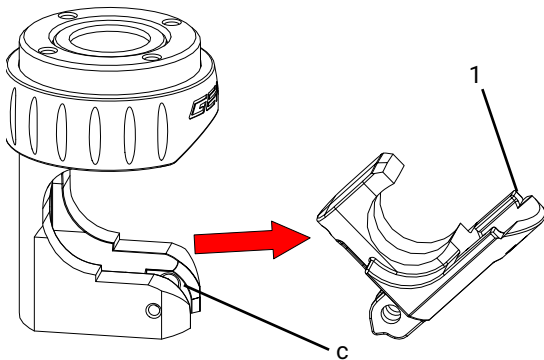

2. Loosen the fixing screw c using an Allen key.
3. Remove the tube holder 1.

13.3 Disassembling the compressor

⚠ CAUTION	
	<p>Risk of crushing due to the compressor shutting down!</p> <ul style="list-style-type: none"> ▶ Severe injury due to crushing or shearing of the fingers. ● Ensure that the actuator remains in the open position while replacing the compressor. ● Do not reach into the tube crushing area.

1. Remove the tube (see "Removing the tube", page 49).
2. Disassemble the tube holder (see "Disassembling the tube holder", page 50).
3. Move the actuator A to the closed position.

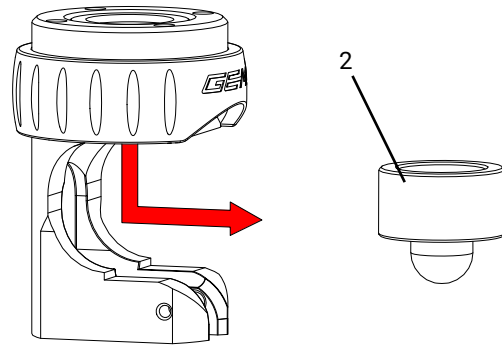

4. Pull the compressor 2 out downwards.

13.4 Installing the compressor

⚠ CAUTION	
	<p>Risk of crushing due to the compressor shutting down!</p> <ul style="list-style-type: none"> ▶ Severe injury due to crushing or shearing of the fingers. ● Ensure that the actuator remains in the open position while replacing the compressor. ● Do not reach into the tube crushing area.

1. Remove the tube (see "Removing the tube", page 49).
2. Disassemble the tube holder (see "Disassembling the tube holder", page 50).
3. Disassemble the compressor (see "Disassembling the compressor", page 50).

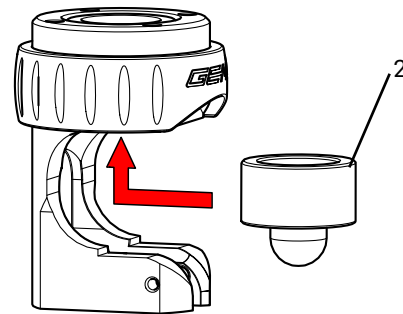

4. Insert the compressor 2 and press upwards until the compressor engages.
5. Move the actuator A to the open position.

13.5 Assembling the tube holder

1. Disassemble the tube holder (see "Disassembling the tube holder", page 50).

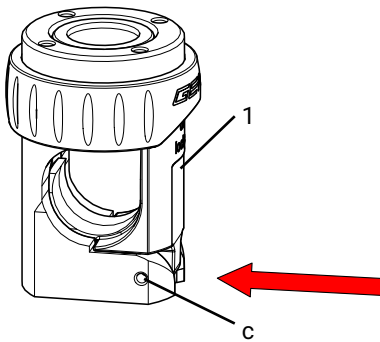

2. Insert the tube holder 1.
3. Tighten the fixing screw **c** using an Allen key.

13.6 Inserting the tube

1. Remove the tube (see "Removing the tube", page 49).
2. Insert the tube.

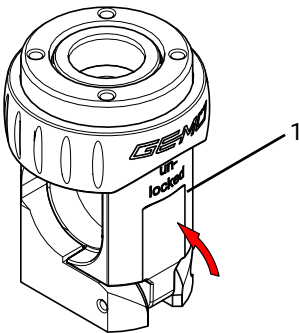

3. Close the tube holder 1.

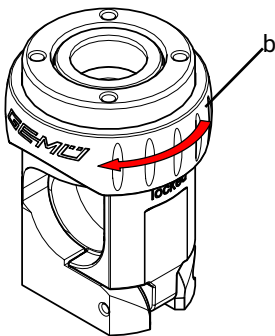

4. Turn the locking ring **b** by 90° in the direction of the arrow.
⇒ The word "locked" can be read on the tube holder.
5. With the valve fully assembled, check the function and tightness.

14 Troubleshooting

14.1 LED error message

Function	Power/fault	Open	Error	Closed
Supply voltage too low				
	red			
Software Update				
Internal error				
Product not calibrated				
Motor does not move				
Product not initialized				
		Open and Closed flash alternately		
Temperature error				
Emergency power operation, OPEN position				
	red			
Emergency power operation, CLOSED position				
	red			
Emergency power operation, position unknown				
	red			
Set value too small				
Set value too high				
Abort IO-Link communication				
Maintenance required, OPEN position				
Maintenance required, CLOSED position				
Maintenance required, position unknown				

14.2 Troubleshooting

Error	Possible cause	Troubleshooting
The product is leaking downstream (does not close or does not close fully)	Operating pressure too high	Operate the product with operating pressure specified in datasheet
	Tube leaking or damaged	Check tube for potential damage, replace tube if necessary
The product does not open or does not open fully	Actuator defective	Replace valve
	Foreign matter in the product	Remove and clean the product
	The actuator design is not suitable for the operating conditions	Use an actuator that is designed for the operating conditions
	Voltage is not connected	Connect voltage
	Cable ends incorrectly wired	Wire cable ends correctly
The product does not close or does not close fully	The actuator design is not suitable for the operating conditions	Use an actuator that is designed for the operating conditions
	Foreign matter in the product	Remove and clean the product
	Voltage is not connected	Connect voltage

15 Removal

1. Remove in reverse order to installation.
2. Unscrew the electrical wiring.
3. Disassemble the product. Observe warning notes and safety information.

16 Disposal

1. Pay attention to adhered residual material and gas diffusion from penetrated media.
2. Dispose of all parts in accordance with the disposal regulations/environmental protection laws.

17 Returns

Legal regulations for the protection of the environment and personnel require that the completed and signed return delivery note is included with the dispatch documents. Returned goods can be processed only when this note is completed. If no return delivery note is included with the product, GEMÜ cannot process credits or repair work but will dispose of the goods at the operator's expense.

1. Clean the product.
2. Request a return delivery note from GEMÜ.
3. Complete the return delivery note.
4. Send the product with a completed return delivery note to GEMÜ.



GEMÜ Gebr. Müller Apparatebau GmbH & Co. KG
Fritz-Müller-Straße 6-8, 74653 Ingelfingen-Criesbach, Germany
Phone +49 (0) 7940 1230 · info@gemue.de
www.gemu-group.com

Subject to alteration

03.2023 | 88723858