

GEMÜ R91

Metal dual plate check valve

EN

Operating instructions



All rights including copyrights or industrial property rights are expressly reserved.

Keep the document for future reference.

© GEMÜ Gebr. Müller Apparatebau GmbH & Co. KG
07.08.2023

Contents

1	General information	4
1.1	Information	4
1.2	Symbols used	4
1.3	Definition of terms	4
1.4	Warning notes	4
2	Safety information	5
3.1	Construction	5
3.2	Description	5
3.3	Function	5
3.4	Product label	6
4	Correct use	6
5	Order data	7
5.1	Order codes	7
5.2	Order example	7
6	Technical data	8
6.1	Medium	8
6.2	Temperature	8
6.3	Pressure	8
6.4	Product conformities	9
6.5	Mechanical data	10
7	Dimensions	11
8	Manufacturer's information	12
8.1	Delivery	12
8.2	Packaging	12
8.3	Transport	12
8.4	Storage	12
9	Installation in piping	12
9.1	Preparing for installation	12
9.2	Installation	13
10	Commissioning	14
11	Troubleshooting	15
12	Inspection and maintenance	16
12.1	Spare parts	16
13	Removal from piping	16
14	Disposal	16
15	Returns	17
16	Declaration of Incorporation according to 2006/42/EC (Machinery Directive)	18
17	Declaration of conformity according to 2014/68/ EU (Pressure Equipment Directive)	19

1 General information

1.1 Information

- The descriptions and instructions apply to the standard versions. For special versions not described in this document the basic information contained herein applies in combination with any additional special documentation.
- Correct installation, operation, maintenance and repair work ensure faultless operation of the product.
- Should there be any doubts or misunderstandings, the German version is the authoritative document.
- Contact us at the address on the last page for staff training information.

1.2 Symbols used

The following symbols are used in this document:

Symbol	Meaning
●	Tasks to be performed
▶	Response(s) to tasks
–	Lists

1.3 Definition of terms

Working medium

The medium that flows through the GEMÜ product.

1.4 Warning notes



Wherever possible, warning notes are organised according to the following scheme:

SIGNAL WORD	
Possible symbol for the specific danger	<p>Type and source of the danger</p> <ul style="list-style-type: none"> ▶ Possible consequences of non-observance. ● Measures for avoiding danger.

Warning notes are always marked with a signal word and sometimes also with a symbol for the specific danger.





The following signal words and danger levels are used:

 DANGER	
	<p>Imminent danger!</p> <ul style="list-style-type: none"> ▶ Non-observance can cause death or severe injury.
 WARNING	
	<p>Potentially dangerous situation!</p> <ul style="list-style-type: none"> ▶ Non-observance can cause death or severe injury.

 CAUTION	
	<p>Potentially dangerous situation!</p> <ul style="list-style-type: none"> ▶ Non-observance can cause moderate to light injury.

NOTICE	
	<p>Potentially dangerous situation!</p> <ul style="list-style-type: none"> ▶ Non-observance can cause damage to property.

The following symbols for the specific dangers can be used within a warning note:

Symbol	Meaning
	Danger of explosion!
	Risk of crushing!
	Corrosive chemicals!
	Hot plant components!
	Replacement of spare parts

2 Safety information

The safety information in this document refers only to an individual product. Potentially dangerous conditions can arise in combination with other plant components, which need to be considered on the basis of a risk analysis. The operator is responsible for the production of the risk analysis and for compliance with the resulting precautionary measures and regional safety regulations.

The document contains fundamental safety information that must be observed during commissioning, operation and maintenance. Non-compliance with these instructions may cause:

- Personal hazard due to electrical, mechanical and chemical effects.
- Hazard to nearby equipment.
- Failure of important functions.
- Hazard to the environment due to the leakage of dangerous substances.

The safety information does not take into account:

- Unexpected incidents and events, which may occur during installation, operation and maintenance.
- Local safety regulations which must be adhered to by the operator and by any additional installation personnel.

Prior to commissioning:

1. Transport and store the product correctly.
2. Do not paint the bolts and plastic parts of the product.
3. Carry out installation and commissioning using trained personnel.
4. Provide adequate training for installation and operating personnel.
5. Ensure that the contents of the document have been fully understood by the responsible personnel.
6. Define the areas of responsibility.
7. Observe the safety data sheets.
8. Observe the safety regulations for the media used.

During operation:

9. Keep this document available at the place of use.
10. Observe the safety information.
11. Operate the product in accordance with this document.
12. Operate the product in accordance with the specifications.
13. Maintain the product correctly.
14. Do not carry out any maintenance work and repairs not described in this document without consulting the manufacturer first.

In cases of uncertainty:

15. Consult the nearest GEMÜ sales office.

3 Product description

3.1 Construction

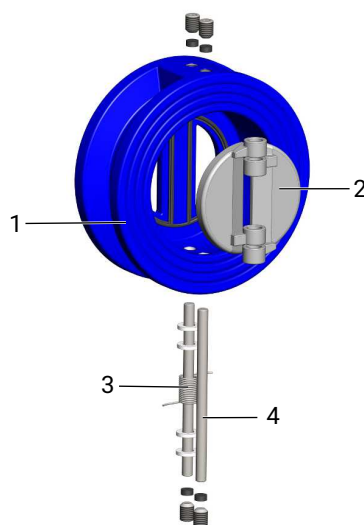

Item	Name	Materials
1	Body	1.0619, galvanized cast steel material, 1.4408, investment casting material, EN-GJS-400-15, SG iron material
2	Dual plates	1.4408, investment casting material, 1.4469, duplex cast steel material, EN-GJS-400-15, SG iron material
3	Spring	1.4571, spring steel
4	Shaft	1.4401
	Seal materials	EPDM, FKM, NBR

3.2 Description

The GEMÜ R91 is a metal dual plate check valve with flange connection and standardized length to DIN EN 558-1. The valve body, plates and seals are available in various materials. In the version with metallic seal, the GEMÜ R91 valve can be used at high temperatures up to 300 °C.

3.3 Function

The flow of fluid causes disc 2 in the check valve to open. Check valves need a low opening pressure. The resulting opening force moves the disc 2 against the spring 3 by overcoming the the weight force of the disc 2 and the spring force of the spring 3 so that the medium is released.

3.4 Product label

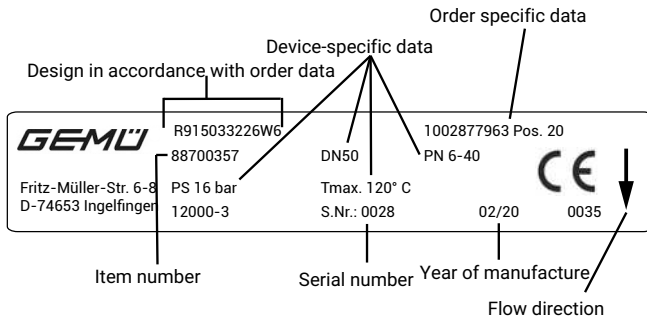

4 Correct use

⚠ DANGER	
	<p>Danger of explosion!</p> <ul style="list-style-type: none"> ▶ Risk of death or severe injury ● Do not use the product in potentially explosive zones.
⚠ WARNING	
<p>Improper use of the product!</p> <ul style="list-style-type: none"> ▶ Risk of severe injury or death ▶ Manufacturer liability and guarantee will be void ● Only use the product in accordance with the operating conditions specified in the contract documentation and in this document. 	

The product is designed for installation in piping systems and for controlling a working medium.

The product is not intended for use in potentially explosive areas.

5 Order data

The order data provide an overview of standard configurations.

Please check the availability before ordering. Other configurations available on request.

Order codes

1 Type	Code
Dual plate check valve, metal	R91

2 DN	Code
DN 50	50
DN 65	65
DN 80	80
DN 100	100
DN 125	125
DN 150	150
DN 200	200
DN 250	250
DN 300	300
DN 350	350
DN 400	400
DN 450	450
DN 500	500
DN 600	600

3 Operating pressure	Code
10 bar	2
16 bar	3

4 Connection type	Code
PN 10 / flange EN 1092, face-to-face dimension FTF EN 558-1 series 49 (R90), series 16 (R91)	2
PN 16 / flange EN 1092, face-to-face dimension FTF EN 558-1 series 49 (R90), series 16 (R91)	3
PN 25 / flange EN 1092, face-to-face dimension FTF EN 558-1 series 49 (R90), series 16 (R91)	5

4 Connection type	Code
PN 40 / flange EN 1092, face-to-face dimension FTF EN 558-1 series 49 (R90), series 16 (R91)	6
ANSI B16.5, Class 150, face-to-face dimension FTF EN 558-1 series 49 (R90), series 16 (R91)	D

5 Body material	Code
EN-GJS-400-15 (GGG-40), epoxy coated, RAL 5010 (blue) (R91)	2
1.4408 / ASTM A351 / CF8M	4

6 Shut-off element material	Code
EN-GJS-400-15 (GGG-40), epoxy coated, RAL 5010 (blue) (R91)	2
1.4408 / ASTM A351 / CF8M	4
CC333G / 2.0975 / C954	G

7 Guide element material	Code
1.4401	6

8 Shut-off seal material	Code
NBR	N
FKM	V
EPDM (WRAS certification)	W

9 Spring material	Code
1.4571	6

10 Type of design	Code
Without	
Check valve with bonded O-ring	2577

Order example

Ordering option	Code	Description
1 Type	R91	Dual plate check valve, metal
2 DN	50	DN 50
3 Operating pressure	3	16 bar
4 Connection type	3	PN 16 / flange EN 1092, face-to-face dimension FTF EN 558-1 series 49 (R90), series 16 (R91)
5 Body material	2	EN-GJS-400-15 (GGG-40), epoxy coated, RAL 5010 (blue) (R91)
6 Shut-off element material	2	EN-GJS-400-15 (GGG-40), epoxy coated, RAL 5010 (blue) (R91)
7 Guide element material	6	1.4401
8 Shut-off seal material	W	EPDM (WRAS certification)
9 Spring material	6	1.4571
10 Type of design		Without

6 Technical data

6.1 Medium

Working medium: Corrosive, inert, gaseous and liquid media which have no negative impact on the physical and chemical properties of the body, plate and seal material.

The valves are not suitable for fluids containing solids.

6.2 Temperature

Media temperature:

Seal material.:
 NBR (Code N): -30 – 90 °C
 FKM (Code V): -15 – 200 °C
 EPDM (Code W)*: -15 – 120 °C

with special seal (on request) up to 300 °C
 * with WRAS drinking water approval up to 85 °C

Ambient temperature: -20 – 95 °C

6.3 Pressure

Operating pressure: max. 16 bar



Vacuum: Can be used up to a vacuum of 100 mbar (abs), or with bonded O-ring (K-no. 2577) up to a vacuum of 20 mbar (abs)

These values apply to room temperature and air. The values may deviate for other media and other temperatures.

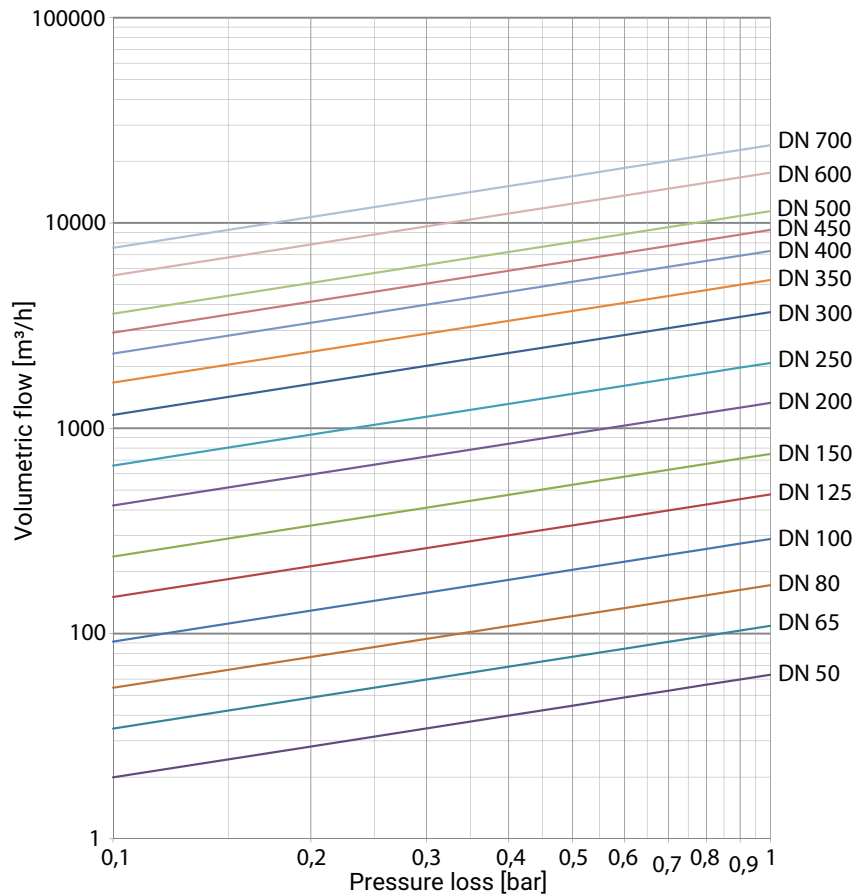
Pressure loss:



Pressure for disc opening:

DN	Piping		
			
50	~ 15	~ 20	~ 10
65	~ 15	~ 20	~ 10
80	~ 15	~ 20	~ 10
100	~ 15	~ 20	~ 10
125	~ 15	~ 20	~ 10
150	~ 15	~ 20	~ 10
200	~ 15	~ 20	~ 10
250	~ 15	~ 20	-
300	~ 15	~ 20	-
350	~ 15	~ 20	-
400	~ 15	~ 30	-
450	~ 15	~ 30	-
500	~ 15	~ 30	-
600	~ 15	~ 30	-

Pressures in mbar

Leakage rate:

A acc. to EN 12266-1 (with plastic seal)

G acc. to EN 12266-1 (metallic sealing)

Kv values:

DN	Kv values
50	63.0
65	109.0
80	172.0
100	289.0
125	476.0
150	750.0
200	1330.0
250	2080.0
300	3676.0
350	5274.0
400	7306.0
450	9246.0
500	11410.0
600	17570.0

Kv values in m³/h

6.4 Product conformities

Pressure Equipment Directive: 2014/68/EU

Drinking water:

WRAS*

* only with seal material EPDM up to 85 °C

6.5 Mechanical data

Weight:

DN	Weight
50	1.5
65	2.3
80	3.6
100	4.4
125	6.0
150	8.6
200	15.2
250	24.0
300	35.2
350	58.0
400	74.6
450	98.0
500	125.0
600	170.0

Weights in kg

7 Dimensions

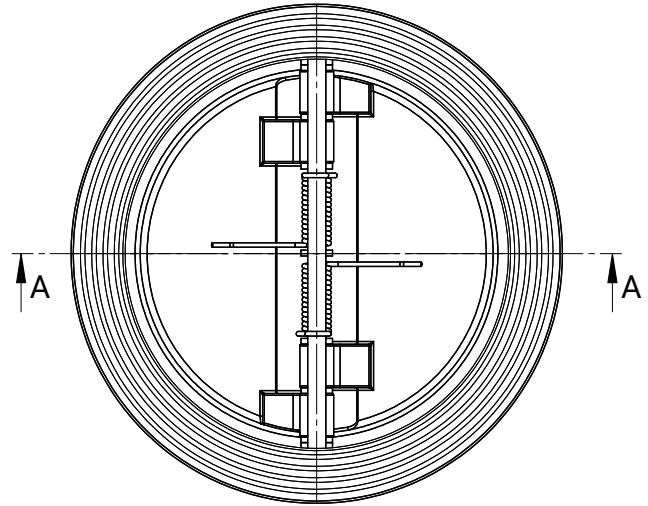
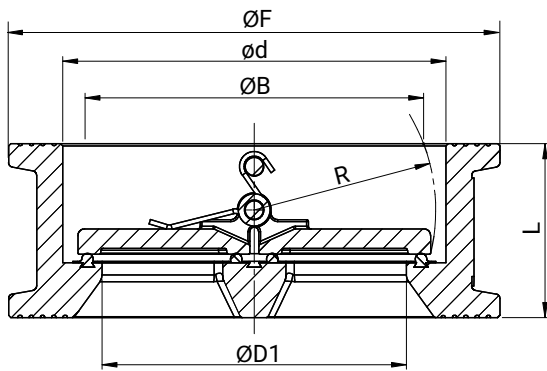

DN	ØB	ød	ØD1	± ØD1	R ± 2	Connection					Length	
						PN 10 (code 2)	PN 16 (code 3)	PN 25 (code 5)	PN 40 (code 6)	ANSI 150 (code D)	EN 558-1	API 594
						ØF					L	
50	43.5	70.5	43.0	1.4	30.5	107.0	107.0	107.0	-	101.0	43.0	60.0
65	51.2	80.0	60.0	1.4	36.2	127.0	127.0	127.0	-	121.0	46.0	67.0
80	51.5	98.0	70.0	1.6	43.2	142.0	142.0	142.0	-	134.0	64.0	73.0
100	84.9	117.0	85.0	1.6	51.4	162.0	162.0	168.0	-	171.0	64.0	73.0
125	114.7	145.0	115.0	1.8	64.7	192.0	192.0	192.0	-	193.0	70.0	-
150	139.9	172.0	134.0	1.8	77.6	218.0	218.0	218.0	-	219.0	76.0	98.0
200	185.6	221.0	176.0	2.0	99.7	273.0	273.0	276.0	276.0	276.0	89.0	127.0
250	228.1	275.5	218.0	2.0	124.5	328.0	328.0	336.0	336.0	336.0	114.0	146.0
300	286.9	325.5	255.0	2.2	149.8	378.0	383.0	400.0	-	406.0	114.0	181.0
350	322.5	360.0	293.0	2.2	167.5	438.0	444.0	448.0	448.0	448.0	127.0	184.0
400	369.1	410.0	350.0	2.2	192.0	489.0	495.0	511.0	511.0	511.0	140.0	191.0
450	413.3	467.0	383.0	2.2	215.0	539.0	555.0	555.0	-	546.0	152.0	203.0
500	464.7	515.0	432.0	2.5	240.0	594.0	617.0	617.0	-	603.0	152.0	219.0
600	568.0	624.0	538.0	2.5	292.5	695.0	734.0	730.0	-	714.0	178.0	222.0

Dimensions in mm

8 Manufacturer's information

8.1 Delivery

- Check that all parts are present and check for any damage immediately upon receipt.

The product's performance is tested at the factory. The scope of delivery is apparent from the dispatch documents and the design from the order number.

8.2 Packaging

The product is packaged in a cardboard box which can be recycled as paper.

8.3 Transport



1. Only transport the product by suitable means. Do not drop. Handle carefully.
2. After the installation dispose of transport packaging material according to relevant local or national disposal regulations / environmental protection laws.

8.4 Storage



1. Store the product free from dust and moisture in its original packaging.
2. Avoid UV rays and direct sunlight.
3. Do not exceed the maximum storage temperature (see chapter "Technical data").
4. Do not store solvents, chemicals, acids, fuels or similar fluids in the same room as GEMÜ products and their spare parts.



9 Installation in piping

9.1 Preparing for installation

 DANGER	
	<p>Risk of crushing!</p> <ul style="list-style-type: none"> ▶ Risk of severe injury. ● Depressurize the plant before performing any work on the product. ● Observe correct handling procedures.

 WARNING	
The equipment is subject to pressure!	
<ul style="list-style-type: none"> ▶ Risk of severe injury or death ● Depressurize the plant. ● Completely drain the plant. 	

 WARNING	
	<p>Corrosive chemicals!</p> <ul style="list-style-type: none"> ▶ Risk of caustic burns ● Wear appropriate protective gear. ● Completely drain the plant.

 CAUTION	
	<p>Hot plant components!</p> <ul style="list-style-type: none"> ▶ Risk of burns ● Only work on plant that has cooled down.

 CAUTION	
Exceeding the maximum permissible pressure.	
<ul style="list-style-type: none"> ▶ Damage to the product ● Provide precautionary measures against exceeding the maximum permitted pressures caused by pressure surges (water hammer). 	

 CAUTION	
Use as step.	
<ul style="list-style-type: none"> ▶ Damage to the product ▶ Risk of slipping-off ● Choose the installation location so that the product cannot be used as a foothold. ● Do not use the product as a step or a foothold. 	

NOTICE	
Suitability of the product!	
<ul style="list-style-type: none"> ▶ The product must be appropriate for the piping system operating conditions (medium, medium concentration, temperature and pressure) and the prevailing ambient conditions. 	

NOTICE	
Tools	
<ul style="list-style-type: none"> ▶ The tools required for installation and assembly are not included in the scope of delivery. ● Use appropriate, functional and safe tools. 	

1. Ensure the product is suitable for the relevant application.
2. Check the technical data of the product and the materials.
3. Keep appropriate tools ready.
4. Wear appropriate protective gear, as specified in the plant operator's guidelines.
5. Observe appropriate regulations for connections.
6. Have installation work carried out by trained personnel.
7. Shut off plant or plant component.
8. Secure plant or plant component against recommissioning.
9. Depressurize the plant or plant component.
10. Completely drain the plant (or plant component) and let it cool down until the temperature is below the media vaporization temperature and cannot cause scalding.
11. Correctly decontaminate, rinse and ventilate the plant or plant component.
12. Lay piping so that the product is protected against transverse and bending forces, and also from vibrations and tension.
13. Only install the product between matching aligned pipes (see chapters below).
14. Pay attention to the installation position: horizontal or vertical.
15. Pay attention to the direction of the working medium: positioned in-line with flow direction

9.2 Installation

1. Carry out preparations for installation (see chapter "Preparing for installation").
2. Inspect check valve and suitable gaskets for possible damage before installation. Check the check valve for freedom of movement. Damaged parts must not be installed.
3. Make sure that you only install check valves whose pressure class, chemical resistance, connection and dimensions are appropriate for the conditions of use.
4. Provide a straight pipe section of at least five times the nominal diameter upstream and downstream of the check valve.

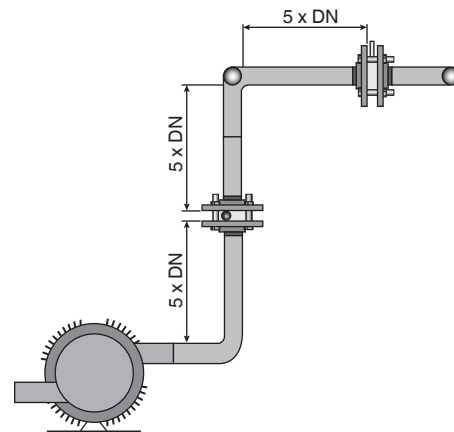

5. Use flanges to EN1092-1 or EN1092-2 for metal piping.
6. Do not mount directly on a pump flange.
7. Avoid pulsating flow conditions and water hammer.
8. Observe the flow direction of the check valve.
9. Tighten flange bolts to the appropriate torque in a diagonal pattern.

Flange bolt torques	
Thread	Torque [Nm]
M10	30
M12	50
M16	130
M 20	250
M24	420
M27	600
M30	850
M33	1100
M36	1500

10 Commissioning

WARNING



Corrosive chemicals!

- ▶ Risk of caustic burns
- Wear appropriate protective gear.
- Completely drain the plant.

CAUTION

Leakage

- ▶ Emission of dangerous materials.
 - Provide precautionary measures against exceeding the maximum permitted pressures caused by pressure surges (water hammer).
1. Check the tightness and the function of the product (close and reopen the product).
 2. Flush the piping system of new plant and following repair work (the product must be fully open).
 - ⇒ Harmful foreign matter has been removed.
 - ⇒ The product is ready for use.
 3. Commission the product.

11 Troubleshooting

Error	Possible cause	Troubleshooting
Excessive noise	Settling section not complied with	Install valve in a suitable position
	Flow rate too low	Select smaller nominal size
No flow present	Valve installed wrong way round	Align flow direction arrow with flow direction
	Too low flow rate	Increase pressure/flow rate
	Disc stuck	Clean or replace valve
	Closing spring too strong	Use a weaker closing spring
Leakage rate too high	O-ring damage	Replace O-ring
	Disc deformed	Replace disc
	Sealing surface damaged	Revise sealing surface, replace housing if necessary
	Sealing surface contaminated	Clean sealing surface
	Wear	Replace affected components
	Closing spring worn/defective	Replace closing spring
Leakage at flange	Flange not sufficiently tightened	Check connector elements and retighten if necessary
	Sealing surface/seal damaged	Revise sealing surface, replace housing/seal if applicable
	Sealing surface/seal contaminated	Clean sealing surface/seal

12 Inspection and maintenance

⚠ WARNING

The equipment is subject to pressure!

- ▶ Risk of severe injury or death
- Depressurize the plant.
- Completely drain the plant.

⚠ CAUTION



Hot plant components!

- ▶ Risk of burns
- Only work on plant that has cooled down.

⚠ CAUTION

- Servicing and maintenance work must only be performed by trained personnel.
- GEMÜ shall assume no liability whatsoever for damage caused by improper handling or third-party actions.
- In case of doubt, contact GEMÜ prior to commissioning.

⚠ CAUTION

Pretensioned spring!

- ▶ Damage to the device.
- Slowly release the tension in the spring.

The operator must carry out regular visual examination of the GEMÜ products dependent on the operating conditions and the potential danger in order to prevent leakage and damage.

The product also must be disassembled and checked for wear in the corresponding intervals.

1. Have servicing and maintenance work performed by trained personnel.
2. Wear appropriate protective gear as specified in plant operator's guidelines.
3. Shut off plant or plant component.
4. Secure the plant or plant component against recommissioning.
5. Depressurize the plant or plant component.
6. Actuate GEMÜ products which are always in the same position four times a year.

12.1 Spare parts

The product can only be repaired at GEMÜ. The replacement of spare parts may only be carried out by GEMÜ. If this procedure is not observed, the purchaser's guarantee rights and the manufacturer's legal liability cease. This can also lead to a loss of all rights to claim damages.

⚠ CAUTION



Replacement of spare parts

- ▶ Damage to the GEMÜ product.
- Do not dismantle the product but send it completely to GEMÜ.

1. Remove the product completely from the plant using appropriate tools.
2. Send the product with return declaration to GEMÜ (see "Returns", page 17).

13 Removal from piping

NOTICE

- ▶ If defective, the entire product must be replaced.

1. Observe (see "Safety information", page 5) the safety information.
2. Undo the nuts **6** of all flange bolts **1**.
3. Fully remove all of the nuts **6** and washers **2** from the flange bolts **1**.
4. Pull the flange bolts **1** out of the flange holes.
 - ⇒ For a horizontal flow, the bottom flange bolts **1** can remain inserted in order to facilitate disassembly.
5. Secure the check valve **5** against falling down.
6. Pull the flange bolts **1** out of the flange holes.
7. Remove the check valve **5** out of the flange **3** (for large valves, use a lifting gear and a suitable lifting tackle).
8. Remove the remaining flange bolts **1** out of the flange holes.
9. Place the check valve down **5** on a suitable underlay.
10. Insert and centre the new check valve **5** with new seals **4**.
11. Tighten the flange bolts **1**.

14 Disposal

1. Pay attention to adhered residual material and gas diffusion from penetrated media.
2. Dispose of all parts in accordance with the disposal regulations/environmental protection laws.

15 Returns

Legal regulations for the protection of the environment and personnel require that the completed and signed return delivery note is included with the dispatch documents. Returned goods can be processed only when this note is completed. If no return delivery note is included with the product, GEMÜ cannot process credits or repair work but will dispose of the goods at the operator's expense.

1. Clean the product.
2. Request a return delivery note from GEMÜ.
3. Complete the return delivery note.
4. Send the product with a completed return delivery note to GEMÜ.

16 Declaration of Incorporation according to 2006/42/EC (Machinery Directive)



EU Declaration of Incorporation

according to the EC Machinery Directive 2006/42/EC, Annex II B

We, the company GEMÜ Gebr. Müller Apparatebau GmbH & Co. KG
Fritz-Müller-Strasse 6-8
74653 Ingelfingen-Criesbach, Germany

hereby declare under our sole responsibility that the below-mentioned product complies with the relevant essential health and safety requirements in accordance with Annex I of the above-mentioned Directive.

Product: GEMÜ R91
Product name: Metal dual plate check valve
The following essential health and safety requirements of the EC Machinery Directive 2006/42/EC, Annex I have been applied or adhered to: 1.1.2.; 1.1.3.; 1.3.2.; 1.3.4.; 1.3.7.; 1.5.13.; 1.5.4.; 1.5.5.; 1.5.7.; 1.5.8.; 1.6.1.; 1.6.5.; 1.7.1.; 1.7.1.1.; 1.7.2.; 1.7.3.; 1.7.4.; 1.7.4.1.; 1.7.4.2.; 1.7.4.3.
The following harmonized standards (or parts thereof) have been applied: EN ISO 12100:2010

We also declare that the specific technical documents have been created in accordance with part B of Annex VII.
The manufacturer undertakes to transmit relevant technical documents on the partly completed machinery to the national authorities in response to a reasoned request. This communication takes place electronically.
This does not affect the industrial property rights.

The partly completed machinery may be commissioned only if it has been determined, if necessary, that the machinery into which the partly completed machinery is to be installed meets the provisions of the Machinery Directive 2006/42/EC.

M. Barghoorn
Head of Global Technics

Ingelfingen, 25/07/2023

17 Declaration of conformity according to 2014/68/EU (Pressure Equipment Directive)



EU Declaration of Conformity

in accordance with 2014/68/EU (Pressure Equipment Directive)

We, the company GEMÜ Gebr. Müller Apparatebau GmbH & Co. KG
Fritz-Müller-Strasse 6-8
74653 Ingelfingen-Criesbach, Germany

hereby declare under our sole responsibility that the below-mentioned product complies with the regulations of the above-mentioned Directive.

Product: GEMÜ R91
Product name: Metal dual plate check valve
Applied conformity assessment procedure(s): Module H
The following harmonized standards (or parts thereof) have been applied: EN 16668:2016 + A1:2018

Information for products with a nominal size \leq DN 25:

The products are developed and produced according to GEMÜ's in-house process instructions and standards of quality which comply with the requirements of ISO 9001 and ISO 14001. According to Article 4, Paragraph 3 of the Pressure Equipment Directive 2014/68/EU, these products must not be identified by a CE-marking.

M. Barghoorn
Head of Global Technics
Ingelfingen, 25/07/2023



GEMÜ Gebr. Müller Apparatebau GmbH & Co. KG
Fritz-Müller-Straße 6-8, 74653 Ingelfingen-Criesbach, Germany
Phone +49 (0) 7940 1230 · info@gemue.de
www.gemu-group.com

Subject to alteration

08.2023 | 88726336