

# GEMÜ 1010 hand lever

## for GEMÜ 650

Hand lever for sampling, factory mounted to GEMÜ 650, actuator size OT1.

### Advantages

- Fast, uncomplicated sampling
- Defined closing force via the spring which considerably increases the service life of the diaphragm

### Dead man's version

- The valve is closed as soon as the lever is released

### Fast-switching facility with locking device

- 'Hold-open' function for autoclaving the entire valve
- Accidental lever operation prevented by spring cotter pin

GEMÜ 1010



GEMÜ 650

## Dimensions [mm]

### Dead man's version

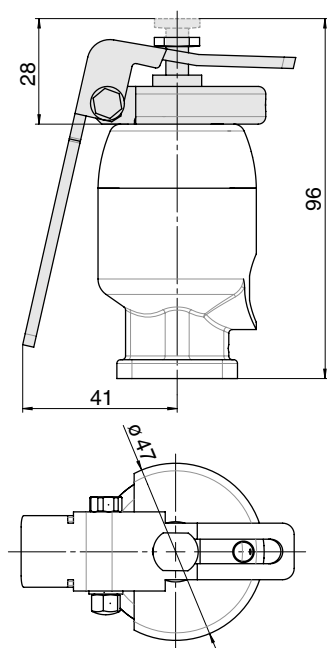

### Fast-switching facility with locking device

#### 'Hold-closed' function

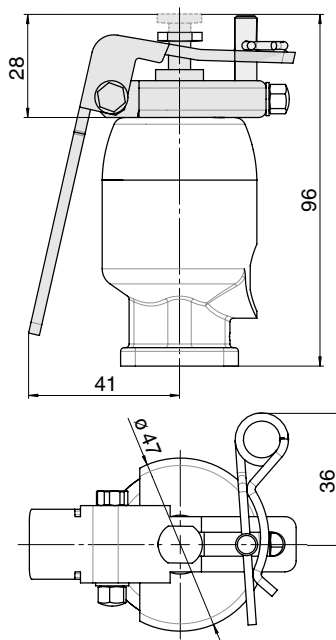

#### 'Hold-open' function

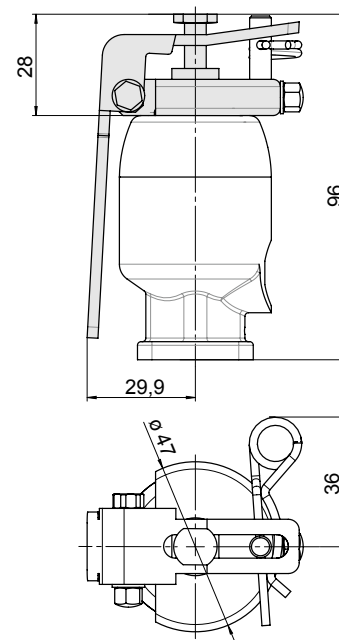

Order code 1010 000Z 05 01 070 TM

Order code 1010 000Z 05 01 070 SA

### Note

The GEMÜ 1010 hand lever can only be ordered factory-mounted to the GEMÜ 650 diaphragm valve (diaphragm size 8, control function 1, actuator size OT1).

For order options and technical data of GEMÜ 650 with actuator size OT1 please refer to the current datasheet. Please specify both order codes (for GEMÜ 650 and GEMÜ 1010) when ordering.

Attention: The hand lever is not available for other versions of the GEMÜ 650 diaphragm valve.

The plastic sleeve on the hand lever cannot be autoclaved but can be removed if necessary.

All rights including copyright and industrial property rights are expressly reserved.

Should there be any doubts or misunderstandings, the German version of this data sheet is the authoritative document!

Subject to alteration · 01/2014 · 88420954

**GEMÜ**® VALVES, MEASUREMENT  
AND CONTROL SYSTEMS

