

Vridspjällsventil Metall

Konstruktion

GEMÜ Victoria® är en centrisk vridspjällsventil med spjälltätning av elastomer. Den finns i nominella diametrar DN 25–600 och i de olika husvarianterna wafer, lug och U-typ. Vridspjällsventilen finns med olika typer av manöverdon: GEMÜ 487 med handspak eller drivenhet, GEMÜ 481 med pneumatiskt manöverdon, GEMÜ 488 med elmotordrivet manöverdon för öppen/stängd eller reglering.

Egenskaper

- Lämpad för användning i gasformiga och flytande medier inom industri och vattenrening
- Inbyggnadslängd enligt ISO 5752/20, EN 558-1/20, API 609 kategori A
- Topplåns enligt EN ISO 5211
- Max. drifttryck 3/10/16 bar
- Anslutningsstandarder PN 10, PN 16, ASME B16.5 cl. 150
- Bruksstandard EN 593
- Täthetskontroll enligt EN 12266-1/P12 läckagegrad A
- Vridspjällsventilen uppfyller säkerhetsbestämmelserna i bilaga I i det europeiska direktivet för tryckbärande utrustning 2014/68/EU för fluider i grupp 1 och 2
- Kan som tillval levereras i utförande för ATEX och fri från ämnen som förstör lackets vätningsförmåga

Fördelar

- Förbättrad tätning tack vare särskild tätningsgeometri även vid stora nominella diametrar
- Brett användningsområde tack vare stort urval av material
- Modulär konstruktion
- Enkel montering
- Lågt vridmoment
- Godkännande för dricksvatten (DVGW, ACS, Belgaqua)
- Ventilhusets ytbehandling jämförbar ISO 12944-6 C5
- Kan användas i havsnära och offshore-områden, samt i byggnader med höga grader kondensation och föroreningar

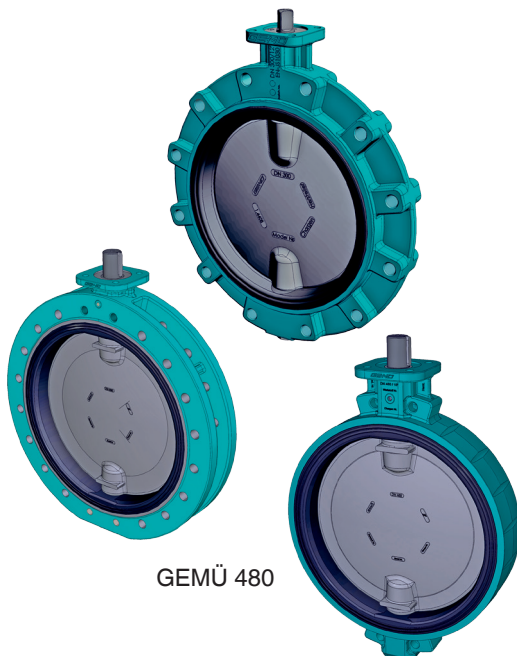

GEMÜ 480



GEMÜ 487



GEMÜ 481



GEMÜ 488

Tekniska data

Processmedium

Gasformiga och flytande medier som inte påverkar de fysikaliska och kemiska egenskaperna hos spjällskivans och tätningens material negativt.

Omgivningsförutsättningar

Tillåten omgivningstemperatur -10 till 70°C

Tillåten temperatur för processmediet

-10 till 150°C beroende på spjälltätningens material

Andra temperaturer på begäran

Tryckslag får inte förekomma

Vakuüm

Lös spjälltätning:
kan användas för vakuüm till 900 mbar (absolut)

Fastlimmad spjälltätning:
kan användas för vakuüm till 20 mbar (absolut)

Dessa värden gäller för rumstemperatur och luft. Värdena kan avvika för andra medier och temperaturer.

Max. tillåtet tryck för processmedium

PS	Fluidgrupp 1		Fluidgrupp 2	
	Gaser	Vätskor	Gaser	Vätskor
16 bar	DN 25 - 200	DN 25 - 200	DN 25 - 200	DN 25 - 200
10 bar	DN 250 - 350	DN 250 - 600	DN 250 - 500	DN 250 - 600
6 bar	-	-	DN 600	-
3 bar	DN 200 - 350	DN 200 - 600	DN 200 - 600	DN 200 - 600

Vid användning (montering) som ändventil är det maximala driftrycket för vätskor DN 50-200 10 bar
DN 250-600 6 bar

Vid användning som ändventil krävs det att en motfläns monteras.

Vridmoment/Kv-värden

DN	PS [bar]	Vridmoment* [Nm]	Kv-värden [m ³ /h] vid öppningsvinkel							
			20°	30°	40°	50°	60°	70°	80°	90°
25	16	4	0,7	2	4,1	7,2	11	14,5	16,6	17,2
40		7	2,5	7	14,4	25,1	38,3	50,6	57,8	60
50		7	3,4	8,5	20	33	52	80	90	91
65		15	8,5	15	30	64	95	129	142	147
80		28	19	40	66	117	168	250	275	283
100		55	29	75	137,0	213	316	432	518	548
125		77	48	100	185	315	470	660	785	826
150		118	60	150	281	450	702	1039	1325	1407
200	242	110	281	472	759	1210	1835	2360	2482	
250	10	310	200	444	738	1187	1886	2918	3902	4072
300		330	250	946	1064	1668	2539	3860	5400	5420
350		430	466	1036	1721	2767	4397	6803	9097	9494
400		1035	644	1431	2376	3820	6072	9394	12561	13110
450		1150	1039	2308	3834	6163	9796	15154	20264	21149
500		1250	1083	2406	3997	6425	10213	15800	21127	22050
600		2140	1563	3473	5770	9276	14744	22809	30500	31832
200		3	145	110	281	472	759	1210	1835	2360
250	152		200	444	738	1187	1886	2918	3902	4072
300	245		250	946	1064	1668	2539	3860	5400	5420
350	255		466	1036	1721	2767	4397	6803	9097	9494
400	580		644	1431	2376	3820	6072	9394	12561	13110
450	600		1039	2308	3834	6163	9796	15154	20264	21149
500	860		1083	2406	3997	6425	10213	15800	21127	22050
600	1440		1563	3473	5770	9276	14744	22809	30500	31832

Vid en öppningsvinkel under 30° bör ingen reglering ske!

* Processmedium vatten (20°C) och optimala driftförhållanden

För vridspjällsventil med fastlimmad tätning måste vridmomentet multipliceras med 1,3.

För vridspjällsventil med EPDM-tätning (kod T) måste vridmomentet multipliceras med 1,44.

Produktöverensstämmelser

Överensstämmelser	Tillåtna utföranden			Beställningskod specialfunktion
	Material spjällskiva	Material spjälltätning	Fixering	
Dricksvatten				
DVGW vatten (W270, KTW)	CF8M, 1.4408 (kod A) CF8M, 1.4408 polerad (kod B)	EPDM (kod W)	Lös (kod L)	D
ACS	CF8M, 1.4408, (kod A) CF8M, 1.4408 polerad (kod B) Super Duplex, 1.4469 (kod D) EN-GJS-400-15,GGG40 Rilsan® PA11-beläggning (kod R)	EPDM (kod W)	Lös (kod L)	A
WRAS	CF8M, 1.4408 (kod A) CF8M, 1.4408 polerad (kod B)	EPDM (kod W)	alla versioner	W
Belgaqua	CF8M, 1.4408, (kod A) CF8M, 1.4408 polerad (kod B) Super Duplex, 1.4469 (kod D)	EPDM (kod W)	Lös (kod L)	B
Gas				
DVGW Gas *	CF8M, 1.4408 (kod A) CF8M, 1.4408 polerad (kod B)	NBR (kod J)	Lös (kod L)	G
FDA				
FDA	CF8M, 1.4408, (kod A) CF8M, 1.4408 polerad (kod B) Super Duplex, 1.4469 (kod D)	EPDM, vit (kod M) EPDM HT (kod Z)	Lös (kod L)	ingen beställningskod krävs
EG-förordning 1935/2004	CF8M, 1.4408 polerad (kod B)	EPDM, vit (kod M)	alla versioner	ingen beställningskod krävs
Fartygsgodkännande				
DNVGL	alla material	alla material utom SBR	alla versioner	S
Explosionsskydd				
ATEX *	alla material	alla material	alla versioner	X

övriga egenskaper saknar relevans för godkännanden
* endast GEMÜ 480

Konstruktion

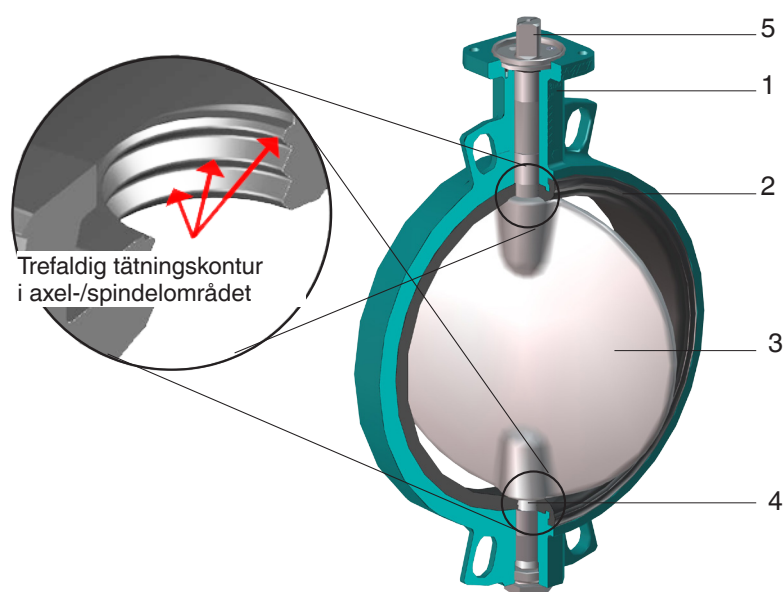

Pos.	Beteckning
1	Ventilhus
2	Spjälltätning
3	Spjällskiva
4	Axel
5	Spindel och lägesindikering

Beställningsuppgifter

1 Typ	Kod
Vridspjäll med fri axelände	480
Vridspjällsventil med pneumatiskt manöverdon	481
Vridspjällsventil med manuell manöverdon	487
Vridspjällsventil med elektriskt manöverdon	488

2 Nominell diameter	Kod
DN 25–DN 600	025–600

3 Ventilhus	Kod
Wafer (DN 25–DN 600)	W
Lug (DN 50–DN 400)	L
U-sektion (DN 400–DN 600)	U

4 Driftryck (husmaterial EN-GJS 400-15)		DN	25	40	50	65	80	100	125	150	200	250	300	350	400	450	500	600
PS 3 bar*	Kod										0	0	0	0	0	0	0	0
PS 10 bar	Kod	2	2	2	2	2	2	2	2	2	2	2	2	2	2	2	2	2
PS 16 bar	Kod	3	3	3	3	3	3	3	3	3	3							
Standard																		

* endast material – spjällskiva kod A

5 Anslutning		DN	25	40	50	65	80	100	125	150	200	250	300	350	400	450	500	600
Wafer	PN 6	Kod	3	3	3	3	3	3	3	3	3	3						
	PN 10	Kod	3	3	3	3	3	3	3	3	3	3	3	3	3	2	3	2
	PN 16	Kod	3	3	3	3	3	3	3	3	3	3	3	3	3	3	3	3
Lug	PN 10	Kod			3	3	3	3	3	3	2	2	2	2	2			
	PN 16	Kod			3	3	3	3	3	3	3	3	3	3	3			
U-Sektion	PN 10	Kod													2	2	2	2
	PN 16	Kod													3	3	3	3
Standard																		

För fler anslutningar, se sidan 11

6 Material – ventilhus	Kod
EN-GJS-400-15 (GGG 40), epoxibeläggning 250 µm (RAL 5021)	2

10 Fixering	Kod
Lös spjälltätning (standard)	L
Fastlimmad spjälltätning	B

7 Material – spjällskiva	Kod
CF8M, 1.4408	A
EN-GJS-400-15 (GGG40), epoxibeläggning (-10 till 80°C)	E
CF8M, 1.4408 Halar-beläggning (-10 till 150°C)	C
CF8M, 1.4408 polerad	B
Super Duplex, 1.4469	D
EN-GJS-400-15 (GGG 40), Halar-beläggning	P
EN-GJS-400-15 (GGG40), Rilsan® PA11-beläggning (-10 till 100°C)	R

11 Styrfunktion	Kod
Vridspjällsventil med fri axelände (typ 480)	F
Vridspjällsventil med manuell manöverdon (typ 487)	0
Stängs med fjäderkraft (NC) (typ 481)	1
Öppnas med fjäderkraft (NO) (typ 481)	2
Dubbelverkande (DA) (typ 481)	3
Stängd i viloläge (NC), manöverdonet är monterat vinkelrätt mot rörledningen (typ 481)	Q
Dubbelverkande (DA), manöverdonet är monterat vinkelrätt mot rörledningen (DA) (typ 481)	T
Öppen i viloläge (NO), manöverdonet är monterat vinkelrätt mot rörledningen (typ 481)	U

8 Material – spindel	Kod
AISI 420/1.4021	1

12 Manöverdonsstorlek	Kod
480 (rubrik 12)	se sidan 11
481 (rubrik 12)	från sidan 17
487 (rubrik 12)	från sidan 12
488 (rubrik 14, 15, 16)	från sidan 29

9 Material – spjälltätning	Kod
EPDM -10 till +120°C	E
Flucast AB/P -10 till +70°C	F
NBR (DVGW-gascertifiering) -10 till +60°C	J
Vit EPDM (FDA-godkännande) -10 till +95°C	M
NBR -10 till +100°C	N*
FPM -10 till +150°C	V*
EPDM (ACS, Belgaqua och DVGW-vattengodkännande) -10 till +95°C	W
EPDM HT (FDA-godkännande) -10 till +130°C	Z
* Driftryck max. 10 bar	
Andra material på begäran	

13 Specialfunktion	Kod
DVGW vatten	D
DVGW gas	G
ACS	A
Belgaqua	B
ATEX	X
WRAS	W
se tabell sidan 3	

Beställningsexempel	1	2	3	4	5	6	7	8	9	10	11	12	13
Kod	487	100	W	3	3	2	A	1	E	L	0	AHL14	-
Andra utföranden och material på begäran													

Ventilhusets mått [mm]

Ventilhusstyp wafer (kod W)

DN	A	B	C	D	E		H* max	øS max	I	□G		ISO	a	øb	f	øy	Vikt [kg]
					PS10 PS16	PS3				PS10 PS16	PS3						
25	100	41,3	25	59,5	19	-	16,0	26,5	0,5	9	-	F05	□50	50	12	7	1,2
40	120	53,8	33	75,8	19	-	24,5	41,5	4,0	9	-	F05	□50	50	12	7	1,5
50	120	60,2	43	91,0	19	-	27,4	51,5	4,0	9	-	F05	ø65	50	12	7	3,0
65	140	67,6	46	111	19	-	47,6	66,7	10,1	11	-	F05	ø65	50	12	7	3,6
80	145	90,4	46	130	19	-	66,9	81,7	17,6	11	-	F05	ø65	50	12	7	4,0
100	166	105,1	52	150	19	-	87,1	101,9	24,7	14	-	F05	ø65	50	14	7	5,5
125	187	119,6	56	179	25	-	113,3	126,9	35,2	17	-	F07	ø90	70	16	9	7,5
150	200	131,5	56	210	25	-	140,7	151,9	47,7	17	-	F07	ø90	70	16	9	8,6
200	240	160,0	60	264	32	25	192,7	202,3	70,9	22	17	F10	ø125	102	17	11	12,7
250	265	195,3	68	314	32	25	242,4	252,3	91,9	22	17	F10	ø125	102	17	11	22,2
300	290	236,3	78	364	32	25	292,3	303,0	112,2	22	17	F10	ø125	102	17	11	30,8
350	321	266,0	78	440	28	28	329,0	337,4	130,0	27	22	F12	□130	125	15	13	48,0
400	347	308,0	102	485	37	28	379,0	391,4	145,0	36	27	F14	□160	140	20	17	72,0
450	372	333,0	114	541	37	28	428,0	441,4	164,0	36	27	F14	□160	140	20	17	95,0
500	398	358,0	127	600	37	28	478,0	493,4	183,5	36	27	F14	□160	140	20	17	120,0
600	470	442,0	154	700	47	37	574,0	593,4	220,0	46	36	F16	□200	165	24	21	192,0

*vid användning av plastledning, beakta spjällskivans utloppsmått H

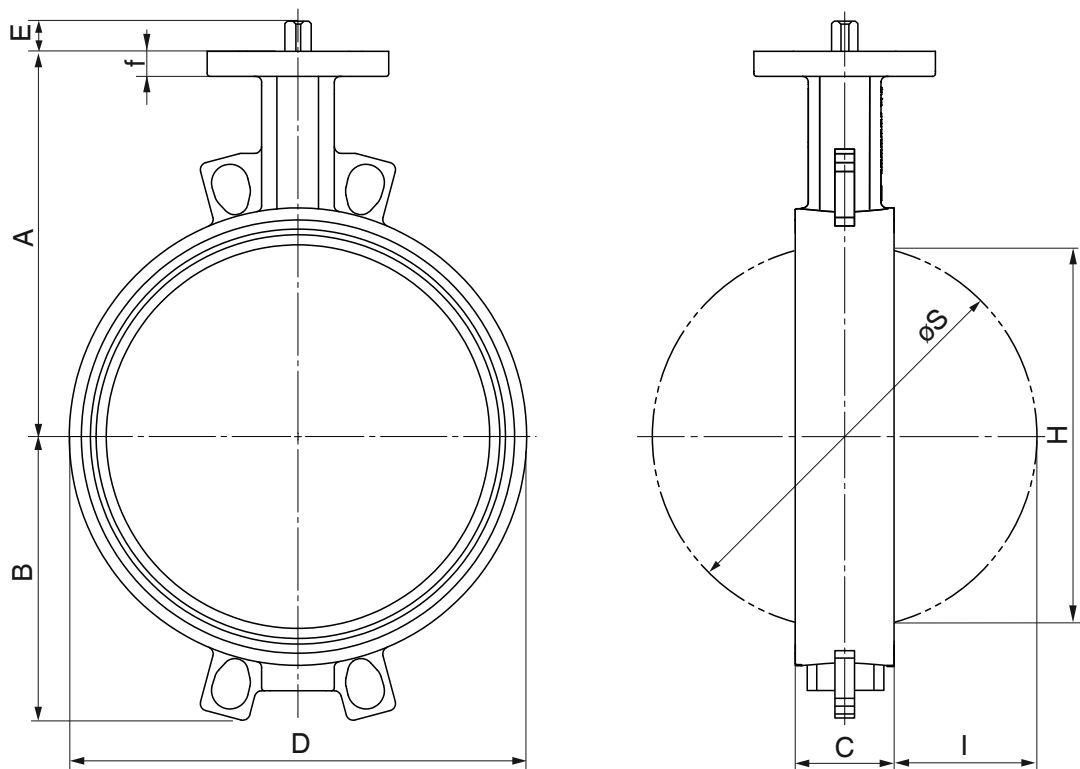

DN 25, 40, 350 - 600

DN 50 - 300

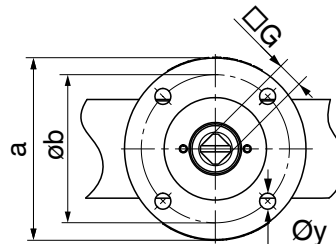
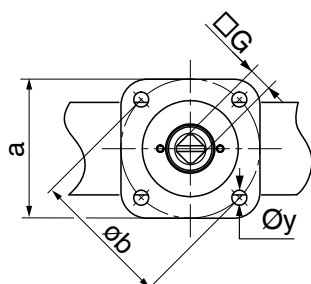

Ventilhustyp lug (kod L)

DN	A	B	C	D	E		H* max	øS max	I	□G		ISO	□a	øb	f	øy	Vikt [kg]
					PS10 PS16	PS3				PS10 PS16	PS3						
50	120	60,0	43	151,0	19	-	27,4	51,5	4,0	9	-	F05	50	50	12	7	3,7
65	140	67,0	46	171,0	19	-	47,6	66,7	10,1	11	-	F05	50	50	12	7	4,0
80	145	89,0	46	188,0	19	-	66,9	81,7	17,6	11	-	F05/F07	75	50/70	12	7/9	7,0
100	166	103,0	52	218,5	19	-	87,1	101,9	24,7	14	-	F05/F07	75	50/70	14	7/9	7,5
125	187	119,0	56	250,0	25	-	113,3	126,9	35,2	17	-	F07	75	70	16	9	11,0
150	200	130,5	56	275,0	25	-	140,7	151,9	47,7	17	-	F07	75	70	16	9	14,0
200	240	170,5	60	330,0	32	25	192,7	202,3	70,9	22	17	F10	100	102	17	11	21,0
250	265	203,0	68	402,0	32	25	242,4	252,3	91,9	22	17	F10	100	102	17	11	32,0
300	290	236,0	78	472,0	32	25	292,3	302,6	112,2	22	17	F10	100	102	17	11	43,0
350	321	260,0	78	520,0	28	28	329,0	337,4	130,0	27	22	F12	130	125	15	13	66,0
400	347	300,0	102	596,0	37	28	379,0	391,4	145,0	36	27	F14	160	140	20	17	110,0

*vid användning av plastledningar, beakta spjällskivans utloppsmått H

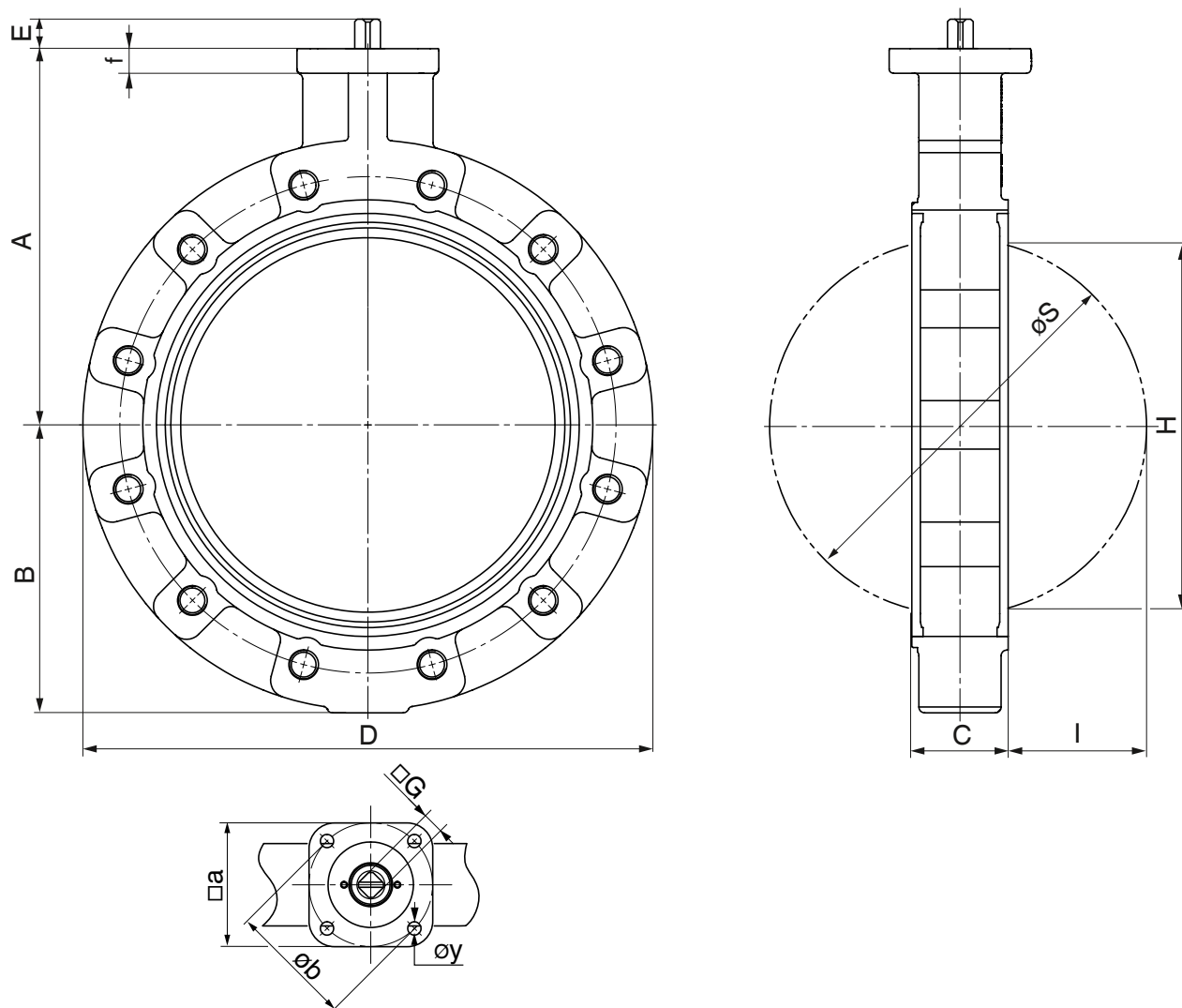

Ventilstyp U-sektion (kod U)

DN	A	B	C	D	E		H* max	øS max	I	□G		ISO	□a	øb	f	øy	Vikt [kg]
					PS10	PS3				PS10	PS3						
400	347	315	102	596	37	28	379	391,4	145,0	36	27	F14	160	140	20	17	107
450	372	340	114	640	37	28	428	441,4	164,0	36	27	F14	160	140	20	17	125
500	398	365	127	715	37	28	478	493,4	183,5	36	27	F14	160	140	20	17	164
600	470	447	154	840	47	37	574	593,4	220,0	46	36	F16	200	165	24	21	261

*vid användning av plastledningar, beakta spjällskivans utloppsmått H

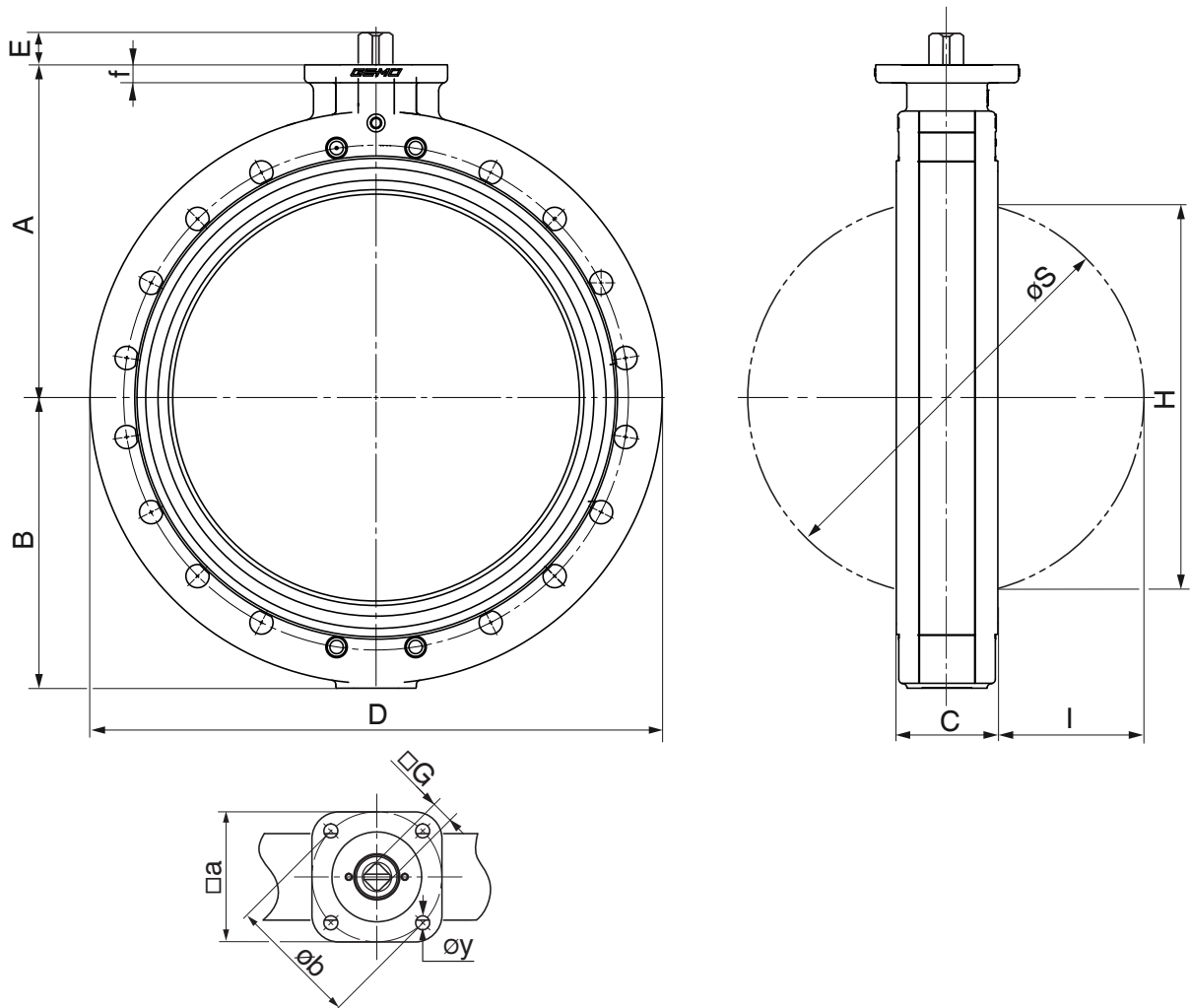

Anslutningsmått [mm]

Ventilstyp wafer (kod W)

DN	E	PN 10					PN 16					ASME B16.5 cl. 150				
		e	L	L1	n	G	e	L	L1	n	G	e	L	L1	n	G
25	25	18	85	100	4	M12	18	85	100	4	M12	14,3	85	100	4	1/2"-13 UNC
40	33	18	90	110	4	M16	18	90	110	4	M16	17,5	90	110	4	1/2"-13 UNC
50	43	18	100	120	4	M16	18	100	120	4	M16	19,0	100	120	4	5/8"-11 UNC
65	46	18	100	120	4	M16	18	100	120	4	M16	22,2	110	130	4	5/8"-11 UNC
80	46	20	110	130	8	M16	20	110	130	8	M16	23,8	110	130	4	5/8"-11 UNC
100	52	20	110	130	8	M16	20	110	130	8	M16	23,8	120	140	8	5/8"-11 UNC
125	56	22	120	140	8	M16	22	120	140	8	M16	23,8	130	150	8	3/4"-10 UNC
150	56	22	130	150	8	M20	22	130	150	8	M20	25,4	130	150	8	3/4"-10 UNC
200	60	24	130	160	8	M20	24	130	160	8	M20	28,6	140	160	8	3/4"-10 UNC
250	68	26	150	170	12	M20	26	150	170	12	M24	30,2	160	180	12	7/8"- 9 UNC
300	78	26	160	180	12	M20	28	160	180	12	M24	31,7	170	190	12	7/8"- 9 UNC
350	78	26	170	180	16	M20	30	170	190	16	M24	34,9	180	200	12	1"- 8 UNC
400	102	26	180	210	16	M24	32	200	220	16	M27	36,5	210	230	16	1"- 8 UNC
450*	114	26	190	220	16	M24	32	210	240	16	M27	39,7	230	250	16	1 1/8"-7 UNC
		26	60	-	8	M24	32	70	-	8	M27					
500	127	28	210	230	20	M24	34	230	260	20	M30	46,0	250	280	20	1 1/8"-7 UNC
600	154	28	240	270	20	M27	36	260	290	20	M33	47,6	280	310	20	1 1/4"-7 UNC

*Observera: När det gäller DN 450 måste vridspjällsventilen fästas i flänsen med 8 gängskruvar. Övriga 16 flänshål kan förbindas med genomgående skruvar eller pinnbultar.

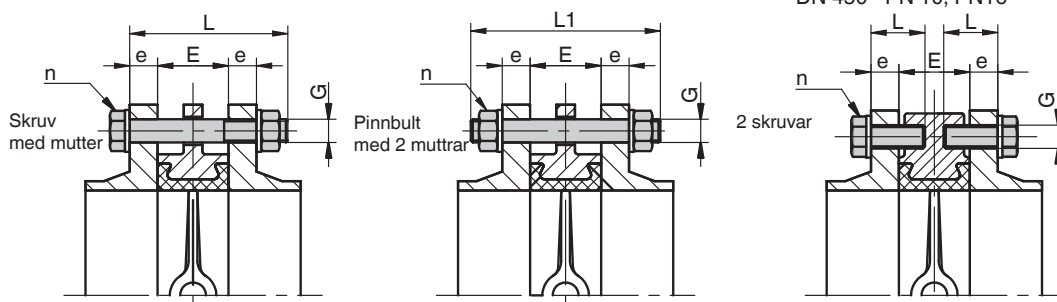

Ventilstyp lug (kod L)

DN	E	PN 10				PN 16				ASME B16.5 cl. 150			
		e	L	n	G	e	L	n	G	e	L	n	G
50	43	18	35	8	M16	18	35	8	M16	19,0	35	8	5/8"-11 UNC
65	46	18	40	8	M16	18	40	8	M16	22,2	45	8	5/8"-11 UNC
80	46	20	40	16	M16	20	40	16	M16	23,8	45	8	5/8"-11 UNC
100	52	20	45	16	M16	20	45	16	M16	23,8	45	16	5/8"-11 UNC
125	56	22	50	16	M16	22	50	16	M16	23,8	50	16	3/4"-10 UNC
150	56	22	50	16	M20	22	50	16	M20	25,4	50	16	3/4"-10 UNC
200	60	24	50	16	M20	24	50	24	M20	28,6	55	16	3/4"-10 UNC
250	68	26	60	24	M20	26	60	24	M24	30,2	60	24	7/8"- 9 UNC
300	78	26	65	24	M20	28	65	24	M24	31,7	70	24	7/8"- 9 UNC
350	78	26	65	32	M20	30	65	32	M24	34,9	70	24	1"- 8 UNC
400	102	26	75	32	M24	32	80	32	M27	36,5	85	32	1"- 8 UNC

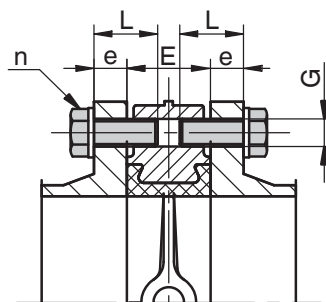

n = antal skruvar

Ventilhus typ U-sektion (kod U)

DN	E	PN 10					PN 16					ASME B16.5 cl. 150				
		e	L	L1	n	G	e	L	L1	n	G	e	L	L1	n	G
400	102	26	180	210	12	M24	32	200	220	12	M27	36,5	210	230	12	1"-8 UNC
			50					55								
450	114	26	190	220	16	M24	32	210	240	16	M27	39,7	230	250	16	1 1/8"-7 UNC
			50					55					8			
500	127	28	210	230	16	M24	34	230	260	16	M30	46,0	250	280	16	1 1/8"-7 UNC
			50					60					8			
600	154	28	240	270	16	M27	36	260	290	16	M33	47,6	280	310	16	1 1/4"-7 UNC
			50					60					8			

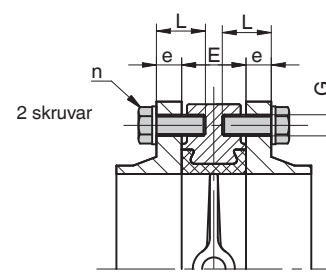
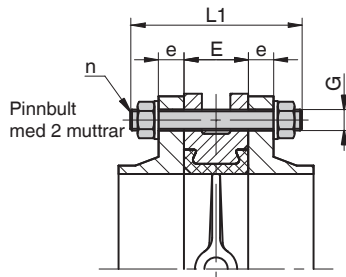
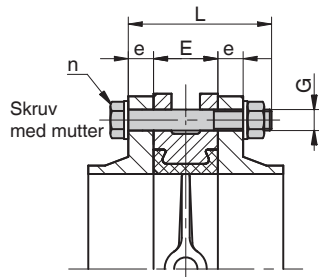

DN 450 - PN 10, PN 16

Mått gängade hål [mm]

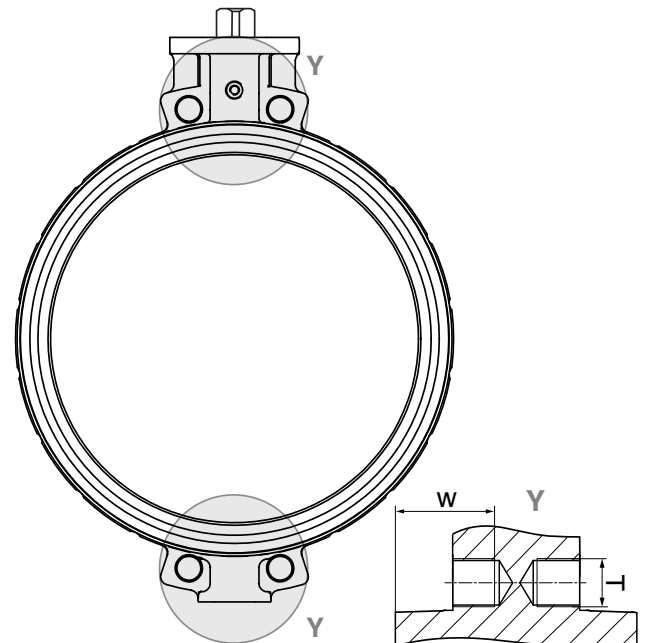
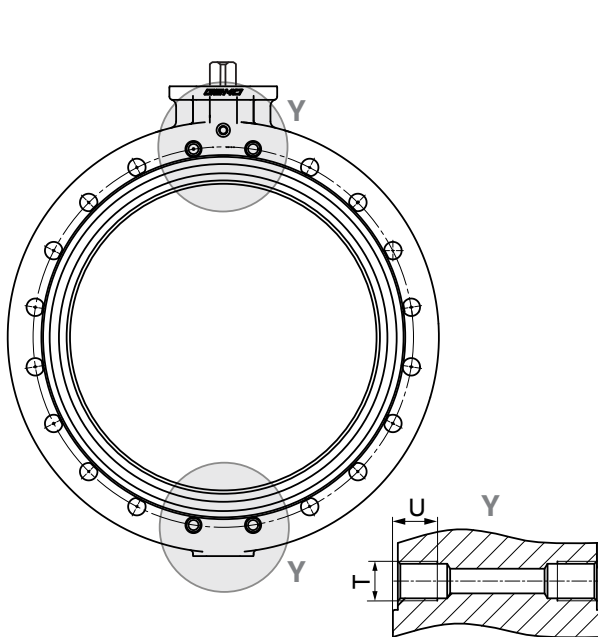

Hål flänsanslutning - U-sektion

DN	DIN EN 1092-2 PN 10		DIN EN 1092-2 PN 16		ASME B16.5 cl. 150	
	T	U	T	U	T	U
400	M24	24	M27	27	1"-8 UNC	-
450	M24	24	M27	27	1 1/8"-7 UNC	30
500	M24	24	M30	30	1 1/8"-7 UNC	30
600	M27	27	M33	33	1 1/4"-7 UNC	33

Hål flänsanslutning - wafer

DN	DIN EN 1092-2 PN 10		DIN EN 1092-2 PN 16		ASME B16.5 cl. 150	
	T	W	T	W	T	W
450	M24	46	M27	46	Ø 31,7	-

Anslutningsfläns, ventilhustyp wafer (kod W)

DN	PN 10				PN 16				ASME B16.5 cl. 150			
	K	n	G	w	K	n	G	w	K	n	G	w
25	85	4	M12	90°	85	4	M12	90°	79,4	4	1/2"	90°
32	100	4	M16	90°	100	4	M16	90°	88,9	4	1/2"	90°
40	110	4	M16	90°	110	4	M16	90°	98,4	4	1/2"	90°
50	125	4	M16	90°	125	4	M16	90°	120,6	4	5/8"	90°
65	145	4*	M16	90°	145	4*	M16	90°	139,7	4	5/8"	90°
80	160	8	M16	45°	160	8	M16	45°	152,4	4	5/8"	90°
100	180	8	M16	45°	180	8	M16	45°	190,5	8	5/8"	45°
125	210	8	M16	45°	210	8	M16	45°	215,9	8	3/4"	45°
150	240	8	M20	45°	240	8	M20	45°	241,3	8	3/4"	45°
200	295	8	M20	45°	295	12	M20	30°	298,5	8	3/4"	45°
250	350	12	M20	30°	355	12	M24	30°	362	12	7/8"	30°
300	400	12	M20	30°	410	12	M24	30°	431,8	12	7/8"	30°
350	460	16	M20	22°	470	16	M24	22,5°	476,3	12	1"	30°
400	515	16	M24	22,5°	525	16	M27	22,5°	539,8	16	1"	22,5°
450	565	20	M24	18°	585	20	M27	18°	577,9	16	1 1/8"	22,5°
500	620	20	M24	18°	650	20	M30	18°	635	20	1 1/8"	18°
600	725	20	M27	18°	770	20	M33	18°	749,3	20	1 1/4"	18°

* avviker från standarden
n = antal skruvar

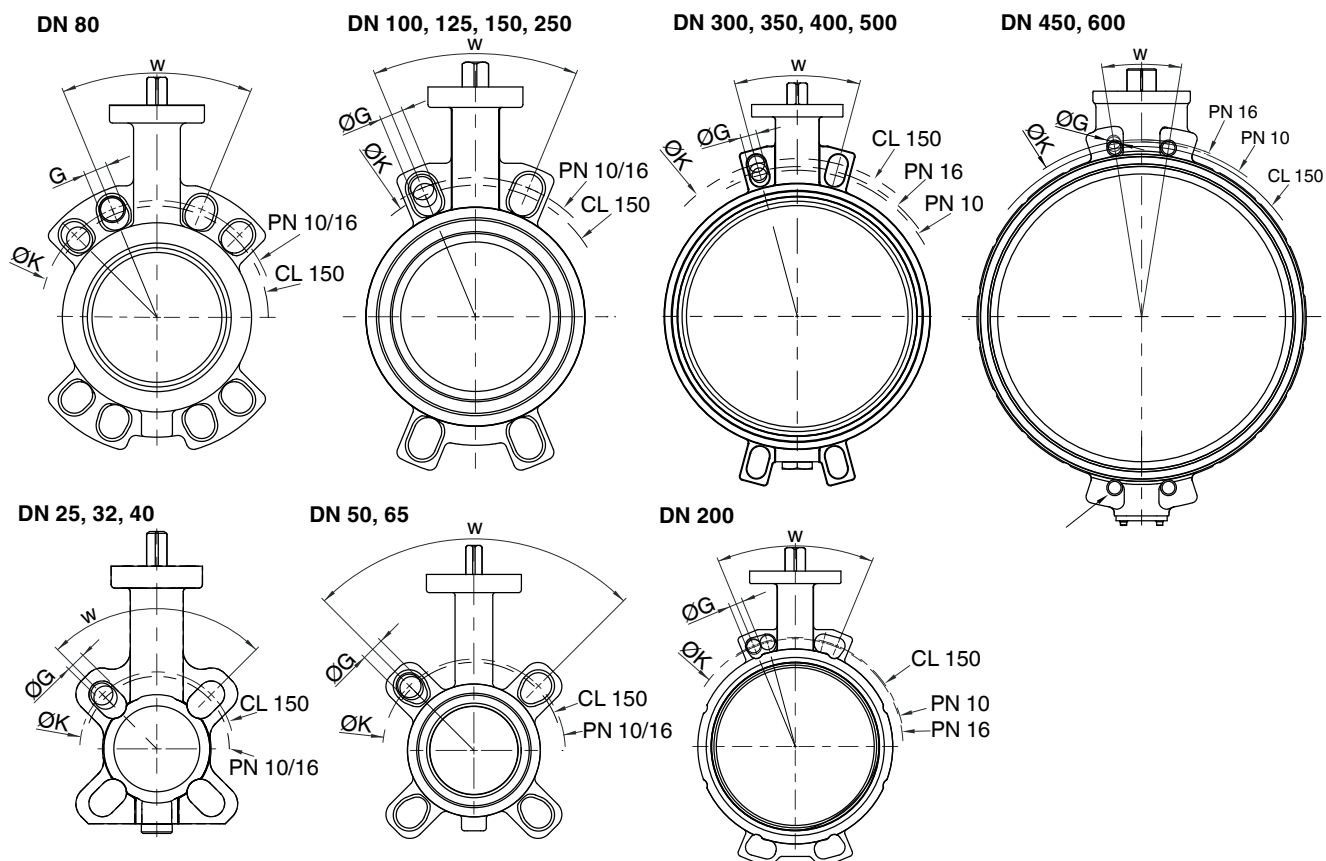

Tillgänglighet/Kod – ventilhustyp/Anslutningstyp

Wafer (Kod)																		
Flansch	20	25	32	40	50	65	80	100	125	150	200	250	300	350	400	450	500	600
DIN EN1092 PN06	3	3	3	3	3	3	3	3	3	3	3	3	3	-	-	-	-	-
DIN EN1092 PN10	3	3	3	3	3	3	3	3	3*	3	3	3*	3*	3	3	2	3	2
DIN EN1092 PN16	3	3	3	3	3	3	3	3	3*	3	3	3	3*	3	3	3	3	3
ASME B16.5 cl.150	D	D	D	D	D	D	D	D	D	D	D	D	D	D	D	D	D	D
AS 2129 D	T	T	T	T	T	-	-	T*	T*	T*	T*	-	T*	T	-	-	-	T
AS 2129 E	U	U	U	U	U	-	-	U	U*	U	U*	U*	U*	U	-	U	-	U
JIS 5 K	K	K	K	K	K	K	K	K	K	K	-	K	-	-	-	-	-	-
JIS 10 K	G	G	G	G	G	G	G	G	G	G	G	-	-	-	G	G	G	G
BS 10 D	H	H	H	H	H	-	-	-	H	-	-	-	-	H	-	-	-	H
BS 10 E	S	S	S	S	S	-	-	S	S	S	S	-	-	S	-	S	-	S

* **Observera:** Vid monteringen måste vridspjällsventilen centreras

Lug (Kod)												
Flansch	50	65	80	100	125	150	200	250	300	350	400	
DIN EN1092 PN06	1	1	1	1	1	1	1	1	1	-	-	
DIN EN1092 PN10	3	3*	3	3	3	3	2	2	2	2	2	
DIN EN1092 PN16	3	3*	3	3	3	3	3	3	3	3	3	
ASME B16.5 cl.150	D	D	D	D	D	D	D	D	D	D	D	
AS 2129 D	T	-	T	T	T	T	T	-	T	-	-	
AS 2129 E	U	-	U	U	U	U	U	U	U	-	-	
JIS 10 K	G	G	G	G	G	G	G	G	-	G	G	
BS 10 D	H	-	H	H	H	H	H	-	H	-	-	
BS 10 E	S	-	S	S	S	S	S	S	S	-	-	

* borrat, med 4 gängade hål

U-Sektion (Kod)				
Flansch	400	450	500	600
DIN EN1092-2 PN06	1*	1*	1*	1*
DIN EN1092-2 PN10	2	2	2	2
DIN EN1092-2 PN16	3	3	3	3
ASME B16.5 cl.150	D	D	D	D
AS 2129 E	-	U	-	-
BS 10 D	-	-	-	H
BS 10 E	-	S	-	-

* finns endast med gängade hål

Sektionsritning

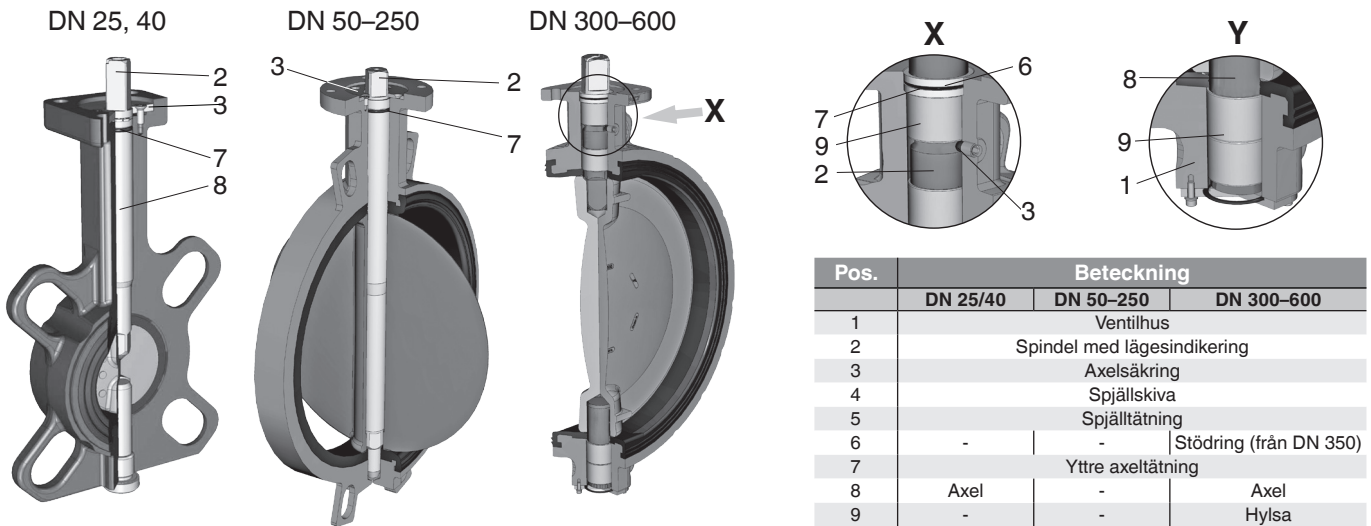

12 beställningsuppgifter/anslutningsmått – GEMÜ 480 vridspjällsventil med fri axelände [mm]

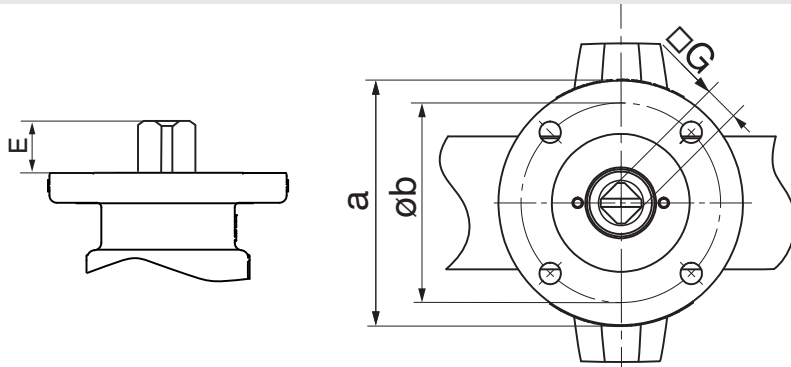

12 Manöverdonets fläns

DN	ISO	Øb	Wellenende	□G		E		Kod
				PS10 / PS16	PS3	PS10 / PS16	PS3	
25	F05	50	D	9	-	19	-	05 D09
40	F05	50	D	9	-	19	-	05 D09
50	F05	50	D	9	-	19	-	05 D09
65	F05	50	D	11	-	19	-	05 D11
80	F05	50	D	11	-	19	-	05 D11
100	F05	50	D	14	-	19	-	05 D14
125	F07	70	D	17	-	25	-	07 D17
150	F07	70	D	17	-	25	-	07 D17
200	F10	102	D	22	17	32	25	10 D22
250	F10	102	D	22	17	32	25	10 D22
300	F10	102	D	22	17	32	25	10 D22
350	F12	125	D	27	22	28	28	12 D27
400	F14	140	D	36	27	37	28	14 D36
450	F14	140	D	36	27	37	28	14 D36
500	F14	140	D	36	27	37	28	14 D36
600	F16	165	D	46	36	47	37	16 D46

Beställningsexempel	1	2	3	4	5	6	7	8	9	10	11	12	13
Kod	480	Beställningsuppgifter vridspjällsventil									F	07 D17	

(sidan 4)

12 Beställningsuppgifter/mått – GEMÜ 487 vridspjällsventil med manuell manöverdon [mm]

Handspak

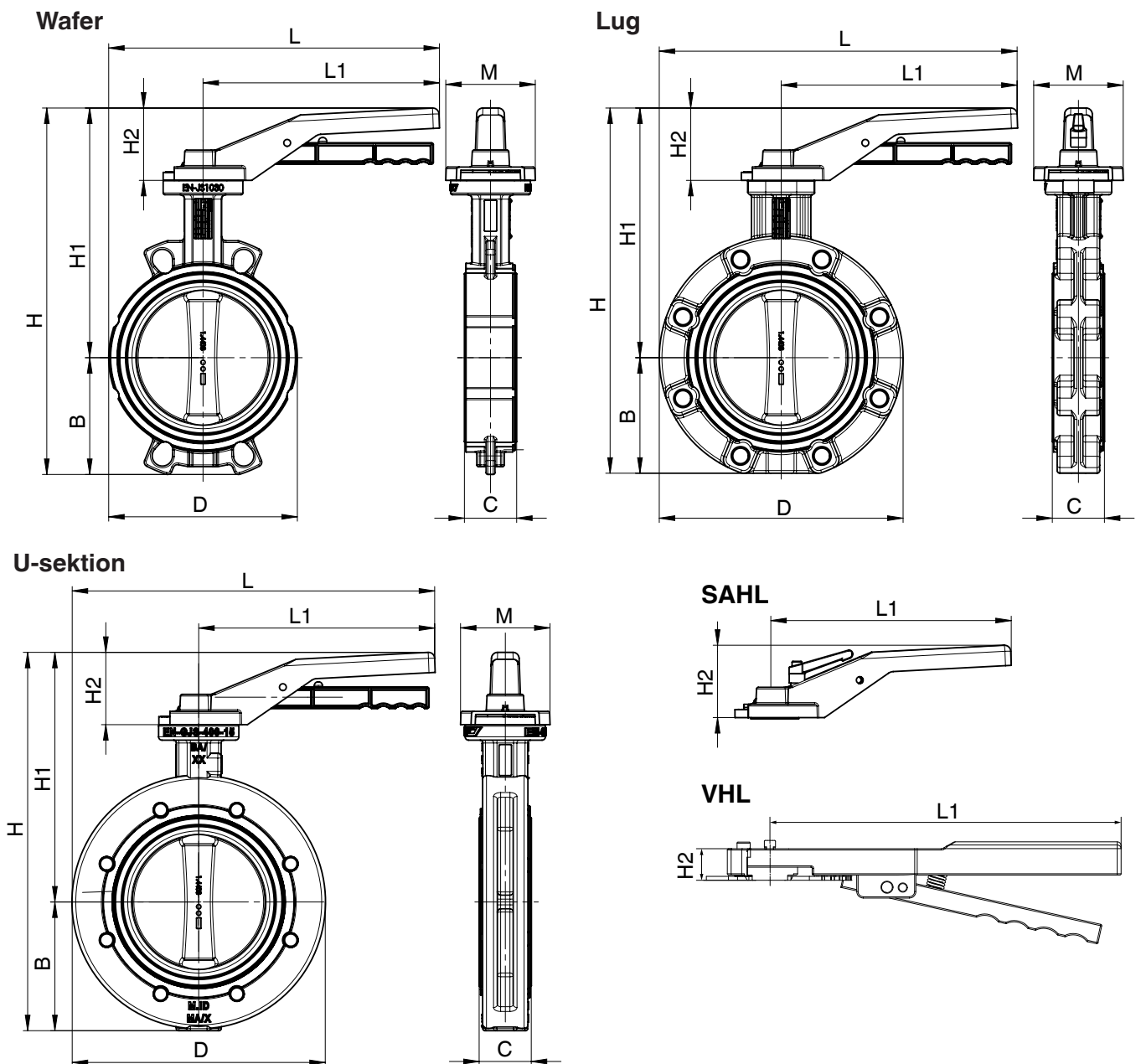

DN	PS	Vikt [kg]	Huvudfläns	Handspak med steg		Steglös handspak		
				Beteckning	Kod	Beteckning	Kod	
25, 40, 50	10, 16	0,314	F05	AHL09.F05.200	AHL09	SAHL09.F05.200	SAHL09	
25 - 100*		0,686	F05	VHL F0514.195	VHL14	-	-	
65 - 80		0,314	F05	AHL11.F05.200	AHL11	SAHL11.F05.200	SAHL11	
80 - 150		1,200	F07	VHL F0717.267	VHL17	-	-	
100		0,314	F05	AHL14.F05.200	AHL14	SAHL14.F05.200	SAHL14	
125 - 150		0,716	F07	AHL17.F07.270	AHL17	SAHL17.F07.270	SAHL17	
200**		0,730	F10	AHL22.F10.340	AHL22	-	-	
		2,073	F10	VHL F1022.330	VHL22	-	-	
250*		3	0,730	F10	AHL17.F10.340	AHL22	-	-

Material: AHL, SAHL: Aluminium/VHL: Rostfritt stål

* DN 80, 100 inte för LUG-ventilhus

**För manuell manövrering rekommenderar vi en drivenhet vid dessa nominella diametrar.

12 Beställningsuppgifter/mått – GEMÜ 487 vridspjällsventil med manuell manöverdon [mm]

Handspak

Ventilhustyp													Handspak					
DN	Wafer						Lug						AHL / SAHL / VHL					
	D	L	B	H1	H	kg	D	L	B	H1	H	kg	C	PS	H2	L1	M	Kod
25	59,5	229,8	41,3	170	211,3	1,5	-	-	-	-	-	-	25	16	70	200 195	74 107	AHL09 / SAHL09 VHL14
40	75,5	237,8	53,8	190	243,8	1,8	-	-	-	-	-	-	33	16	70	200 195	74 107	AHL09 / SAHL09 VHL14
50	91,0	245,5	60,2	190	250,2	3,3	151,0	275,5	60,0	190	250,0	4,0	43	16	70	200 195	74 107	AHL09 / SAHL09 VHL14
65	111,0	255,5	67,6	210	277,6	3,9	171,0	285,5	67,0	210	277,0	4,3	46	16	70	200 195	74 107	AHL11 / SAHL11 VHL14
80	130,0	265,0	90,4	215	305,4	4,3	188,0	294,0	89,0	215	304,0	7,3	46	16	70	200 195	74 107	AHL11 / SAHL11 VHL14
							188,0	294,0	89,0	215	304,0	7,3	46			267	107	VHL17
100	150,0	275,0	105,1	236	341,1	5,8	218,5	309,3	103,0	236	339,0	7,8	52	16	70	200 195	74 107	AHL14 / SAHL14 VHL14
							218,5	309,3	103,0	236	339,0	7,8	52			267	107	VHL17
125	179,0	359,5	119,6	277	396,6	8,2	250,0	395,0	119,0	277	396,0	11,7	56	16	90	270 267	102 107	AHL17 / SAHL17 VHL17
150	210,0	375,0	131,5	290	421,5	9,3	275,0	407,5	130,5	290	420,5	14,7	56	16	90	270 267	102 107	AHL17 / SAHL17 VHL17
200	264,0	472,0	160,0	580	740,0	13,4	330,0	505,0	170,5	580	750,5	21,7	60	16	340	340 330	126 191	AHL22 / SAHL22 VHL22
250	314,0	497,0	195,3	605	800,3	22,9	402,0	541,0	203,0	605	808,0	32,7	68	3	340	340	126	AHL22 / SAHL22

Beställningsexempel	1	2	3	4	5	6	7	8	9	10	11	12	
Kod	487	Beställningsuppgifter vridspjällsven- til (sidan 4)										0	AHL09

12 Beställningsuppgifter/mått – GEMÜ 487 vridspjällsventil med manuellt manöverdon [mm]

Drivenhet med handvred

Wafer

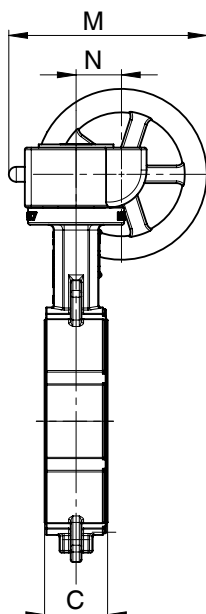
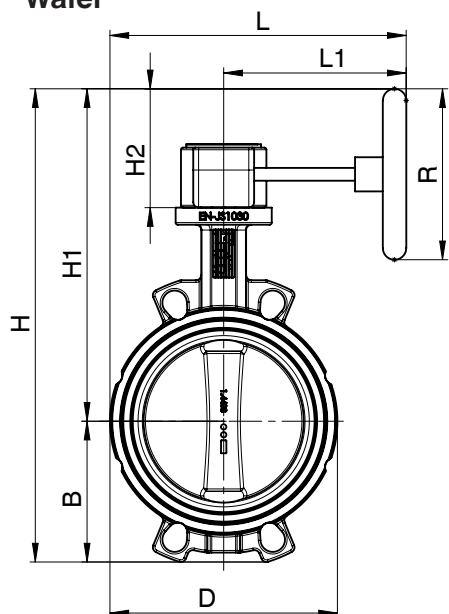

Lug

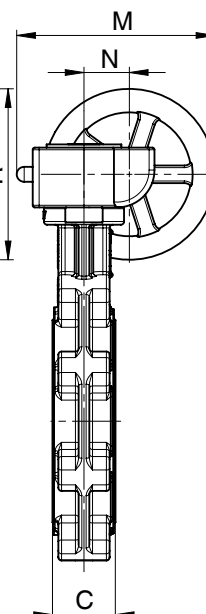
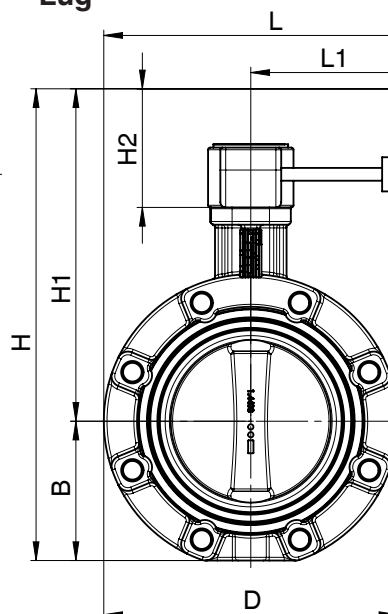

U-sektion

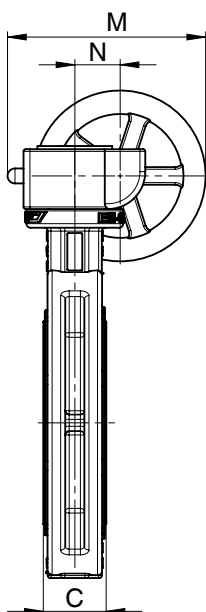
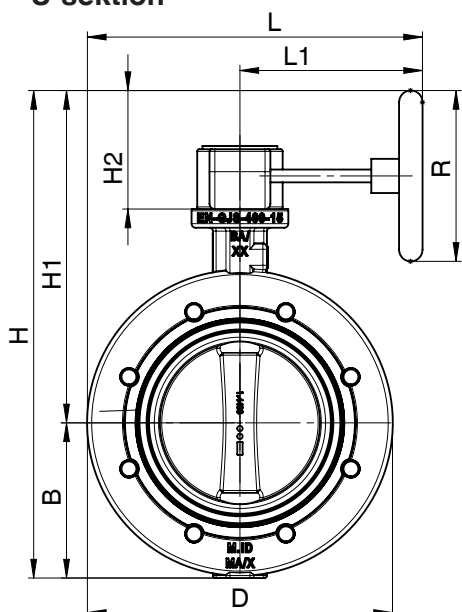

DN	Vikt [kg]	Beteckning	Material	Kod
25, 40, 50	0,8	GB23205F05-F07D9 PS100	Aluminium, polyuretanbeläggning	GB232
65 - 80	0,8	GB23205F05-F07D11 PS100		GB232
100	0,8	GB23205F05-F07D14 PS100		GB232
125	0,9	GB23206F05-F07D17 PS100		GB232
150	0,9	GB23206F05-F07D17 PS160		GB232
200 - 300	1,4	GB23208F07-F10D22 PS200		GB232
350	4,7	GB23214F10-F12D27 SG500		GB232
400	4,7	GB23214 F14D36 SG500		GB232
450 - 500	14,0	GB880NF10-F14D36 SG800	GG25, polyuretanbeläggning	GB880N
600	22,0	GB1250NF12-F16D46 SG700		GB1250N

12 Beställningsuppgifter/mått – GEMÜ 487 vridspjällsventil med manuell manöverdon [mm]

Drivenhet med handvred

Ventilhustyp								Manöverdon					
Wafer								GB					
DN	D	L	B	C	H1	H	kg	H2	L1	R	N	M	Kod
25	59,5	229,8	41,3	25	190,0	231,3	2,0	90,0	121	100	42,5	155,5	GB232
40	75,5	237,8	53,8	33	210,0	263,8	2,3	90,0	121	100	42,5	155,5	GB232
50	91	245,5	60,2	43	210,0	270,2	3,8	90,0	121	100	42,5	155,5	GB232
65	111	255,5	67,6	46	230,0	297,6	4,4	90,0	121	100	42,5	155,5	GB232
80	130	265,0	90,4	46	235,0	325,4	4,8	90,0	121	100	42,5	155,5	GB232
100	150	275,0	105,1	52	256,0	361,1	6,3	90,0	121	100	42,5	155,5	GB232
125	179	359,5	119,6	56	277,0	396,6	8,4	90,0	171	100	42,5	155,5	GB232
150	210	375,0	131,5	56	320,0	451,5	9,5	120,0	171	160	42,5	185,5	GB232
200	264	472,0	160,0	60	390,0	550,0	14,1	150,0	195	200	50,0	221,0	GB232
250	314	497,0	195,3	68	415,0	610,3	23,6	150,0	195	200	50,0	221,0	GB232
300	364	522,0	236,3	78	440,0	676,3	32,2	150,0	195	200	50,0	221,0	GB232
350	440	220,0	266,0	78	658,5	924,5	52,7	337,5	293	500	80,0	428,0	GB232
400	485	242,5	308,0	102	684,5	992,5	76,7	337,5	376	500	80,0	428,0	GB232
450	541	270,5	333,0	114	872,0	1205,0	109,0	500,0	465	800	86,0	486,0	GB880N
500	600	300,0	358,0	127	898,0	1256,0	134,0	500,0	465	800	86,0	486,0	GB880N
600	700	350,0	442,0	154	930,0	1372,0	214,0	410,0	480	700	105,0	486,0	GB1250N
Lug								GB					
DN	D	L	B	C	H1	H	kg	H2	L1	R	N	M	Kod
50	151,0	196,5	60,0	43	210,0	270,0	4,5	90,0	121	100	42,5	155,5	GB232
65	171,0	206,5	67,0	46	230,0	297,0	4,8	90,0	121	100	42,5	155,5	GB232
80	188,0	215,0	89,0	46	235,0	324,0	7,8	90,0	121	100	42,5	155,5	GB232
100	218,5	230,3	103,0	52	256,0	359,0	8,3	90,0	121	100	42,5	155,5	GB232
125	250,0	296,0	119,0	56	277,0	396,0	11,9	90,0	171	100	42,5	155,5	GB232
150	275,0	308,5	130,5	56	320,0	450,5	14,9	120,0	171	160	42,5	185,5	GB232
200	330,0	360,0	170,5	60	390,0	560,5	22,4	150,0	195	200	50,0	221	GB232
250	402,0	396,0	203,0	68	415,0	618,0	33,4	150,0	195	200	50,0	221	GB232
300	472,0	431,0	236,0	78	440,0	676,0	44,4	150,0	195	200	50,0	221	GB232
350	520,0	553,0	260,0	78	658,5	918,5	70,7	337,5	293	500	80,0	428	GB232
400	596,0	674,0	300,0	102	684,5	984,5	114,7	337,5	376	500	80,0	428	GB232
U-Section								GB					
DN	D	L	B	C	H1	H	kg	H2	L1	R	N	M	Kod
400	485	530,0	237	102	684,5	921,5	111,7	337,5	376	500	80,0	428,0	GB232
450	541	631,5	237	114	872,0	1109,0	139,0	500,0	465	800	86,0	486,0	GB880N
500	715	644,0	237	127	898,0	1135,0	178,0	500,0	465	800	86,0	486,0	GB880N
600	840	701,0	237	154	930,0	1167,0	283,0	410,0	480	700	105,0	486,0	GB1250N

Beställningsexempel	1	2	3	4	5	6	7	8	9	10	11	12
Kod	487	Beställningsuppgifter vridspjällsven- til (sidan 4)									0	GB232

Tekniska data – GEMÜ 481 med pneumatiskt manöverdon typ ADA/ASR



Styrmedium

Filtrerad, torr tryckluft, inget korrosivt medium

Temperaturområde

-30 till +100°C, andra temperaturer på begäran

Styrtryck

6–8 bar

Vridvinkel

±5° inställningsbar (85°–95°)

90°

12 Beställningsuppgifter – GEMÜ 481 med pneumatiskt manöverdon typ ADA/ASR

12 Manöverdonsstorlek*

Driftryck 16 bar (se beställningsuppgifter – driftryck kod 3)

DN	Pneumatiskt dubbelverkande	Kod	Pneumatiskt enkelverkande	Kod
25	ADA0020U F05 Y S14/S11A	BU02AB0	ASR0020U S08 F03F05Y S09A	AU02FN0
40	ADA0020U F05 Y S14/S11A	BU02AB0	ASR0020U S08 F03F05 Y S09A	AU02FN0
50	ADA0020U F05 Y S14/S11A	BU02AB0	ASR0020U S08 F03F05 Y S09A	AU02FN0
65	ADA0020U F05 Y S14/S11A	BU02AB0	ASR0040U S14 F05 Y S14/S11A	AU04KB0
80	ADA0040U F05 Y S14/S11A	BU04AB0	ASR0080U S14 F05F07 Y S17/S14A	AU08KC0
100	ADA0080U F05F07 Y S17/S14A	BU08AC0	ASR0200U S14 F07F10 Y S17/S14A	AU20KE0
125	ADA0080U F05F07 Y S17/S14A	BU08AC0	ASR0200U S14 F07F10 Y S17/S14A	AU20KE0
150	ADA0130U F05F07 Y S17/S14A	BU13AC0	ASR0300U S14 F07F10 Y S22A	AU30KD0
200	ADA0300U F07F10 Y S22A	BU30AD0	ASR0850U S14 F10F12 Y S27A	AU85KG0

Driftryck 10 bar (se beställningsuppgifter – driftryck kod 2)

250	ADA0500U F10 Y S22A	BU50AF0	ASR1200U S14 F10F14 Y S36A	A12UKH0
300	ADA0500U F10 Y S22A	BU50AF0	ASR1200U S14 F10F14 Y S36A	A12UKH0
350	ADA0850U F10F12 Y S27A	BU85AG0	ASR1750U S14 F14 Y S36A	A17UKK0
400	ADA1200U F10F14 Y S36A	B12UAH0	ASR2500U S14 F14 Y S36A	A25UKK0
450	ADA1750U F14 Y S36 A	B17UAK0	ASR2500U S14 F14 Y S36A	A25UKK0
500	ADA1750U F14 Y S36 A	B17UAK0	ASR4000U S14 F16F25 Y S55A	A40UKM0
600	ADA2100U F16 Y S46A	B21UAL0		

Driftryck 3 bar (se beställningsuppgifter – driftryck kod 0)

200	ADA0200U F07F10 Y S17/S14A	BU20AE0	ASR0500U S14 F10 Y S22A	AU50KF0
250	ADA0200U F07F10 Y S17/S14A	BU20AE0	ASR0500U S14 F10 Y S22A	AU50KF0
300	ADA0300U F07F10 Y S22A	BU30AD0	ASR0850U S14 F10F12 Y S27A	AU85KG0
350	ADA0300U F07F10 Y S22A	BU30AD0	ASR0850U S14 F10F12 Y S27A	AU85KG0
400	ADA1200U F10F14 Y S36A	B12UAH0	ASR1750U S14 F14 Y S36A	A17UKK0
450	ADA1200U F10F14 Y S36A	B12UAH0	ASR1750U S14 F14 Y S36A	A17UKK0
500	ADA1200U F10F14 Y S36A	B12UAH0	ASR2100U S14 F14 Y S36A	A21UKK0
600	ADA2100U F16 Y S46A	B21UAL0	ASR4000U S14 F16F25 Y S55A	A40UKM0

* Dimensionering för vätskor +20 till +80°C vid styrtryck 6 bar

Beställningsexempel	1	2	3	4	5	6	7	8	9	10	11	12
Kod	481	Beställningsuppgifter vridspjällsventil										BU13AC0

Slaglängdsbegränsning på begäran

(sidan 4)

Mått, manöverdon ADA/ASR [mm]

ADA/ASR 0020U-0850U

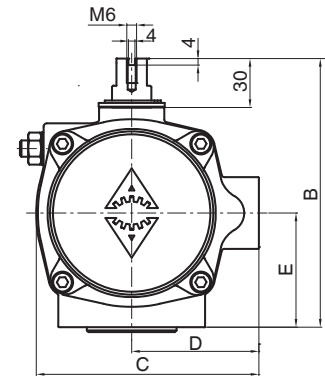
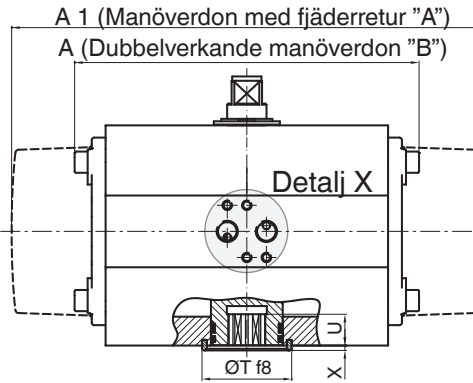
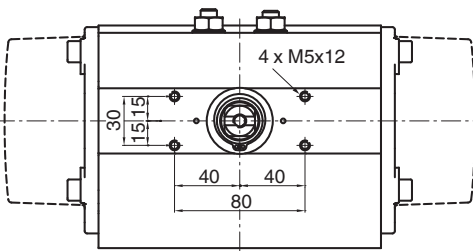

ADA/ASR 1200U-4000U

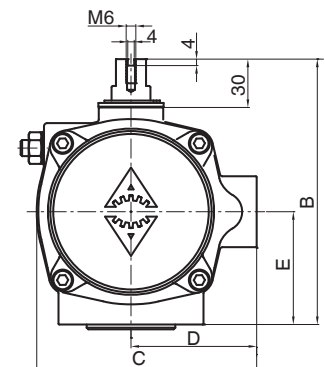
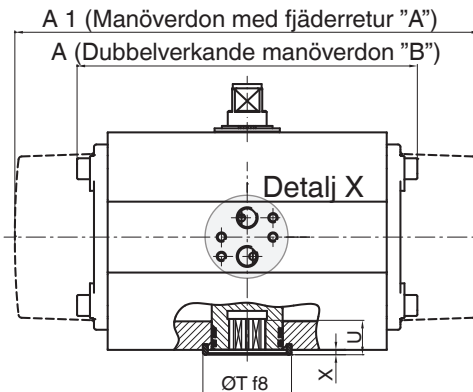
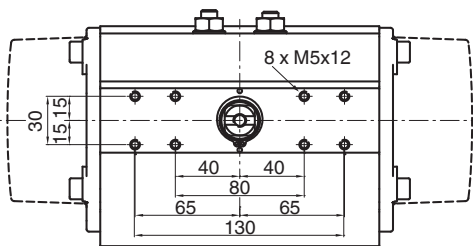

Detalj X ADA/ASR 0020U-1750U

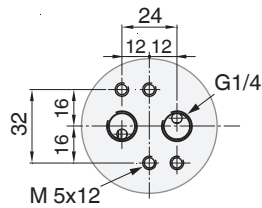

Detalj X ADA/ASR 2100U-4000U

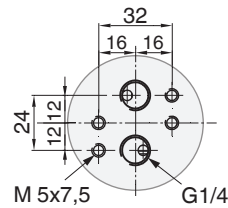

ADA/ASR	0020U		0040U		0080U	0130U	0200U	0300U	0500U	0850U	1200U	1750U	2100U	2500U	4000U	
ISO 5211	F03/ F05	F04	F05	F04	F05	F05	F05	F07	F07	F10	F10	F10	F14	F16	F16	F16
Åttkant	9	14		14	17	17	17	22	22	27	36	36	46	46	55	
Luft- anslutning	G1/4		G1/4		G1/4	G1/4	G1/4	G1/4	G1/4	G1/4	G1/4	G1/4	G1/4	G1/4	G1/4	
A	145		158		177	196	225	273	304	372	439	461	510	518	630	
A1	163		195		217	258	299	348,5	397	473	560	601	702	738	940	
B	96		115		137	147	165	182	199	221	249	280	313	383	434	
C	76		91		111	122	135,5	152,5	173	191,5	212,5	242,5	276,5	356	415	
D	48		56		66	71	78	86	96	106	116	131	148	177,5	213	
E	34		45		55	60	70	80	85	98	114	130	147	176,5	201	
ØT	25	35		35	55	55	55	70	70	85	100	100	130	130	200	
U	10	12		12	19	22	23	24	32	39	48	50	50	58	60	
Vikt [kg]																
ADA	1,4		2,1		3,0	3,8	5,6	8,5	11,2	16,9	25,8	32,5	49,0	69,6	129,4	
ASR	1,5		2,3		3,7	4,8	7,3	10,8	15,4	22,2	34,3	46,0	68,0	99,9	182,9	

Mått – GEMÜ 481 vridspjällsventil med pneumatiskt manöverdon
GEMÜ ADA – dubbelverkande [mm]

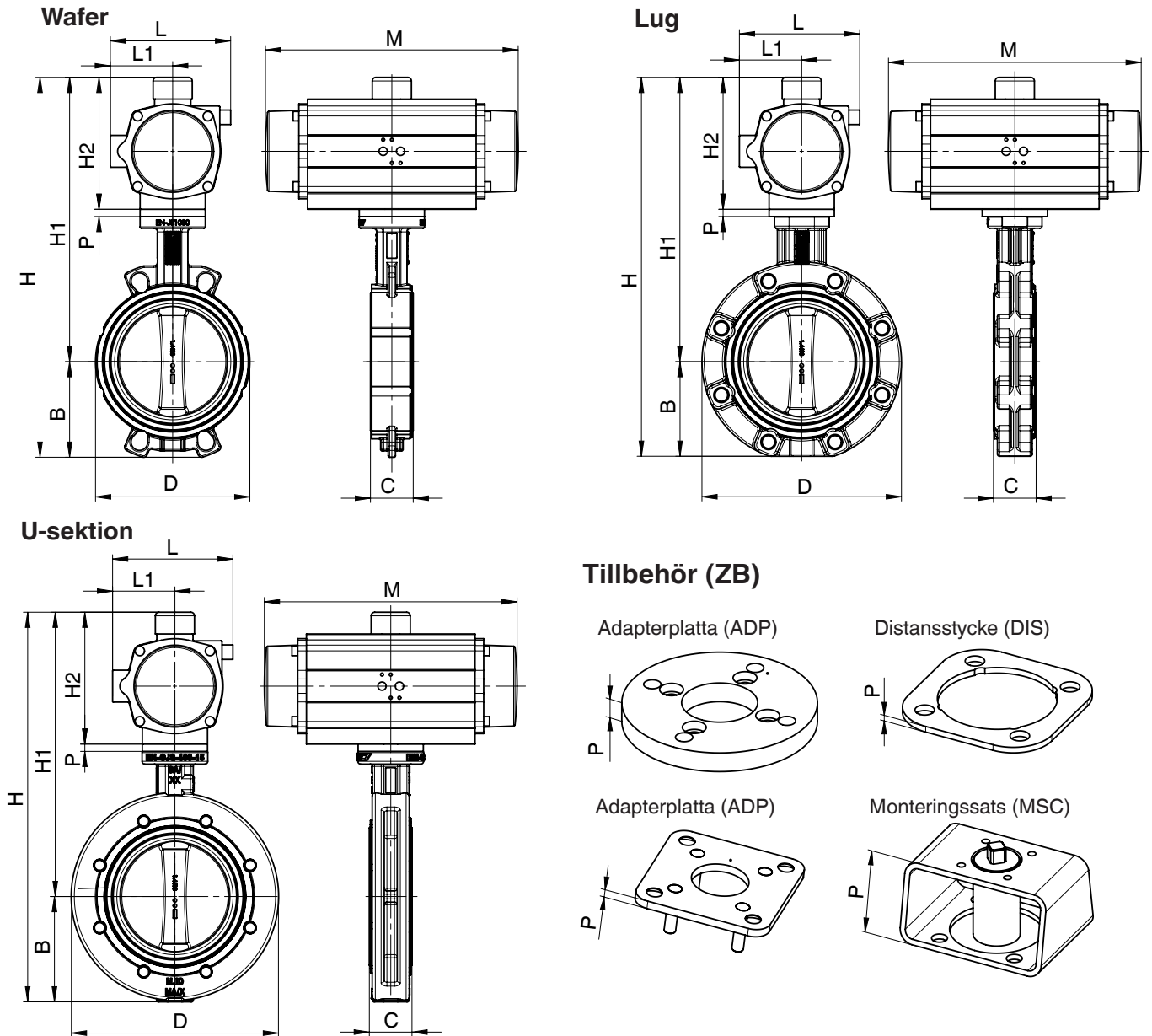

**Mått – GEMÜ 481 vridspjällsventil med pneumatiskt manöverdon
GEMÜ ADA – dubbelverkande [mm]**

Ventilhustyp								Manöverdon						
Wafer								ADA						
DN	PS	D	B	C	H1	H	kg	H2	L1	L	M	ZB	P	Kod
25	16	59,5	41,3	25	196	237,3	2,6	96	48	76,0	145	-	0	BU02AB0
40	16	75,5	53,8	33	216	269,8	2,9	96	48	76,0	145	-	0	BU02AB0
50	16	91	60,2	43	216	276,2	4,4	96	48	76,0	145	-	0	BU02AB0
65	16	111	67,6	46	236	303,6	5	96	48	76,0	145	-	0	BU02AB0
80	16	130	90,4	46	260	350,4	6,1	115	56	91,0	158	-	0	BU04AB0
100	16	150	105,1	52	303	408,1	8,5	137	66	111,0	177	-	0	BU08AC0
125	16	179	119,6	56	324	443,6	10,5	137	66	111,0	177	-	0	BU08AC0
150	16	210	131,5	56	347	478,5	12,4	147	71	122,0	196	-	0	BU13AC0
200	16	264	160,0	60	432	592	21,2	182	86	152,5	273	DIS	10	BU30AD0
250	10	314	195,3	68	464	659,3	33,4	199	96	173,0	304	-	0	BU50AF0
300	10	364	236,3	78	489	725,3	42	199	96	173,0	304	-	0	BU50AF0
350	10	440	266	78	542	808	64,9	221	106	191,5	372	-	0	BU85AG0
400	10	485	308	102	596	904	97,8	249	116	212,5	439	-	0	B12UAH0
450	10	541	333	114	652	985	127,5	280	131	242,5	461	-	0	B17UAK0
500	10	600	358	127	678	1036	152,5	280	131	242,5	461	-	0	B17UAK0
600	10	700	442	154	783	1225	241	313	148	276,5	510	-	0	B21UAL0
200	3	264	160	60	405	565	18,3	165	78	135,5	225	-	0	BU20AE0
250	3	314	195,3	68	430	625,3	27,8	165	78	135,5	225	-	0	BU20AE0
300	3	364	236,3	78	472	708,3	39,3	182	86	152,5	273	-	0	BU30AD0
350	3	440	266	78	518	784	56,5	182	86	152,5	273	ADP	15	BU30AD0
400	3	485	308	102	596	904	97,8	249	116	212,5	439	-	0	B12UAH0
450	3	541	333	114	621	954	120,8	249	116	212,5	439	-	0	B12UAH0
500	3	600	358	127	647	1005	145,8	249	116	212,5	439	-	0	B12UAH0
600	3	700	442	154	783	1225	241	313	148	276,5	510	-	0	B21UAL0
Lug								ADA						
DN	PS	D	B	C	H1	H	kg	H2	L1	L	M	ZB	P	Kod
50	16	151	60	43	216	276	5,1	96	48	76,0	145	-	0	BU02AB0
65	16	171	67	46	236	303	5,4	96	48	76,0	145	-	0	BU02AB0
80	16	188	89	46	260	349	9,1	115	56	91,0	158	-	0	BU04AB0
100	16	218,5	103	52	303	406	10,5	137	66	111,0	177	-	0	BU08AC0
125	16	250	119	56	324	443	14	137	66	111,0	177	-	0	BU08AC0
150	16	275	130,5	56	347	477,5	17,8	147	71	122,0	196	-	0	BU13AC0
200	16	330	170,5	60	432	602,5	29,5	182	86	152,5	273	DIS	10	BU30AD0
250	10	402	203	68	464	667	43,2	199	96	173,0	304	-	0	BU50AF0
300	10	472	236	78	489	725	54,2	199	96	173,0	304	-	0	BU50AF0
350	10	520	260	78	542	802	82,9	221	106	191,5	372	-	0	BU85AG0
400	10	596	300	102	596	896	135,8	249	116	212,5	439	-	0	B12UAH0
450	10	640	333	114	652	985	156,5	280	131	242,5	461	-	0	B17UAK0
500	10	710	358	127	678	1036	198,5	280	131	242,5	461	-	0	B17UAK0
600	10	840	442	154	783	1225	285	313	148	276,5	510	-	0	B21UAL0
200	3	330	170,5	60	405	575,5	26,6	165	78	135,5	225	-	0	BU20AE0
250	3	402	203	68	430	633	37,6	165	78	135,5	225	-	0	BU20AE0
300	3	472	236	78	472	708	51,5	182	86	152,5	273	-	0	BU30AD0
350	3	520	260	78	518	778	74,5	182	86	152,5	273	ADP	15	BU30AD0
400	3	596	300	102	596	896	135,8	249	116	212,5	439	-	0	B12UAH0
U-Sektion								ADA						
DN	PS	D	B	H1	H	kg	C	H2	L1	L	M	ZB	P	Kod
400	3	485	237	596	833	132,8	102	249	116	212,5	439	-	0	B12UAH0
450	3	541	237	621	858	150,8	114	249	116	212,5	439	-	0	B12UAH0
500	3	715	237	647	884	189,8	127	249	116	212,5	439	-	0	B12UAH0
600	3	840	237	783	1020	310	154	313	148	276,5	510	-	0	B21UAL0

Mått – GEMÜ 481 vridspjällsventil med pneumatiskt manöverdon
GEMÜ ASR – enkelverkande [mm]

Wafer

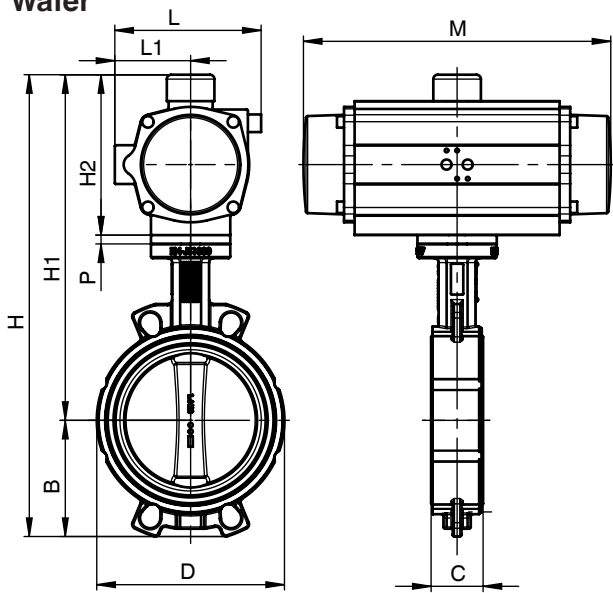

Lug

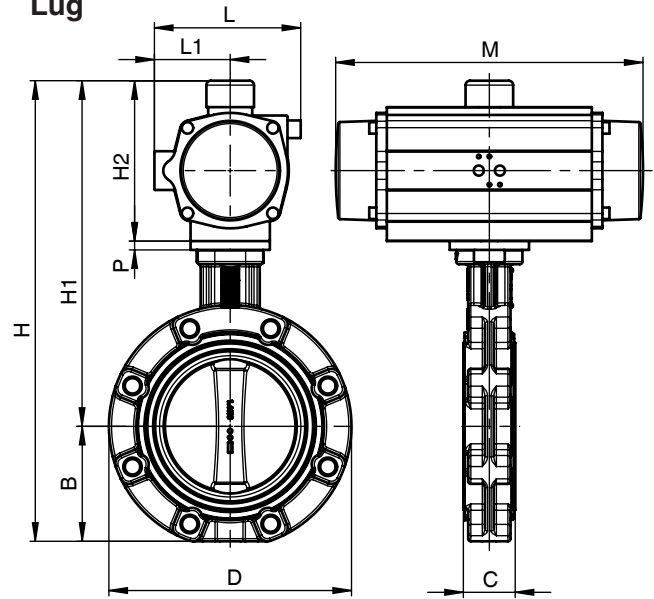

U-sektion

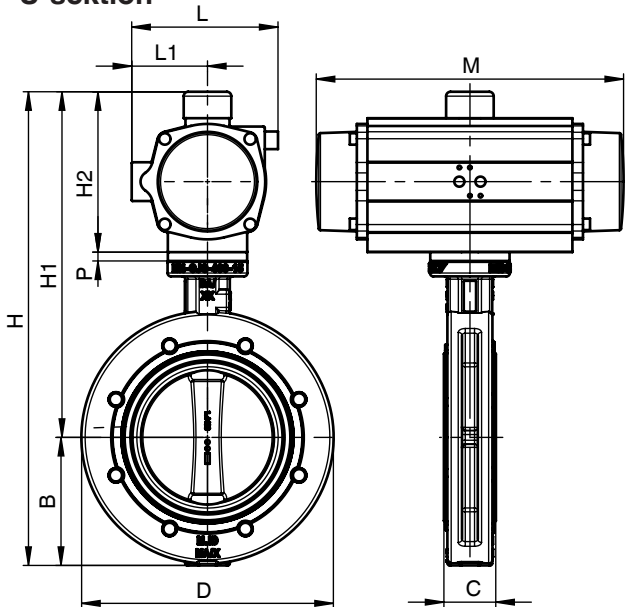

Tillbehör (ZB)

Adapterplatta (ADP)

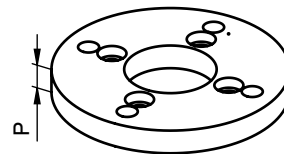

Distansstycke (DIS)

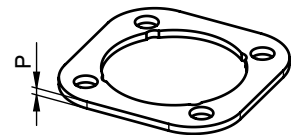

Adapterplatta (ADP)

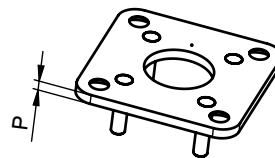

Monteringssats (MSC)

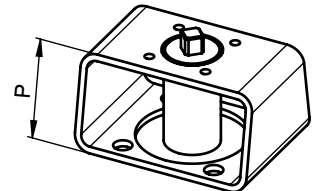

**Mått – GEMÜ 481 vridspjällsventil med pneumatiskt manöverdon
GEMÜ ASR – enkelverkande [mm]**

Tillbehör								Manöverdon						
Wafer								ASR						
DN	PS	D	B	C	H1	H	kg	H2	L1	L	M	ZB	P	Kod
25	16	59,5	41,3	25	196	237,3	2,7	96	48	76,0	163	-	0	AU02FN0
40	16	75,5	53,8	33	216	269,8	3	96	48	76,0	163	-	0	AU02FN0
50	16	91	60,2	43	216	276,2	4,5	96	48	76,0	163	-	0	AU02FN0
65	16	111	67,6	46	255	322,6	5,9	115	56	91,0	195	-	0	AU04KBO
80	16	130	90,4	46	282	372,4	7,7	137	66	111,0	217	-	0	AU08KCO
100	16	150	105,1	52	341	446,1	12,8	165	78	135,5	299	ADP	10	AU20KE0
125	16	179	119,6	56	352	471,6	14,8	165	78	135,5	299	-	0	AU20KE0
150	16	210	131,5	56	382	513,5	19,4	182	86	152,5	348,5	-	0	AU30KDO
200	16	264	160	60	461	621	34,9	221	106	191,5	473	-	0	AU85KGO
250	10	314	195,3	68	514	709,3	56,5	249	116	212,5	560	-	0	A12UKHO
300	10	364	236,3	78	539	775,3	65,1	249	116	212,5	560	-	0	A12UKHO
350	10	440	266	78	691	957	94	280	131	242,5	601	MSC	90	A17UKKO
400	10	485	308	102	730	1038	171,9	383	117,5	356,0	738	-	0	A25UKKO
450	10	541	333	114	755	1088	194,9	383	117,5	356,0	738	-	0	A25UKKO
500	10	600	358	127	861	1219	302,9	343	213	415,0	940	MSC	120	A40UKMO
200	3	264	160	60	439	599	28,1	199	96	173,0	397	-	0	AU50KFO
250	3	314	195,3	68	464	659,3	37,6	199	96	173,0	397	-	0	AU50KFO
300	3	364	236,3	78	511	747,3	53	221	106	191,5	473	-	0	AU85KGO
350	3	440	266	78	542	808	70,2	221	106	191,5	473	-	0	AU85KGO
400	3	485	308	102	627	935	118	280	131	242,5	601	-	0	A17UKKO
450	3	541	333	114	652	985	141	280	131	242,5	601	-	0	A17UKKO
500	3	600	358	127	647	1005	188	249	148	276,5	702	-	0	A21UKKO
600	3	700	442	154	813	1255	374,9	343	213	415,0	940	-	0	A40UKMO
Lug								ASR						
DN	PS	D	B	C	H1	H	kg	H2	L1	L	M	ZB	P	Kod
50	16	151	60	43	216	276	5,2	96	48	76,0	163	-	0	AU02FN0
65	16	171	67	46	255	322	6,3	115	56	91,0	195	-	0	AU04KBO
80	16	188	89	46	282	371	10,7	137	66	111,0	217	-	0	AU08KCO
100	16	218,5	103	52	341	444	14,8	165	78	135,5	299	ADP	10	AU20KE0
125	16	250	119	56	352	471	18,3	165	78	135,5	299	-	0	AU20KE0
150	16	275	130,5	56	382	512,5	24,8	182	86	152,5	348,5	-	0	AU30KDO
200	16	330	170,5	60	461	631,5	43,2	221	106	191,5	473	-	0	AU85KGO
250	10	402	203	68	514	717	66,3	249	116	212,5	560	-	0	A12UKHO
300	10	472	236	78	539	775	77,3	249	116	212,5	560	-	0	A12UKHO
350	10	520	260	78	691	951	112	280	131	242,5	601	MSC	90	A17UKKO
400	10	596	300	102	730	1030	209,9	383	117,5	356,0	738	-	0	A25UKKO
450	10	640	333	114	755	1088	223,9	383	117,5	356,0	738	-	0	A25UKKO
500	10	710	358	127	861	1219	348,9	343	213	415,0	940	MSC	120	A40UKMO
200	3	330	170,5	60	439	609,5	36,4	199	96	173,0	397	-	0	AU50KFO
250	3	402	203	68	464	667	47,4	199	96	173,0	397	-	0	AU50KFO
300	3	472	236	78	511	747	65,2	221	106	191,5	473	-	0	AU85KGO
350	3	520	260	78	542	802	88,2	221	106	191,5	473	-	0	AU85KGO
U-Section								ASR						
DN	PS	D	B	C	H1	H	kg	H2	L1	L	M	ZB	P	Kod
400	3	485	237	102	627	864	153	280	131	242,5	601	-	0	A17UKKO
450	3	514	237	114	652	889	171	280	131	242,5	601	-	0	A17UKKO
500	3	715	237	127	647	884	232	249	148	276,5	702	-	0	A21UKKO
600	3	840	237	154	813	1050	443,9	343	213	415,0	940	-	0	A40UKMO

Tekniska data – GEMÜ 481 med pneumatiskt manöverdon typ DR/SC



Styrmedium

Filtrerad, torr tryckluft, inget korrosivt medium

Temperaturområde

-40 till +80 °C, andra temperaturer på begäran

Styrtryck

6–8 bar

Vridvinkel

20° inställningsbar (75° till 95°)

90°

12 Beställningsdata – GEMÜ 481 med pneumatiskt manöverdon typ DR/SC

12 Manöverdonsstorlek*

Driftryck 16 bar (se beställningsuppgifter – driftryck kod 3)

DN	Pneumatiskt dubbelverkande	Kod	Pneumatiskt enkelverkande	Kod
25	DR0015U F03F05 N S11A	DU01AW0	SC0015U 8 F03F05 N S11A	SU01KW0
40	DR0015U F03F05 N S11A	DU01AW0	SC0015U 8 F03F05 N S11A	SU01KW0
50	DR0015U F03F05 N S11A	DU01AW0	SC0015U 8 F03F05 N S11A	SU01KW0
65	DR0015U F03F05 N S11A	DU01AW0	SC0060U 6 F05F07 N S14A	SU06KP0
80	DR0030U F05F07 N S14A	DU03AP0	SC0100U 6 F05F07 N S17A	SU10KC0
100	DR0060U F05F07 N S14A	DU06AP0	SC0150U 6 F05F07 N S17A	SU15KC0
125	DR0100U F05F07 N S17A	DU10AC0	SC0220U 6 F07F10 N S22A	SU22KD0
150	DR0150U F07F10 N S17A	DU15AE0	SC0300U 6 F07F10 N S22A	SU30KD0
200	DR0220U F07F10 N S22A	DU22AD0	SC0600U 6 F10F12 N S27A	SU60KG0

Driftryck 10 bar (se beställningsuppgifter – driftryck kod 2)

250	DR0300U F07F10 N S22A	DU30AD0	SC0900U 6 F10F12 N S27A	SU90KG0
300	DR0300U F07F10 N S22A	DU30AD0	SC0900U 6 F10F12 N S27A	SU90KG0
350	DR0450U F10F12 N S27A	DU45AG0	SC1200U 6 F10F12 N S27A	S12UKG0
400	DR1200U F14 N S36A	D12UAK0	SC3000U 6 F14 N S36A	S30UJK0
450	DR1200U F14 N S36A	D12UAK0	SC3000U 6 F14 N S36A	S30UJK0
500	DR1200U F14 N S36A	D12UAK0	SC3000U 6 F14 N S36A	S30UJK0
600	DR2000U F16 N S46A	D20UAL0	SC5000U 6 F16F25 N S46A	S50UKS0

Driftryck 3 bar (se beställningsuppgifter – driftryck kod 0)

200	DR0150U F07F10 N S17A	DU15AE0	SC0450U 6 F10F12 N S27A	SU45KG0
250	DR0150U F07F10 N S17A	DU15AE0	SC0450U 6 F10F12 N S27A	SU45KG0
300	DR0220U F07F10 N S22A	DU22AD0	SC0600U 6 F10F12 N S27A	SU60KG0
350	DR0220U F07F10 N S22A	DU22AD0	SC0600U 6 F10F12 N S27A	SU60KG0
400	DR0900U F14 N S36A	DU90AK0	SC2000U 6 F14 N S36A	S20UJK0
450	DR0900U F14 N S36A	DU90AK0	SC2000U 6 F14 N S36A	S20UJK0
500	DR0900U F14 N S36A	DU90AK0	SC2000U 6 F14 N S36A	S20UJK0
600	DR2000U F16 N S46A	D20UAL0	SC4000U 6 F16 N S46A	S40UKL0

* Dimensionering för vätskor +20 till +80°C vid styrtryck 6 bar

Beställningsexempel	1	2	3	4	5	6	7	8	9	10	11	12
Kod	481	Beställningsuppgifter vridspjällsventil (sidan 3)										DU15AD0

Manöverdonsmått DR/SC [mm]

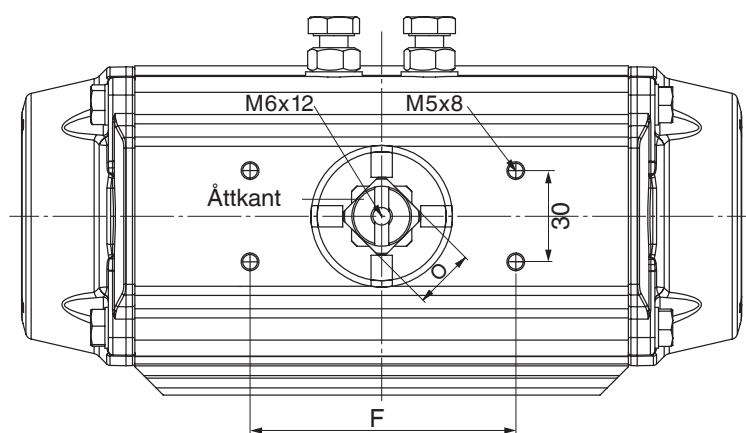
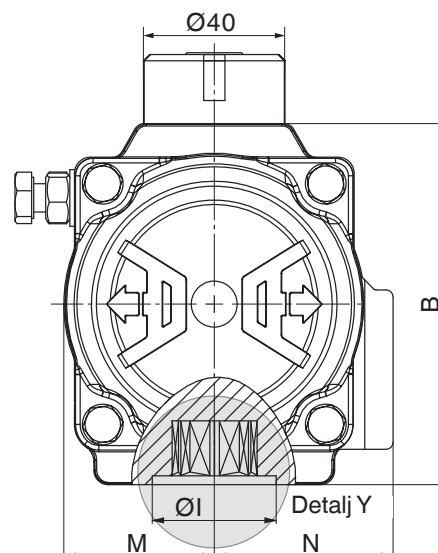
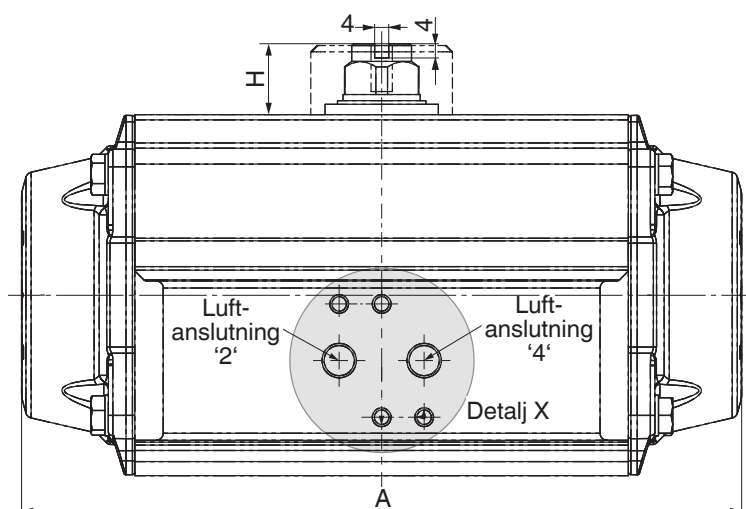

Typ 0015U-1200U

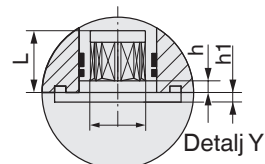
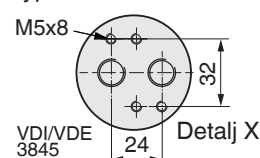

Typ 2000U-4000U

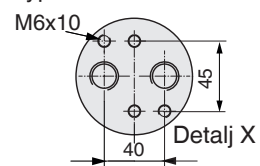

Typ 5000U

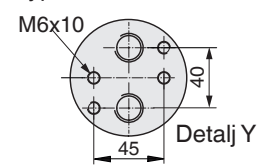

Typ	0015U	0030U	0060U	0100U	0150U	0220U	0300U	0450U	0600U	0900U	1200U	2000U	3000U	4000U	5000U
ISO Fläns	F04	F04 F05/07	F05/07	F05/07	F07/10	F07/10	F07/10	F10/12	F10/12	F14	F14	F16	F16	F16	F25
Åttkant	11	14	14	17	17	22	22	27	27	36	36	46	46	46	55
L	12	16	19	19	25	24	24	29	40	38	38	48	48	49	57
Luftanslutning	G 1/8	G 1/8	G 1/8	G 1/8	G 1/4	G 1/4	G 1/4	G 1/4	G 1/4	G 1/4	G 1/4	G 3/8	G 1/2	G 1/2	G 1/2
A	136,0	153,5	203,5	241,0	259,0	304,0	333,0	394,5	422,5	474,0	528,0	605,0	710,0	812,0	876,0
B	69,0	85,0	102,0	115,0	127,0	145,0	157,0	177,0	196,0	220,5	245,0	298,5	330,0	383,0	410,0
F	80	80	80	80	80	80	80	80	80	130	130	130	130	130	130
H	20	20	20	20	20	30	30	30	30	50	50	50	50	50	50
Ø I	30	35	35	40	55	55	55	70	70	100	100	130	130	130	200
M	29,0	36,0	42,5	49,5	55,5	64,0	69,5	80,0	88,0	99,0	110,0	131,0	165,0	185,5	204,0
N	43,0	48,5	50,5	56,5	63,0	72,0	77,0	86,0	93,0	101,0	111,5	131,0	165,0	185,5	214,0
O	11	11	17	17	17	27	27	27	27	36	36	36	36	36	36
h	0,5	0,5	0,5	1,5	1,5	1,5	1,5	1,5	1,5	2	2	2,5	2,5	2,5	2,5
h1	1,5	1,5	2	1,5	2	2	2	3	3	3	3	2,5	2,5	4	3,5
L	11	11/16	19	19	19	19	25	32	40	38	38	38	40	57	57
Vikt [kg]															
DR	1,0	1,6	2,7	3,7	5,2	8,0	9,8	14,0	18,0	24,0	34,0	53,0	74,0	123,0	127,0
SC	1,1	1,7	3,1	4,3	6,1	9,3	12,0	17,0	22,0	33,0	42,0	67,0	93,0	155,0	169,0

Mått – GEMÜ 481 vridspjällsventil med pneumatiskt manöverdon
GEMÜ DR – dubbelverkande [mm]

Wafer

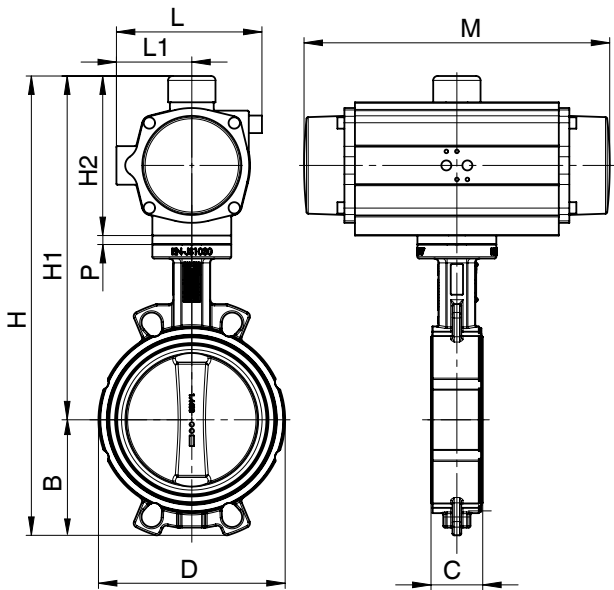

Lug

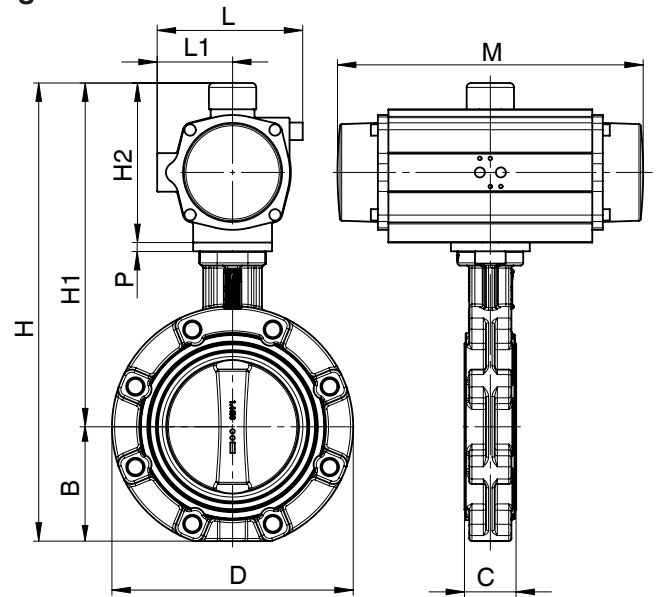

U-sektion

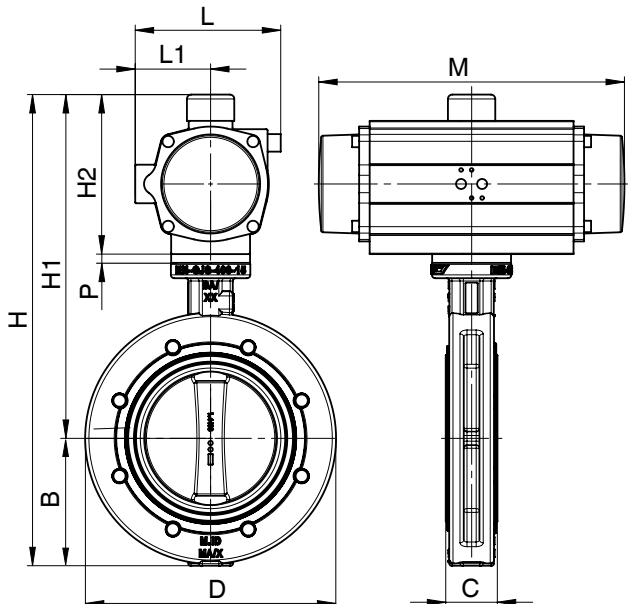

Tillbehör (ZB)

Adapterplatta (ADP)

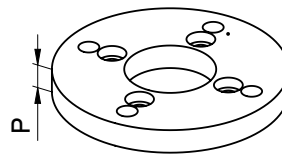

Distansstycke (DIS)

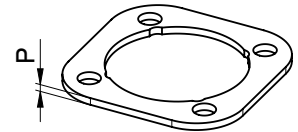

Adapterplatta (ADP)

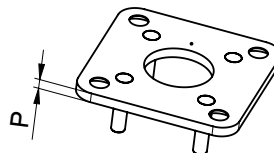

Monteringssats (MSC)

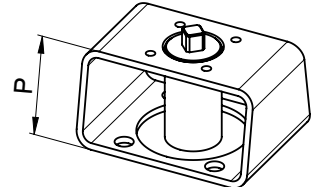

**Mått – GEMÜ 481 vridspjällsventil med pneumatiskt manöverdon
GEMÜ DR – dubbelverkande [mm]**

Ventilhus typ								Manöverdon						
Wafer								DR						
DN	PS	D	B	C	H1	H	kg	H2	L1	L	M	ZB	P	Kod
25	16	59,5	41,3	25	175	216,3	2,2	69	43	72,0	136	DIS	6	DU01AW0
40	16	75,5	53,8	33	195	248,8	2,5	69	43	72,0	136	DIS	6	DU01AW0
50	16	91	60,2	43	195	255,2	4	69	43	72,0	136	DIS	6	DU01AW0
65	16	111	67,6	46	215	282,6	4,6	69	43	72,0	136	DIS	6	DU01AW0
80	16	130	90,4	46	233	323,4	5,6	85	48,5	84,5	153,5	DIS	3	DU03AP0
100	16	150	105,1	52	268	373,1	8,2	102	50,5	93,0	203,5	-	0	DU06AP0
125	16	179	119,6	56	299	418,6	10,2	102	50,5	93,0	203,5	DIS	10	DU06AC0
150	16	210	131,5	56	327	458,5	14	127	63	118,5	259	-	0	DU15AD0
200	16	264	160	60	388	548	21,1	145	72	136,0	304	DIS	3	DU22AD0
250	10	314	195,3	68	422	617,3	32,4	157	77	146,5	333	-	0	DU30AD0
300	10	364	236,3	78	447	683,3	41	157	77	146,5	333	-	0	DU30AD0
350	10	440	266	78	498	764	62,5	177	86	166,0	394,5	-	0	DU45AG0
400	10	485	308	102	592	900	107,5	245	111,5	221,5	528	-	0	D12UAK0
450	10	541	333	114	617	950	130,5	245	111,5	221,5	528	-	0	D12UAK0
500	10	600	358	127	643	1001	155,5	245	111,5	221,5	528	-	0	D12UAK0
600	10	700	442	154	759,5	1201,5	245	289,5	131	262,0	605	-	0	D20UAL0
200	3	264	160	60	367	527	18,1	127	63	118,5	259	-	0	DU15AE0
250	3	314	195,3	68	392	587,3	27,6	127	63	118,5	259	-	0	DU15AE0
300	3	364	236,3	78	435	671,3	39,2	145	72	136,0	304	-	0	DU22AD0
350	3	440	266	78	481	747	56,4	145	72	136,0	304	ADP	15	DU22AD0
400	3	485	308	102	567,5	875,5	97	220,5	101	200,0	474	-	0	DU90AK0
450	3	541	333	114	592,5	925,5	120	220,5	101	200,0	474	-	0	DU90AK0
500	3	600	358	127	618,5	976,5	145	220,5	101	200,0	474	-	0	DU90AK0
600	3	700	442	154	768,5	1210,5	245	298,5	131	262,0	605	-	0	D20UAL0
Lug								DR						
DN	PS	D	B	C	H1	H	kg	H2	L1	L	M	ZB	P	Kod
50	16	151	60	43	195	255	4,7	69	43	72,0	136	DIS	6	DU01AW0
65	16	171	67	46	215	282	5	69	43	72,0	136	DIS	6	DU01AW0
80	16	188	89	46	233	322	8,6	85	48,5	84,5	153,5	DIS	3	DU03AP0
100	16	218,5	103	52	268	371	10,2	102	50,5	93,0	203,5	-	0	DU06AP0
125	16	250	119	56	299	418	13,7	102	50,5	93,0	203,5	DIS	10	DU06AC0
150	16	275	130,5	56	327	457,5	19,4	127	63	118,5	259	-	0	DU15AD0
200	16	330	170,5	60	388	558,5	29,4	145	72	136,0	304	DIS	3	DU22AD0
250	10	402	203	68	422	625	42,2	157	77	146,5	333	-	0	DU30AD0
300	10	472	236	78	447	683	53,2	157	77	146,5	333	-	0	DU30AD0
350	10	520	260	78	498	758	80,5	177	86	166,0	394,5	-	0	DU45AG0
400	10	596	300	102	592	892	145,5	245	111,5	221,5	528	-	0	D12UAK0
450	10	640	333	114	617	950	159,5	245	111,5	221,5	528	-	0	D12UAK0
500	10	710	358	127	643	1001	201,5	245	111,5	221,5	528	-	0	D12UAK0
600	10	840	442	154	759,5	1201,5	289	289,5	131	262,0	605	-	0	D20UAL0
200	3	330	170,5	60	367	537,5	26,4	127	63	118,5	259	-	0	DU15AE0
250	3	402	203	68	392	595	37,4	127	63	118,5	259	-	0	DU15AE0
300	3	472	236	78	435	671	51,4	145	72	136,0	304	-	0	DU22AD0
350	3	520	260	78	481	741	74,4	145	72	136,0	304	ADP	15	DU22AD0
400	3	596	300	102	567,5	867,5	135	220,5	101	200,0	474	-	0	DU90AK0
U-Sektion								DR						
DN	PS	D	B	C	H1	H	kg	H2	L1	L	M	ZB	P	Kod
400	3	485	237	102	567,5	804,5	132	220,5	101	200,0	474	-	0	DU90AK0
450	3	541	237	114	592,5	829,5	150	220,5	101	200,0	474	-	0	DU90AK0
500	3	715	237	127	618,5	855,5	189	220,5	101	200,0	474	-	0	DU90AK0
600	3	840	237	154	768,5	1005,5	314	298,5	131	262,0	605	-	0	D20UAL0

Mått – GEMÜ 481 vridspjällsventil med pneumatiskt manöverdon
GEMÜ SC – enkelverkande [mm]

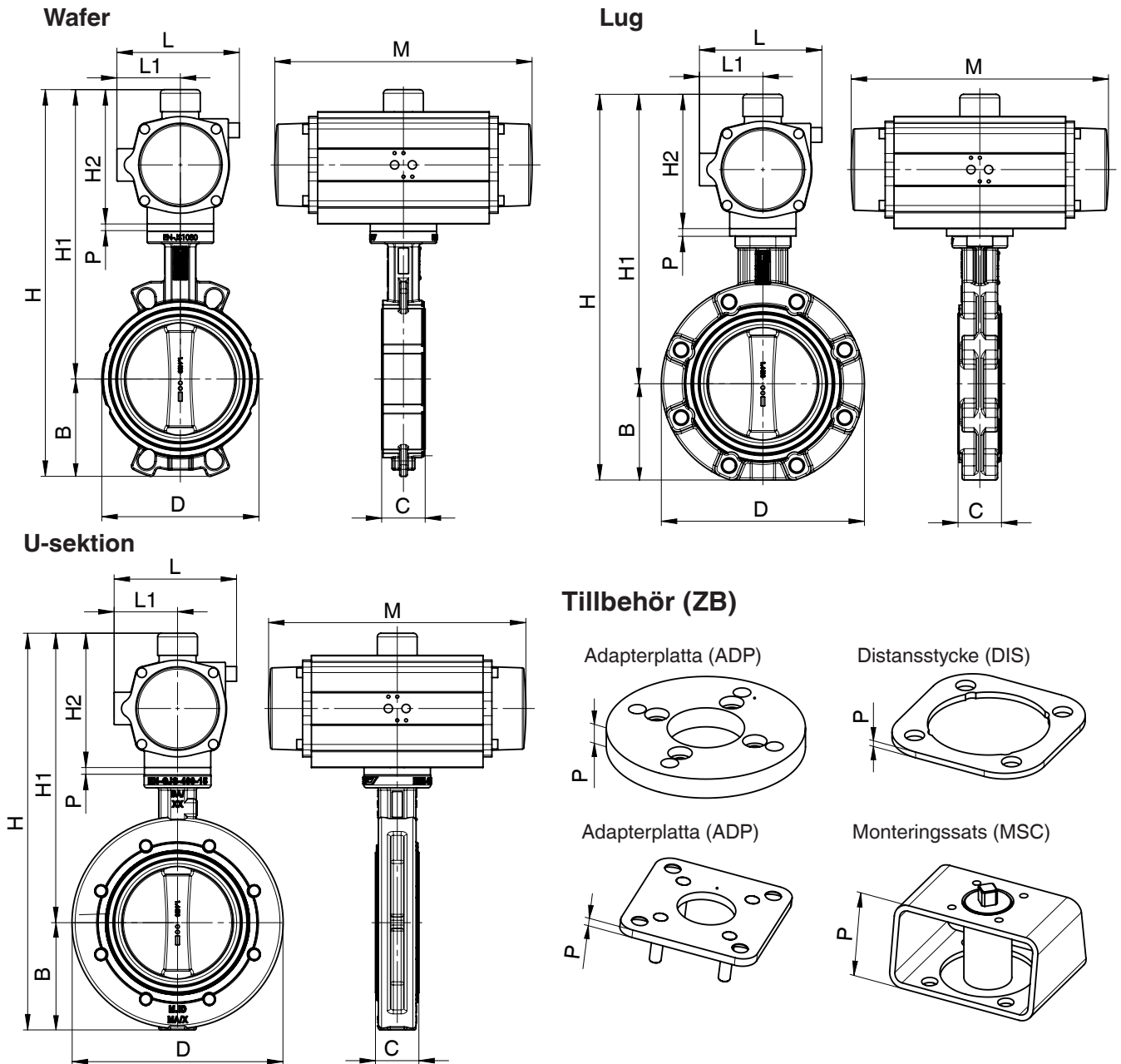

Slaglängdsbegränsning på begäran

**Mått – GEMÜ 481 vridspjällsventil med pneumatiskt manöverdon
GEMÜ SC – enkelverkande [mm]**

Ventilhustyp								Manöverdon						
Wafer								SC						
DN	PS	D	B	C	H1	H	kg	H2	L1	L	M	ZB	P	Kod
25	16	59,5	41,3	25	175	216,3	2,6	69	43	72,0	136	DIS	6	SU01KW0
40	16	75,5	53,8	33	195	248,8	2,9	69	43	72,0	136	DIS	6	SU01KW0
50	16	91	60,2	43	195	255,2	4,4	69	43	72,0	136	DIS	6	SU01KW0
65	16	111	67,6	46	242	309,6	6,8	102	50,5	93,0	203,5	-	0	SU06KP0
80	16	130	90,4	46	260	350,4	8,4	115	56,5	106,0	241	-	0	SU10KC0
100	16	150	105,1	52	293	398,1	12	127	63	118,5	259	-	0	SU15KC0
125	16	179	119,6	56	332	451,6	17,3	145	72	136,0	304	-	0	SU22KD0
150	16	210	131,5	56	357	488,5	21,2	157	77	146,5	333	-	0	SU30KD0
200	16	264	160	60	436	596	36,7	196	93	181,0	422,5	-	0	SU60KG0
250	10	314	195,3	68	485,5	680,8	53,8	220,5	101	200,0	474	-	0	SU90KG0
300	10	364	236,3	78	510,5	746,8	62,4	220,5	101	200,0	474	-	0	SU90KG0
350	10	440	266	78	566	832	93,1	245	111,5	221,5	528	-	0	S12UKG0
400	10	485	308	102	1057	1365	174,2	710	165	330,0	710	-	0	S30UKK0
450	10	541	333	114	1082	1415	197,3	710	165	330,0	710	-	0	S30UKK0
500	10	600	358	127	1108	1466	222,3	710	165	330,0	710	-	0	S30UKK0
600	10	700	442	154	1346	1788	361	876	214	418,0	876	-	0	S50UKS0
200	3	264	160	60	417	577	30,8	177	86	166,0	394,5	-	0	SU45KG0
250	3	314	195,3	68	442	637,3	40,3	177	86	166,0	394,5	-	0	SU45KG0
300	3	364	236,3	78	486	722,3	54,8	196	93	181,0	422,5	-	0	SU60KG0
350	3	440	266	78	517	783	72	196	93	181,0	422,5	-	0	SU60KG0
400	3	485	308	102	636,5	944,5	136,2	289,5	131	262,0	605	-	0	S20UKK0
450	3	541	333	114	661,5	994,5	159,2	289,5	131	262,0	605	-	0	S20UKK0
500	3	600	358	127	687,5	1045,5	184,2	289,5	131	262,0	605	-	0	S20UKK0
600	3	700	442	154	853	1295	342	383	185,5	371,0	812	-	0	S40UKL0
Lug								SC						
DN	PS	D	B	C	H1	H	kg	H2	L1	L	M	ZB	P	Kod
50	16	151	60	43	195	255	5,1	69	43	72,0	136	DIS	6	SU01KW0
65	16	171	67	46	242	309	7,2	102	50,5	93,0	203,5	-	0	SU06KP0
80	16	188	89	46	260	349	11,4	115	56,5	106,0	241	-	0	SU10KC0
100	16	218,5	103	52	293	396	14	127	63	118,5	259	-	0	SU15KC0
125	16	250	119	56	332	451	20,8	145	72	136,0	304	-	0	SU22KD0
150	16	275	130,5	56	357	487,5	26,6	157	77	146,5	333	-	0	SU30KD0
200	16	330	170,5	60	436	606,5	45	196	93	181,0	422,5	-	0	SU60KG0
250	10	402	203	68	485,5	688,5	63,6	220,5	101	200,0	474	-	0	SU90KG0
300	10	472	236	78	510,5	746,5	74,6	220,5	101	200,0	474	-	0	SU90KG0
350	10	520	260	78	566	826	111,1	245	111,5	221,5	528	-	0	S12UKG0
400	10	596	300	102	1057	1357	212,2	710	165	330,0	710	-	0	S30UKK0
450	10	640	333	114	1082	1415	226,3	710	165	330,0	710	-	0	S30UKK0
500	10	710	358	127	1108	1466	268,3	710	165	330,0	710	-	0	S30UKK0
600	10	840	442	154	1346	1788	405	876	214	418,0	876	-	0	S50UKS0
200	3	330	170,5	60	417	587,5	39,1	177	86	166,0	394,5	-	0	SU45KG0
250	3	402	203	68	442	645	50,1	177	86	166,0	394,5	-	0	SU45KG0
300	3	472	236	78	486	722	67	196	93	181,0	422,5	-	0	SU60KG0
350	3	520	260	78	517	777	90	196	93	181,0	422,5	-	0	SU60KG0
400	3	596	300	102	636,5	936,5	174,2	289,5	131	262,0	605	-	0	S20UKK0
U-sektion								SC						
DN	PS	D	B	C	H1	H	kg	H2	L1	L	M	ZB	P	Kod
400	3	485	237	102	636,5	873,5	171,2	289,5	131	262,0	605	-	0	S20UKK0
450	3	541	237	114	661,5	898,5	189,2	289,5	131	262,0	605	-	0	S20UKK0
500	3	715	237	127	687,5	924,5	228,2	289,5	131	262,0	605	-	0	S20UKK0
600	3	840	237	154	853	1090	411	383	185,5	371,0	812	-	0	S40UKL0

Tekniska data för elmotor drivna GEMÜ-manöverdon

Min./max. omgivningstemperatur

-10 till +60°C

Särskilda egenskaper

Manuell nödstyrning som standard

Kapslingsklass enligt EN 60529

IP 65

Spänningsförsörjning

Nominell spänning 12 V, 24 V DC/12 V, 24 V AC
 Nominell frekvens (vid nominell spänning, AC) 50/60 Hz
 Spänningstolerans +10 %/-15 %

Vikt

Manöverdonsutförande 1006, 1015	0,9 kg
Manöverdonsutförande 2015	1,2 kg
Manöverdonsutförande 3035	2,4 kg
Manöverdonsutförande 2070	4,6 kg
Manöverdonsutförande 4100/4200	11,0 kg

Ställtider

Manöverdonsutförande 1006	ca 4 s
Manöverdonsutförande 1015, 2015	ca 11 s
Manöverdonsutförande 2070, 3035	ca 15 s
Manöverdonsutförande 4100	ca 20 s
Manöverdonsutförande 4200	ca 16 s

Direktiv

Maskindirektivet 98/37/EG, bilaga II B
 EMC-direktivet 89/336/EG

Manöverdonsutförande/funktionsmodul

Manöverdonsutförande (kod)	Funktionsmodul (kod)				
	A0	AE	00	0E	0P
1006, 1015, 2015, 3035	X	X	-	-	-
2070*, 4100*, 4200*	-	-	X	X	X

*Kombinationer spänning/funktionsmodul se datablad GEMÜ 9468

Effekt- och strömförbrukning [W]

Manöverdonsutförande (kod)	12 V DC A0, AE	12 V AC A0, AE	24 V DC 00/0E/0P	24 V AC 00/0E/0P
1006	30	30	-	-
1015	30	-	-	-
2015	-	30	-	-
3035	-	-	30	-
2070	-	-	63	63
4100	-	-	105	140
4200	-	-	90	110

Vridområde

Nominellt vridområde 90°
 Maximalt vridområde 93°
 Inställningsområde gränslägesbrytare – manöverdonsutförande
 1006, 1015, 2015, 3035 min. 2–12°/max. 76–91°
 2070, 4100, 4200 min. 0–20°/max. 70–93°

Intermittensfaktor

100 % ED

Tilldelning manöverdonsutförande/nominell diameter

DN	PS [bar]	Manöverdonsutförande (kod)						
		1006	1015	2015	3035	2070	4100	4200
25	16	X	-	-	-	-	-	-
40		-	X	X	-	-	-	-
50 - 65		-	-	-	X	-	-	-
80 - 100		-	-	-	-	X	-	-
125		-	-	-	-	-	X	-
150		-	-	-	-	-	-	X
200 - 250	3	-	-	-	-	-	-	X

Observera: För anslutnings- och kabelschema för elmotor drivna GEMÜ-manöverdon, se datablad

Manöverdonsutförande kod 1006, 2006, 1015, 3035 – datablad GEMÜ 9428
 Manöverdonsutförande kod 2070, 4100, 4200 – datablad GEMÜ 9468

Tekniska data för elmotor drivna GEMÜ-manöverdon

Tilldelning – manöverdonsutförande/spänningsfrekvens

Manöverdonsutförande (kod)	Spänningsfrekvens (kod)			
	12 V DC	12 V AC	24 V DC	24 V AC
	B1	B4	C1	C4
1006 (6 Nm)	X	X	X	X
1015 (15 Nm)	X	-	X	-
2015 (15 Nm)	-	X	-	X
3035 (35 Nm)	-	-	X	-
2070 (70 Nm)	-	-	X	X
4100 (100 Nm)	-	-	X	X
4200 (200 Nm)	-	-	X	X

Manöverdonsmaterial

Manöverdonsutförande	1006, 1015	2015, 3035	2070	4100, 4200
Husunderdel	PP (30 % GF)	PP (30 % GF)	ABS	Aluminium
Husöverdel	PPO (10 % GF)	PP (30 % GF)	ABS	Aluminium
Visuell indikering	PPR natur	PPR natur	PPR natur	PMMA

Beställningsuppgifter – GEMÜ 488 med elmotor drivet GEMÜ-manöverdon

14 Spänning/frekvens	Kod
12 V DC	B1
12 V AC 50/60 Hz	B4
24 V DC	C1
24 V AC 50/60 Hz	C4

15 Funktionsmodul	Kod
ÖPPEN/STÄNGD-styrning med relä, ej reverserbar	00*
ÖPPEN/STÄNGD-styrning med 2 extra potentialfria gränslägesbrytare, med relä, ej reverserbar	0E*
ÖPPEN/STÄNGD-styrning med potentiometerutgång, med relä, ej reverserbar	0P*
ÖPPEN/STÄNGD-styrning standard	A0**
ÖPPEN/STÄNGD-styrning med 2 extra potentialfria gränslägesbrytare	AE**
* Monteringshöjd 1	** Monteringshöjd 2

16 Manöverdonsutförande	Kod
Vridmoment 6 Nm, ställtid 4 s; anslutningsspänning B1,C1,B4,C4	1006
Vridmoment 15 Nm, ställtid 11 s; anslutningsspänning C1	1015
Vridmoment 15 Nm, ställtid 11 s; anslutningsspänning C4	2015
Vridmoment 35 Nm, ställtid 15 s; anslutningsspänning C1	3035
Vridmoment 70 Nm, ställtid 15 s; anslutningsspänning C1, C4	2070
Vridmoment 100 Nm, ställtid 20 s; anslutningsspänning C1, C4	4100
Vridmoment 200 Nm, ställtid 16 s; anslutningsspänning C1, C4	4200
Dimensionering för vätskor +20 till +80°C	

Beställningsexempel	1	2	3	4	5	6	7	8	9	10	14	15	16
Kod	488	Beställningsuppgifter vridspjällsventil (sidan 4)									C1	A0	2070

Mått – GEMÜ 488 vridspjällsventil för elmotor drivna GEMÜ-manöverdon [mm]

Code 1006, 1015, 2015

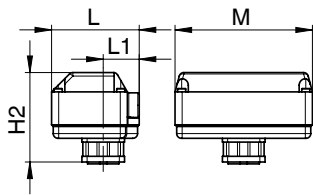

Code 3035

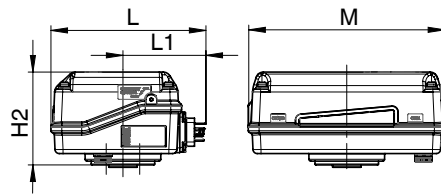

Code 2070

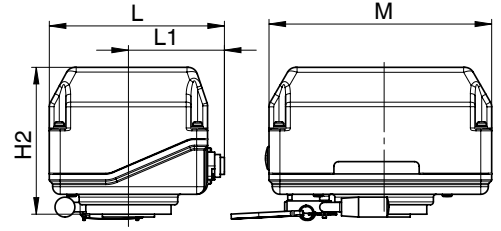

Code 4100, 4200

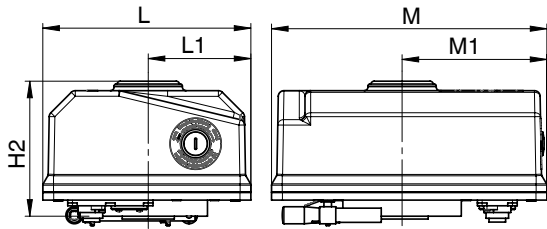

Wafer

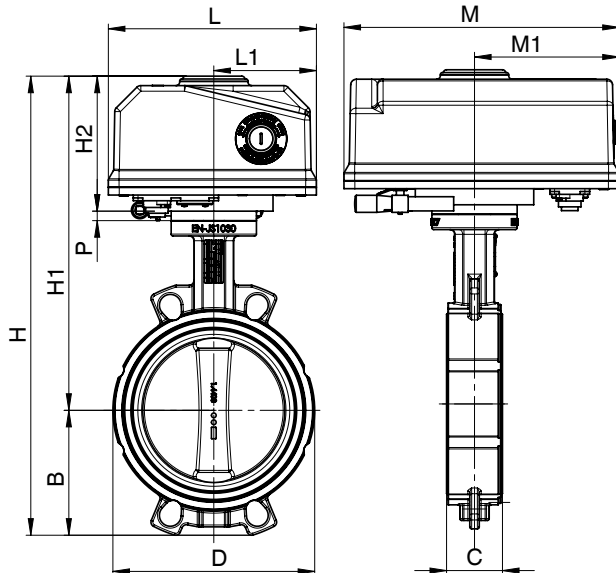

Lug

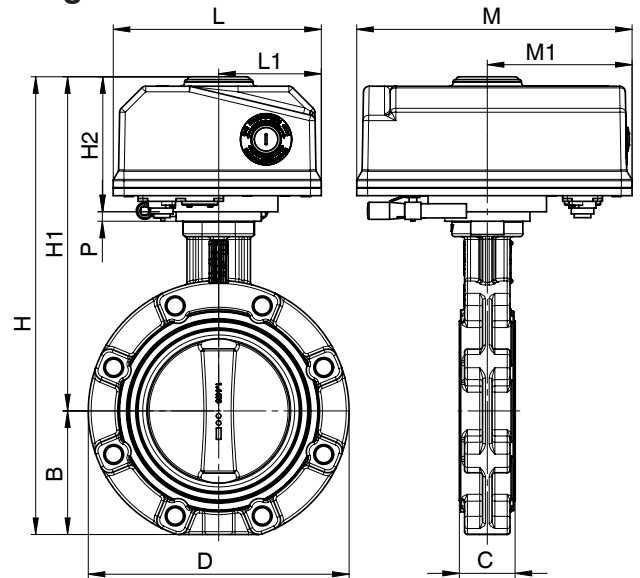

U-sektion

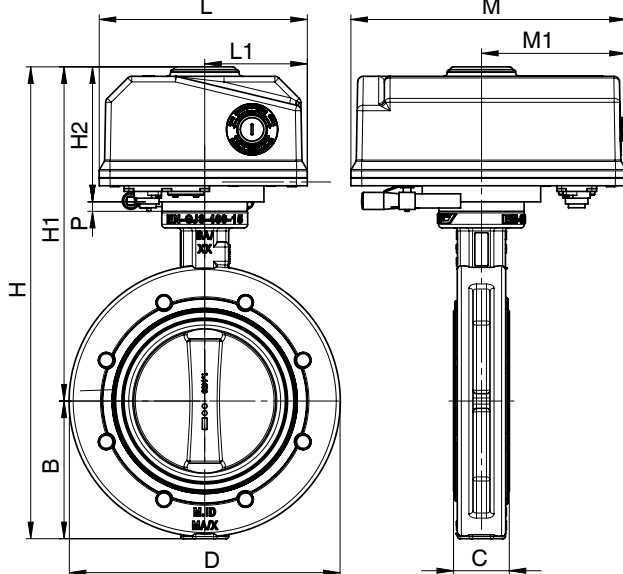

Tillbehör (ZB)

Adapterplatta (ADP)

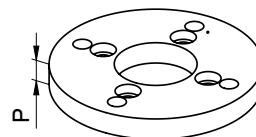

Distansstycke (DIS)

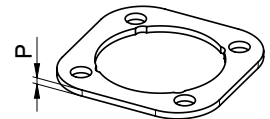

Adapterplatta (ADP)

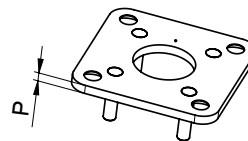

Monteringsats (MSC)

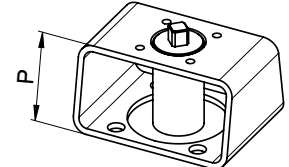

Mått – GEMÜ 488 vridspjällsventil för elmotor drivna GEMÜ-manöverdon [mm]

Ventilhus typ								Manöverdon								
Wafer								9428/9468								
DN	PS	C	D	B	H1	H	kg	Manöverdonsutförande	H1	H2	L	L1	M	M1	ZB	P
25	16	25	59,5	41,3	221	262,3	2,1	1006	221	121	108,0	53,0	145,0	-	-	0
40	16	33	75,5	53,8	241	294,8	2,7	1015/2015	241	121	108,0	53,0	145,0	-	-	0
50	16	43	91	60,2	244,5	304,7	5,4	3035	244,5	124,5	172,0	96,0	208,0	-	-	0
65	16	46	111	67,6	264,5	332,1	6	3035	264,5	124,5	172,0	96,0	208,0	-	-	0
80	16	46	130	90,4	300	390,4	8,6	2070	300	155	167,0	83,5	235,0	-	-	0
100	16	52	150	105,1	321	426,1	10,1	2070	321	155	167,0	83,5	235,0	-	-	0
125	16	56	179	119,6	387	506,6	18,5	4100	387	200	207,0	102,0	277,5	146,5	-	0
150	16	56	210	131,5	400	531,5	19,6	4200	400	200	207,0	102,0	277,5	146,5	-	0
200	3	60	264	160	440	600,0	23,7	4200	440	200	207,0	102,0	277,5	146,5	-	0
250	3	68	314	195,3	465	660,3	33,2	4200	465	200	207,0	102,0	277,5	146,5	-	0

Lug								9428/9468								
DN	PS	C	D	B	H1	H	kg	Manöverdonsutförande	H1	H2	L	L1	M	M1	ZB	P
50	16	43	151	60	244,5	304,5	6,1	3035	244,5	124,5	172,0	96,0	208,0	-	-	0
65	16	46	171	67	264,5	331,5	6,4	3035	264,5	124,5	172,0	96,0	208,0	-	-	0
80	16	46	188	89	300	389	11,6	2070	300	155	167,0	83,5	235,0	-	-	0
100	16	52	218,5	103	321	424	12,1	2070	321	155	167,0	83,5	235,0	-	-	0
125	16	56	250	119	387	506	22	4100	387	200	207,0	102,0	277,5	146,5	-	0
150	16	56	275	130,5	400	530,5	25	4200	400	200	207,0	102,0	277,5	146,5	-	0
200	3	60	330	170,5	440	610,5	32	4200	440	200	207,0	102,0	277,5	146,5	-	0
250	3	68	402	203	465	668	43	4200	465	200	207,0	102,0	277,5	146,5	-	0

U-sektion								GEMÜ 9428/9468								
DN	PS	C	D	B	H1	H	kg	Manöverdonsutförande	H1	H2	L	L1	M	M1	ZB	P
150	16	56	269	146	400	546	28	4200	400	200	207,0	102,0	277,5	146,5	-	0
200	3	60	343	175	440	615	32	4200	440	200	207,0	102,0	277,5	146,5	-	0
250	3	68	404	205	465	670	46	4200	465	200	207,0	102,0	277,5	146,5	-	0

Tekniska data för elmotor drivna J+J-manöverdon

Min./max. omgivningstemperatur
-20 till +70 °C

Kapslingsklass enligt EN 60529
IP 67

Särskilda egenskaper
Manuell nödstyrning som standard

Vikt	
Manöverdonsutförande J3C20	1,8 kg
Manöverdonsutförande J3C35	1,9 kg
Manöverdonsutförande J3C55	2,3 kg
Manöverdonsutförande J3C85	3,0 kg
Manöverdonsutförande J3C14/J3C30	5,2 kg

Spänningsförsörjning	
Märkspänning	
Utförande J3C14/30	24 V AC/DC (0/+5 %)
Utförande J3C20/35/55/85	24–240 V AC/DC (± 0%)
Alla utföranden	85–240 V AC/DC (0/+ 5%)
Nominell frekvens (vid nominell spänning, AC)	50/60 Hz
Intermittensfaktor	75 %

Ställtider (± 10%)		
Manöverdons- utförande	24- 240 V AC/DC Kod U5	24 V, 85-240 V AC/DC Kod C5, S5
J3C20	10 s	-
J3C35	10 s	-
J3C55	14 s	-
J3C85	30 s	-
J3C14	-	34 s
J3C30	-	58 s

Tilldelning manöverdonsutförande/nominell diameter							
DN	PS [bar]	Standardmässigt manöverdonsutförande (kod)					
		J3C20	J3C35	J3C55	J3C85	J3C14	J3C30
25 - 50	16	X	-	-	-	-	-
65		-	X	-	-	-	-
80		-	-	X	-	-	-
100 - 125		-	-	-	X	-	-
150		-	-	-	-	X	-
200		-	-	-	-	-	X
200 - 350	3	-	-	-	-	-	X

Dimensionering för EPDM, +20°C, medium vatten

Beställningsuppgifter – GEMÜ 488 med elmotordrivet J+J-manöverdon

13 Spänning	Kod
24 V AC/DC (-0/+5 %) för modell 140, 300	C5
24–240 V AC/DC (-0/+0 %) för modell 20, 35, 55, 85	U5
85–240 V AC/DC (-0/+5 %) för modell 140, 300	S5

15 Funktionsmodul	Kod
ÖPPEN/STÄNGD-styrning med 2 extra potentialfria gränslägesbrytare	AE
Reglermodul; för externt börvärde 4–20 mA	E2
Reglermodul; för externt börvärde 0–10 V DC	E1
Med BSR-batteripaket – NC	AE1
Med BSR-batteripaket – NO	AE2

16 Manöverdonsutförande	Kod
Vridmoment 20 Nm	J3C20
Vridmoment 35 Nm	J3C35
Vridmoment 55 Nm	J3C55
Vridmoment 85 Nm	J3C85
Vridmoment 140 Nm	J3C14
Vridmoment 300 Nm	J3C30

Dimensionering för vätskor +20 till +80°C

Beställningsexempel	1	2	3	4	5	6	7	8	9	10	14	15	16
Kod	488	Beställningsuppgifter vridspjällsventil									U5	AE	J3C85

(sidan 4)

Mått – GEMÜ 488 vridspjällsventil för elmotor drivna J+J-manöverdon [mm]

Code J3C20, J3C35

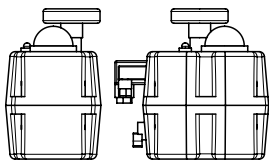

Code J3C55

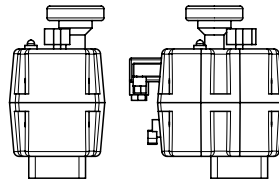

Code J3C85

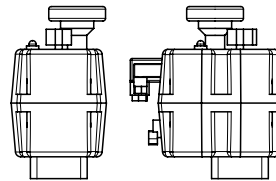

Code J3C14, J3C30

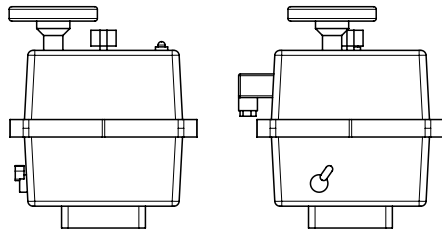

Wafer

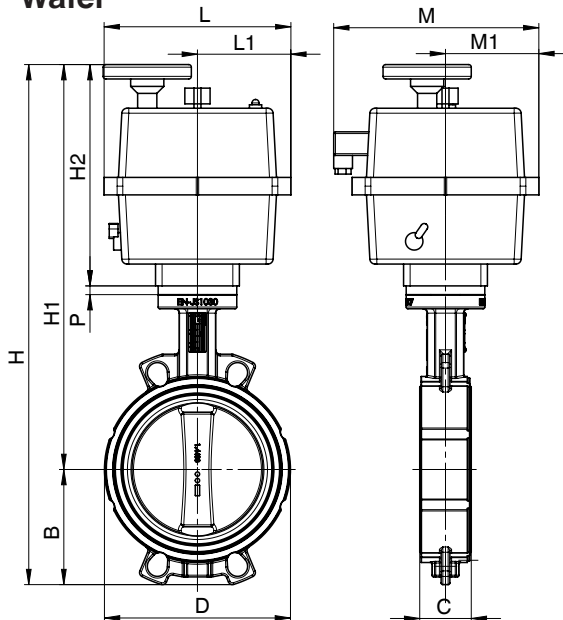

Lug

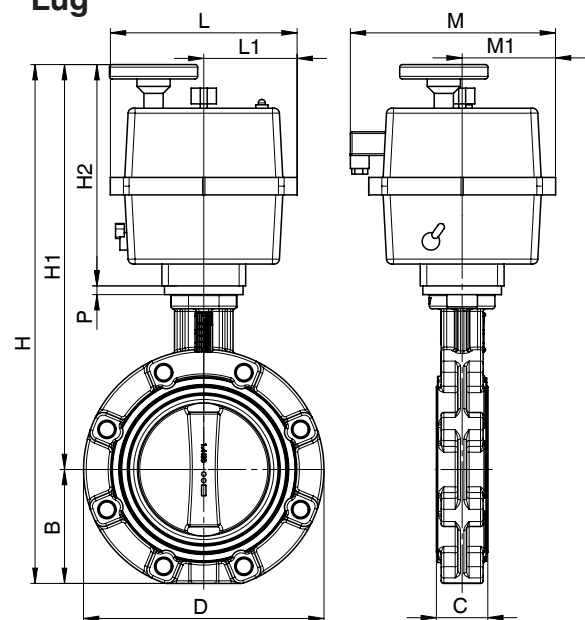

U-sektion

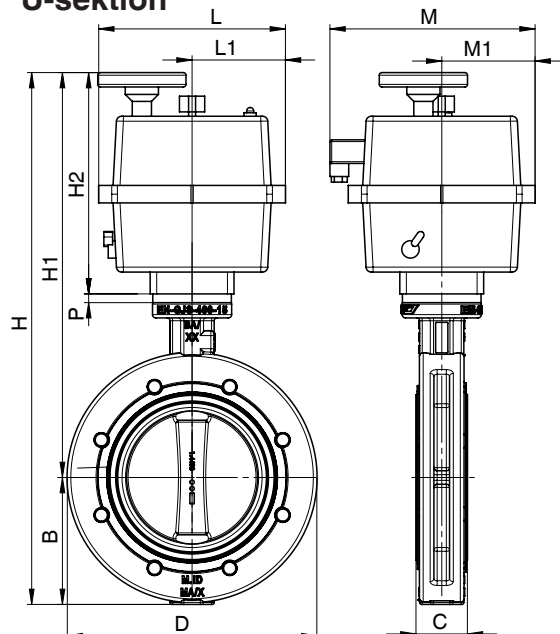

Tillbehör (ZB)

Adapterplatta (ADP)

Distansstycke (DIS)

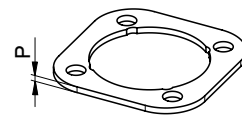
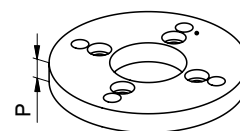

Adapterplatta (ADP)

Monteringsats (MSC)

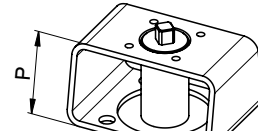
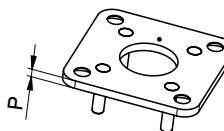

Mått – GEMÜ 488 vridspjällsventil för elmotordrivna GEMÜ-manöverdon [mm]

Ventilhustyp								Manöverdon								
Wafer								J+J								
DN	PS	C	D	B	H1	H	kg	Manöverdonsutförande	H1	H2	L	L1	M	M1	ZB	P
25	16	25	59,5	41,3	271	312,3	3	J3C20	271	171	110,0	55,0	177,0	51,0	-	0
40	16	33	75,5	53,8	291	344,8	3,3	J3C20	291	171	110,0	55,0	177,0	51,0	-	0
50	16	43	91	60,2	291	351,2	4,8	J3C20	291	171	110,0	55,0	177,0	51,0	-	0
65	16	46	111	67,6	311	378,6	5,5	J3C35	311	171	110,0	55,0	177,0	51,0	-	0
80	16	46	130	90,4	341	431,4	6,3	J3C55	341	196	110,0	55,0	177,0	51,0	-	0
100	16	52	150	105,1	362	467,1	8,5	J3C85	362	196	110,0	55,0	177,0	51,0	-	0
125	16	56	179	119,6	383	502,6	10,5	J3C85	383	196	110,0	55,0	177,0	51,0	DIS	6
150	16	56	210	131,5	454	585,5	13,8	J3C14	454	254	214,0	107,0	235,0	107,0	-	0
200	16	60	264	160	494	654	17,9	J3C30	494	254	214,0	107,0	235,0	107,0	-	0
200	3	60	264	160	494	654	17,9	J3C30	494	254	214,0	107,0	235,0	107,0	-	0
250	3	68	314	195,3	519	714,3	27,4	J3C30	519	254	214,0	107,0	235,0	107,0	-	0
300	3	78	364	236,3	544	780,3	36	J3C30	544	254	214,0	107,0	235,0	107,0	-	0
350	3	78	440	266	585	851	53,2	J3C30	575	254	214,0	107,0	235,0	107,0	ADP	10

Lug								J+J								
DN	PS	C	D	B	H1	H	kg	Manöverdonsutförande	H1	H2	L	L1	M	M1	ZB	P
50	16	43	151	60	291	351	5,5	J3C20	291	171	110,0	55,0	177,0	51,0	-	0
65	16	46	171	67	311	378	5,9	J3C35	311	171	110,0	55,0	177,0	51,0	-	0
80	16	46	188	89	341	430	9,3	J3C55	341	196	110,0	55,0	177,0	51,0	-	0
100	16	52	218,5	103	362	465	10,5	J3C85	362	196	110,0	55,0	177,0	51,0	-	0
125	16	56	250	119	383	502	14	J3C85	383	196	110,0	55,0	177,0	51,0	DIS	6
150	16	56	275	130,5	454	584,5	19,2	J3C14	454	254	214,0	107,0	235,0	107,0	-	0
200	16	60	330	170,5	494	664,5	26,2	J3C30	494	254	214,0	107,0	235,0	107,0	-	0
200	3	60	330	170,5	494	664,5	26,2	J3C30	494	254	214,0	107,0	235,0	107,0	-	0
250	3	68	402	203	519	722	37,2	J3C30	519	254	214,0	107,0	235,0	107,0	-	0
300	3	78	472	236	544	780	48,2	J3C30	544	254	214,0	107,0	235,0	107,0	-	0
350	3	78	520	260	585	845	71,2	J3C30	575	254	214,0	107,0	235,0	107,0	ADP	10

U-sektion								J+J								
DN	PS	C	D	B	H1	H	kg	Manöverdonsutförande	H1	H2	L	L1	M	M1	ZB	P
150	16	56	269	146	454	600	22,2	J3C14	454	254	214,0	107,0	235,0	107,0	-	0
200	16	60	343	175	494	669	26,2	J3C30	494	254	214,0	107,0	235,0	107,0	-	0
200	3	60	343	175	494	669	26,2	J3C30	494	254	214,0	107,0	235,0	107,0	-	0
250	3	68	404	205	519	724	40,2	J3C30	519	254	214,0	107,0	235,0	107,0	-	0
300	3	78	484	237	544	781	60,2	J3C30	544	254	214,0	107,0	235,0	107,0	-	0
350	3	78	262	262	585	847	63,2	J3C30	575	254	214,0	107,0	235,0	107,0	ADP	10

Certifikat	Standard	Artikelnummer
2.1 Intyg om överensstämmelse	EN 10204	88039442
2.2 Funktion	EN10204/EN 12266-2 F20	88439527
2.2 Tryckprovning	EN 10204, DIN EN 12266 P10, P11, P12	88039443
3.1 Ventilhusmaterial	EN 10204	88314529
3.1 Material spjällskiva	EN 10204	88314530
3.1 Spindelmaterial		88734227
3.1 Tryckprovning	EN 10204, DIN EN 12266 P10, P11, P12	88337125
3.1 Mätning av beläggningstjocklek		88460229
3.1 Mätning av ytjämnhet (endast spjällskiva kod B)		88094384

För fler vridspjällsventiler, tillbehör och andra produkter se vårt produktsortiment och prislista. Kontakta oss gärna.

GEMÜ® UNTERNEHMENSBEREICH
VENTIL-, MESS- UND REGELSYSTEME

