

Angle Seat Globe Valve, Metal

Construction

The GEMÜ 514 pneumatically operated 2/2-way valve has a robust low maintenance aluminium piston actuator.

The valve spindle is sealed by a self-adjusting gland packing providing low maintenance and reliable valve spindle sealing even after a long service life. The wiper ring fitted in front of the gland packing protects it against contamination and damage.

Features

- Substantially reduced installation dimensions when using the body with male threads which can be removed using union nuts
- Standard floating plug on spindle ensures excellent seat sealing
- Suitable for high operating temperatures and pressures
- Control medium connection can be rotated through 360°

Advantages

- Various valve body connections: threaded sockets, threaded spigots, butt weld spigots
- Good flow capability due to angle seat design
- Extensive range of accessories
- Versions with bellows available
- Special connections and materials on request
- Optionally suitable for contact with food according to Regulation (EC) No. 1935/2004 (K-No. 2013)
- Standard gland packing suitable for vacuum up to 0.59 inHg (abs.)

Sectional drawing

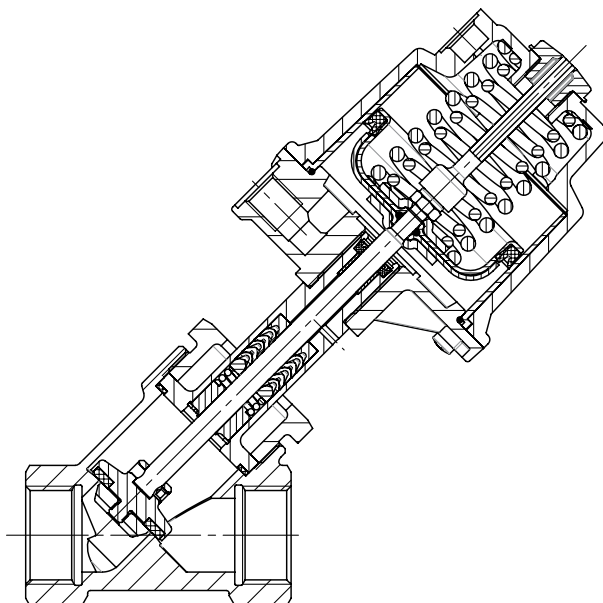

Technical data

Working medium

Corrosive, inert, gaseous and liquid media which have no negative impact on the physical and chemical properties of the body and seal material.

Max. perm. pressure of working medium see table

Medium temperature 14 °F to 356 °F

Max. permissible viscosity 600 mm²/s (cSt)

Other versions for lower/higher temperatures and viscosities on request.

Control medium

Inert gases

Max. perm. temperature of control medium: 140 °F

Filling volume Actuator size 0 and 3: 3.05 cu in
Actuator size 1 and 4: 7.63 cu in
Actuator size 2: 38.14 cu in

Flow direction

See page 5

Ambient conditions

Max. ambient temperature 140 °F

Maximum permissible seat leakage rate

Seat seal	Standard	Test procedure	Leakage rate	Test medium
PTFE	DIN EN 12266-1	P12	A	air
Metal	DIN EN 12266-1	P12	F	air

Nominal size	Max. operating pressure [psi] Normally closed					Control pressure [psi] Normally closed					Cv value [gpm]
	Actuator size 0 piston ø 1.97 in	Actuator size 3 piston ø 1.97 in	Actuator size 1 piston ø 2.76 in	Actuator size 4 piston ø 2.76 in	Actuator size 2 piston ø 4.72 in	Actuator size 0	Actuator size 3	Actuator size 1	Actuator size 4	Actuator size 2	
10	174	150	363	150	-	68 - 145	min. control pressure see diagram max. control pressure 102 psi	80 - 145	min. control pressure see diagram max. control pressure 102 psi	-	5.3
15	174	150	363	150	-	68 - 145		80 - 145		-	6.3
20	90	150	290	150	363	68 - 145		80 - 145		58 - 116	11.7
25	36	150	150	150	363	68 - 145		80 - 145		58 - 116	17.8
32	-	-	105	150	319	-		80 - 145		58 - 116	26.9
40	-	-	65	150	218	-		80 - 145		58 - 116	48
50	-	-	45	150	150	-		80 - 145		80 - 116	79.6
65	-	-	30	-	105	-		80 - 145		80 - 116	111.2
80	-	-	15	-	75	-	80 - 145	80 - 116	152.1		

Operating pressure for seal material PTFE (code 5), for seal material steel (code 10) only 60% of the values indicated above.

Cv values determined with 1 psi pressure drop across valve, body with threaded sockets DIN ISO 228. The Cv value data refers to control function 1 (NC) and the largest actuator for each nominal size. The Cv values for other product configurations (e.g. other connections or body materials) may differ.

Technical data

Nominal size	Max. operating pressure [psi] Normally open/ Double acting		Control pressure [psi] Normally open/ Double acting	
	Actuator size 1 piston ø 2.76 in	Actuator size 2 piston ø 4.72 in	Actuator size 1	Actuator size 2
10	363	-	max. 73 psi	max. 102 psi for values see diagram
15	363	-		
20	363	363	max. 102 psi	
25	363	363		
32	290	363	for values see diagram	
40	174	363		
50	120	363	max. 102 psi	
65	75	261		
80	51	150		

For max. operating pressures the pressure/temperature correlation must be observed (see table on page 3).
All pressures are gauge pressures.

Pressure / temperature correlation for angle seat globe valve bodies

Connection code	Material code	Max. allowable operating pressures in psi at temperature °F*					
		RT	212	302	392	482	572
1, 3D, 9 (up DN 50)	9	232	232	232	196	-	-
1, 9 (from DN 65)	9	150	150	150	123	-	-
1, 9, 17, 37, 60, 63, 3C, 3D	37	363	345	310	274	254	234
0, 16, 17, 37, 59, 60, 65	34	363	355	325	294	264	234
13 (DN 15 - DN 50)	34	363	342	312	287	270	249
47 (DN 15 - DN 50)	34	231	193	174	161	148	141
17, 59, 60	C2	363	307	280	260	244	231

* The valves can be used down to 14 °F RT = Room Temperature All pressures are gauge pressures.

Technical data

Operating pressure / Control pressure characteristics

Actuator size 1 Normally open (NO) Double acting (DA)

Min. control pressure dependent on operating pressure
(Flow direction: under the seat)

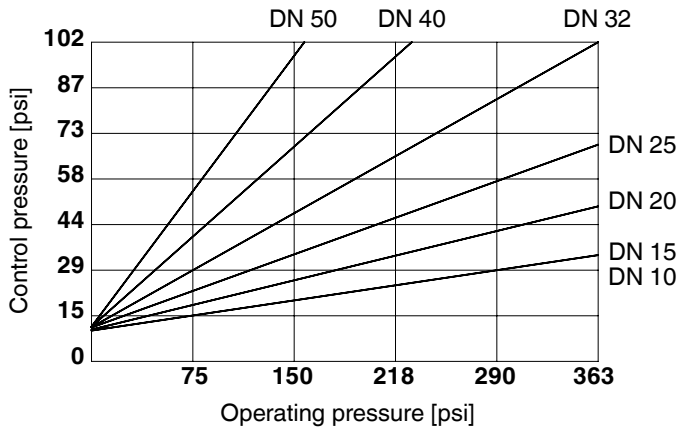

Actuator size 2 Normally open (NO) Double acting (DA)

Min. control pressure dependent on operating pressure
(Flow direction: under the seat)

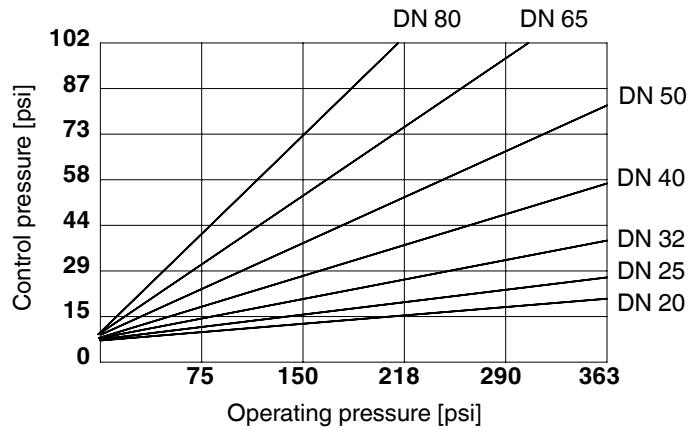

Actuator size 3 Normally closed (NC)

Min. control pressure dependent on operating pressure
(Flow direction: over the seat)

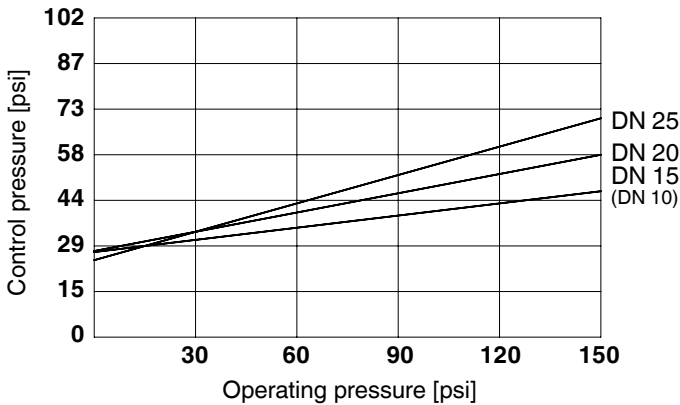

Actuator size 4 Normally closed (NC)

Min. control pressure dependent on operating pressure
(Flow direction: over the seat)

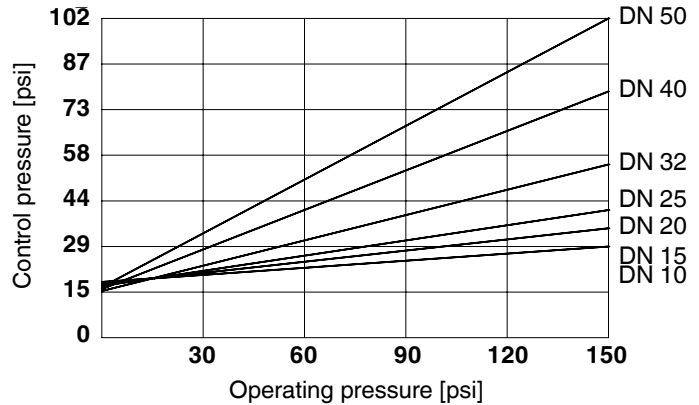

Order data

Nominal size		Code
DN 8	NPS 1/4"	8
DN 10	NPS 3/8"	10
DN 15	NPS 1/2"	15
DN 20	NPS 3/4"	20
DN 25	NPS 1"	25
DN 32	NPS 1 1/4"	32
DN 40	NPS 1 1/2"	40
DN 50	NPS 2"	50
DN 65	NPS 2 1/2"	65
DN 80	NPS 3"	80

Body configuration	Code
2/2-way body	D
Angle body only in material code 37 (DN 15 - 50)	E

Connection	Code
Butt weld spigots	
Spigots DIN	0
Spigots EN 10357 series B	16
Spigots EN 10357 series A (formerly DIN 11850 series 2) / DIN 11866 series A	17
Spigots SMS 3008	37
Spigots ASME BPE	59
Spigots ISO 1127 / EN 10357 series C / DIN 11866 series B	60
Spigots ANSI/ASME B36.19M Schedule 10s	63
Spigots ANSI/ASME B36.19M Schedule 40s	65
Threaded connections	
Threaded sockets DIN ISO 228	1
Threaded socket Rc ISO 7-1, EN 10226-2, JIS B 0203, BS 21, end-to-end dimension ETE DIN 3202-4 series M8	3C
Threaded spigots DIN ISO 228	9
Threaded sockets NPT length DIN 3202-4 series M8	3D
Flanges	
Flanges EN 1092 / PN25 /form B, length see body dimensions	13
Flanges ANSI Class 125/150 RF, length see body dimensions	47
Bodies with clamp connections available on request	

Valve body material	Code
(Rg 5) CC499K, Cast bronze	9
1.4435 (ASTM A 351 CF3M \cong 316L), Investment casting	34
1.4408, Investment casting	37
1.4435, Investment casting Material equivalency 316L	C2*
* A surface finish from the order code table "K number" must be specified for valve body material C2.	

Seat seal	Code
PTFE	5
PTFE, glass fibre reinforced	5G
Steel	10
Other seat seals on request	

Control function	Code
Normally closed (NC)	1
Normally open (NO)	2*
Double acting (DA)	3*
*not with piston \varnothing 1.97	

Actuator size	Flow	Code
Actuator 0 piston \varnothing 1.97 in	Flow under the seat	0*
Actuator 1 piston \varnothing 2.76 in	Flow under the seat	1*
Actuator 2 piston \varnothing 4.72 in	Flow under the seat	2*
Actuator 3 piston \varnothing 1.97 in	Flow over the seat	3**
Actuator 4 piston \varnothing 2.76 in	Flow over the seat	4**
* Preferred flow direction with incompressible liquid media to avoid "water hammer"		
** only control function NC		

GEMÜ 514
Actuators 0, 1, 2

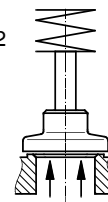

Flow
under the seat

GEMÜ 514
Actuators 3, 4

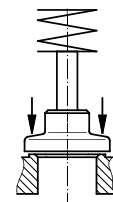

Flow
over the seat

Order data

Version	Code
Gland packing PTFE / PTFE suitable for contact with food according to EU Regulation 1935/2004	2013
Media temperature 14 to 410 °F (only with seat seal Code 5G and 10)	2023
Surface finish for valve body material C2	
Ra ≤ 0,6 µm (25 µinch) for process contact surfaces, in accordance with ASME BPE SF2 + SF3, mechanically polished internal	1903
Ra ≤ 0,8 µm (30 µinch) for process contact surfaces, in accordance with DIN 11866 H3, mechanically polished internal	1904
Ra ≤ 0,4 µm (15 µinch) for process contact surfaces, in accordance with DIN 11866 H4, ASME BPE SF1, mechanically polished internal	1909

Special version	Code
Rigid plug fixing, special version for oxygen	B
Rigid plug fixing	C
Special version for oxygen (max. temperature 140 °F, max. operating pressure 150 psi), Flow direction: under the seat	S

Order example	514	25	D	1	9	5	1	1	1903	B
Type	514									
Nominal size		25								
Body configuration (code)			D							
Connection (code)				1						
Valve body material (code)					9					
Seat seal (code)						5				
Control function (code)							1			
Actuator size (code)								1		
Version (code)									1903	
Special version (code)										B

Version for food contact
For food contact, the product must be ordered with the following ordering options:
Version code 2013
Seat seal code 5, 5G, 10
Valve body material code 34, 37, C2

Actuator dimensions / Installation dimensions - Valve with 2/2-way body [inch]

Actuator dimensions

Actuator size	ø B [in]	M	A2 [in]	G
0 + 3	2.8	M 16x1	-	G 1/4
1 + 4	3.78	M 16x1	3.37	G 1/4
2	6.46	M 22x1.5	4.84	G 1/4

Installation dimensions / Weight

DN	Wrench size SW1 [mm]	Actuator size 0 and 3		Actuator size 1 and 4		Actuator size 2	
		CT/LA [in]	Weight [lbs]	CT/LA [in]	Weight [lbs]	CT/LA [in]	Weight [lbs]
8	36	5.91	-	6.34	-	-	-
10	36	5.91	2.0	6.34	3.1	-	-
15	36	6.02	2.0	6.46	3.1	-	-
20	41	6.42	2.4	6.85	3.5	9.49	-
25	46	6.42	2.9	6.85	4.0	9.49	-
32	55	-	-	7.17	5.3	9.80	10.1
40	60	-	-	7.36	5.9	10.00	12.1
50	75	-	-	7.68	7.5	10.31	14.1
65	75	-	-	-	-	10.83	18.7
80	75	-	-	-	-	11.50	21.2

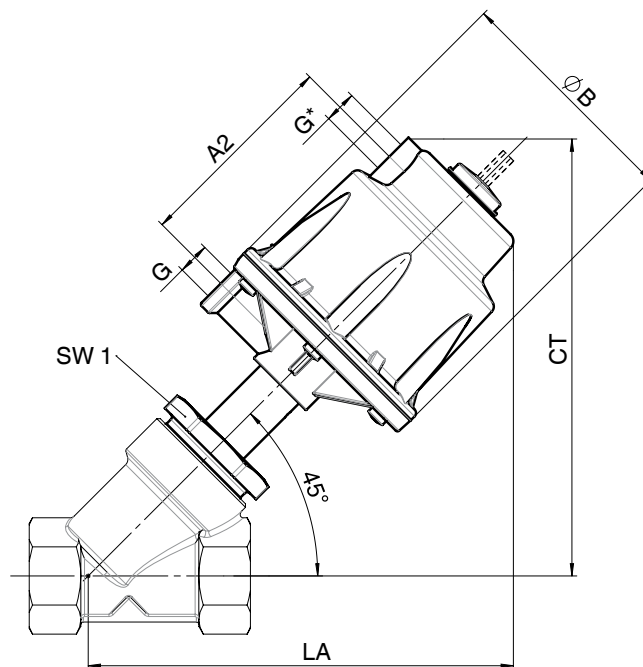

* Connection only for actuator sizes 1 and 2; c.f. 2 and 3

Actuator dimensions / Installation dimensions - Valve with angle body [inch]

Actuator dimensions

Actuator size	ø B [in]	M	A2 [in]	G
0 + 3	2.8	M 16x1	-	G 1/4
1 + 4	3.78	M 16x1	3.37	G 1/4
2	6.46	M 22x1.5	4.84	G 1/4

Installation dimensions / Weight

DN	Wrench size SW1 [mm]	Actuator size 0 and 3		Actuator size 1 and 4		Actuator size 2	
		CT [in]	Weight [lbs]	CT [in]	Weight [lbs]	CT [in]	Weight [lbs]
15	36	7.05	2.0	7.44	3.1	-	-
20	41	7.17	2.4	7.56	3.5	10.28	-
25	46	7.32	2.9	7.72	4.0	10.43	-
32	55	-	-	7.83	5.3	10.55	10.1
40	60	-	-	8.03	5.9	10.75	12.1
50	75	-	-	8.31	7.5	11.02	14.1

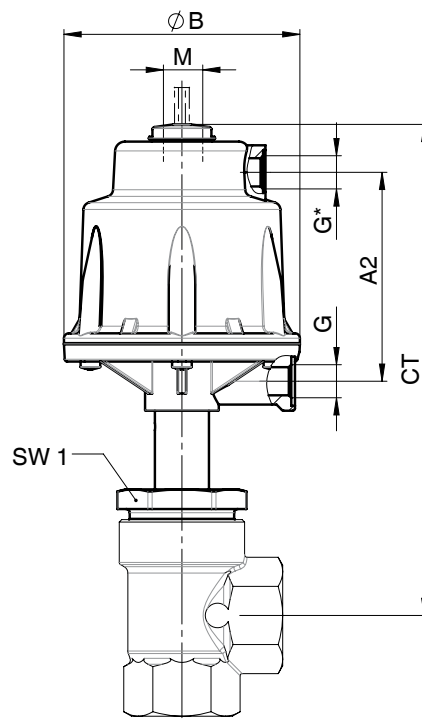

* Connection only for actuator sizes 1 and 2; c.f. 2 and 3

Body dimensions [inch]

Butt weld spigots, connection code 0, 16, 17, 37, 60 Valve body material: 1.4435 (code 34), 1.4408 (code 37)

DN	Material code 34		Material code 37		Connection code									
	L	LB	L	LB	0		16		17		37		60	
					ø d	s	ø d	s	ø d	s	ø d	s	ø d	s
10	4.13	1.40	-	-	-	-	0.472	0.039	0.512	0.059	-	-	0.677	0.063
15	4.13	1.40	3.94	1.30	0.709	0.059	0.709	0.039	0.748	0.059	-	-	0.839	0.063
20	4.72	1.54	4.25	1.30	0.866	0.059	0.866	0.039	0.906	0.059	-	-	1.059	0.063
25	4.92	1.52	4.41	1.26	1.102	0.059	1.102	0.039	1.142	0.059	0.984	0.047	1.327	0.079
32	6.10	1.89	5.39	1.54	-	-	1.339	0.039	1.378	0.059	-	-	1.669	0.079
40	6.30	1.85	5.75	1.57	1.575	0.059	1.575	0.039	1.614	0.059	1.496	0.047	1.902	0.079
50	7.09	1.89	6.30	1.50	2.047	0.059	2.047	0.039	2.087	0.059	2.008	0.047	2.374	0.079
65	-	-	11.42	3.78	-	-	-	-	2.756	0.079	2.500	0.063	2.996	0.079
80	-	-	12.20	3.74	-	-	-	-	3.346	0.079	2.996	0.063	3.5	0.091

For materials see overview on last page

Butt weld spigots, connection code 59, 63, 65 Valve body material: 1.4435 (code 34), 1.4408 (code 37)

DN	Material code 34		Material code 37		Connection code					
	L	LB	L	LB	59		63		65	
					ø d	s	ø d	s	ø d	s
10	4.13	1.40	-	-	-	-	-	-	-	-
15	4.13	1.40	3.94	1.30	0.500	0.065	0.839	0.083	0.839	0.109
20	4.72	1.54	4.25	1.30	0.750	0.065	1.051	0.083	1.051	0.113
25	4.92	1.52	4.41	1.26	1.000	0.065	1.315	0.109	1.315	0.153
32	6.10	1.89	5.39	1.54	-	-	-	-	1.669	0.140
40	6.30	1.85	5.75	1.57	1.500	0.065	1.902	0.109	1.902	0.145
50	7.09	1.89	6.30	1.50	2.000	0.065	2.374	0.109	2.374	0.154
65	-	-	11.42	3.78	2.500	0.065	2.874	0.120	-	-
80	-	-	12.20	3.74	3.000	0.065	3.500	0.120	-	-

For materials see overview on last page

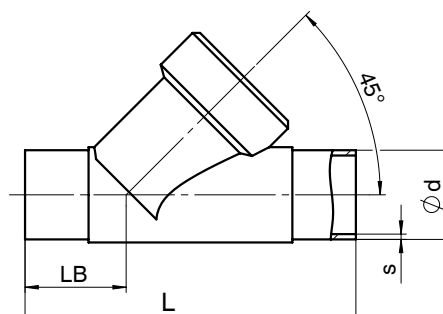

Body dimensions [inch]

Butt weld spigots, connection code 17, 59, 60 Valve body material: 1.4435 (code C2)

			Connection code					
			17		60		59	
DN	L	LB	$\varnothing d$	s	$\varnothing d$	s	$\varnothing d$	s
8	4.13*	1.40*	-	-	0.531	0.063	-	-
10	4.13	1.40	0.512	0.059	0.677	0.063	-	-
15	4.13	1.40	0.748	0.059	0.839	0.063	0.500	0.065
20	4.72	1.54	0.906	0.059	1.059	0.063	0.750	0.065
25	4.92	1.56	1.142	0.059	1.327	0.079	1.000	0.065
32	6.10	1.89	1.378	0.059	1.669	0.079	-	-
40	6.30	1.85	1.614	0.059	1.902	0.079	1.500	0.065
50	7.09	1.89	2.087	0.059	2.374	0.079	2.000	0.065
65	11.42	3.78	2.756	0.079	2.996	0.079	2.500	0.065
80	12.20	3.74	3.346	0.079	3.500	0.091	3.000	0.065

* Connection code 1A: L = 3.94, LB = 1.32

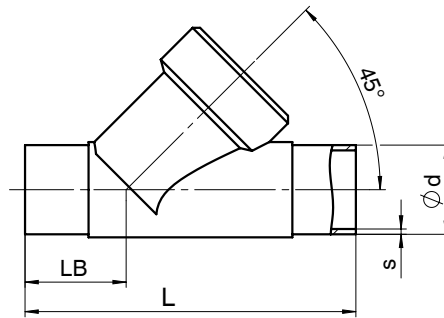

Body dimensions

Threaded sockets DIN, connection code 1 Valve body material: Cast bronze (code 9), 1.4408 (code 37)

DN	L [in]	LB [in]	R	t [in]	SW2 [mm]	
10	2.56	0.65	G 3/8	0.45	27	hexagonal
15	2.56	0.65	G 1/2	0.59	27	hexagonal
20	2.95	0.69	G 3/4	0.64	32	hexagonal
25	3.54	0.94	G 1	0.75	41	hexagonal
32	4.33	1.30	G 1 1/4	0.84	50	octagonal
40	4.72	1.18	G 1 1/2	0.84	55	octagonal
50	5.91	1.57	G 2	1.01	70	octagonal
65	7.48	1.81	G 2 1/2	1.19	85	octagonal
80	8.66	1.97	G 3	1.31	100	octagonal

For materials see overview on last page

Threaded sockets NPT, BS 21 Rc, connection code 3C, 3D Valve body material: 1.4408 (code 37)

DN	L [in]	LB [in]	SW2 [mm]	Connection code				
				3C		3D		
				R	t [in]	R	t [in]	
15	2.56	0.65	27	hexagonal	Rc 1/2	0.59	1/2" NPT	0.54
20	2.95	0.69	32	hexagonal	Rc 3/4	0.64	3/4" NPT	0.56
25	3.54	0.94	41	hexagonal	Rc 1	0.75	1" NPT	0.67
32	4.33	1.30	50	octagonal	Rc 1 1/4	0.84	1 1/4" NPT	0.69
40	4.72	1.18	55	octagonal	Rc 1 1/2	0.84	1 1/2" NPT	0.68
50	5.91	1.57	70	octagonal	Rc 2	1.01	2" NPT	0.70
65	7.48	1.81	85	octagonal	Rc 2 1/2	1.19	2 1/2" NPT	0.93
80	8.66	1.97	100	octagonal	Rc 3	1.31	3" NPT	1.02

For materials see overview on last page.

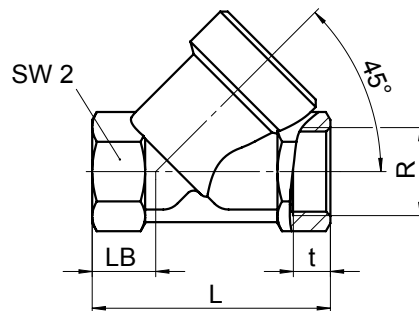

Threaded sockets DIN, connection code 1, 3D / Angle body Valve body material: 1.4408 (code 37)

DN	SW2 [mm]	LE [in]	H2 [in]	Connection code 1		Connection code 3D	
				R	t [in]	R	t [in]
15	27	1.18	1.18	G 1/2	0.59	1/2" NPT	0.54
20	32	1.38	1.48	G 3/4	0.64	3/4" NPT	0.56
25	41	1.61	1.61	G 1	0.75	1" NPT	0.67
32	50	1.97	1.89	G 1 1/4	0.84	1 1/4" NPT	0.69
40	55	1.97	2.17	G 1 1/2	0.84	1 1/2" NPT	0.68
50	70	2.36	2.44	G 2	1.01	2" NPT	0.70

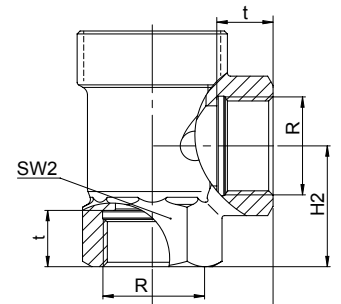

Body dimensions [inch]

Threaded spigots, connection code 9 Valve body material: Cast bronze (code 9), 1.4408 (code 37)

DN	L	LB	t	R
15	3.54	0.98	0.47	G 3/4
20	4.33	1.18	0.59	G 1
25	4.65	1.18	0.59	G 1 1/4
32	5.12	1.50	0.51	G 1 1/2
40	5.51	1.38	0.51	G 1 3/4
50	6.89	1.97	0.59	G 2 3/8
65	8.50	2.05	0.59	G 3
80	10.00	2.52	0.71	G 3 1/2

For materials see overview on last page

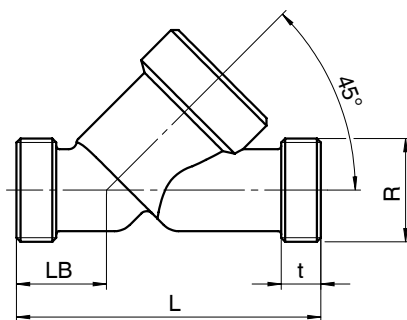

Flanges, connection code 13, 47 Valve body material: 1.4435 (code 34)

DN	FTF	LB	Connection code 13				Connection code 47			
			ø D	ø L	ø k	Number of bolts	ø D	ø L	ø k	Number of bolts
15	8.27	2.83	3.74	0.55	2.56	4	3.50	0.62	2.38	4
20	11.02	3.07	4.13	0.55	2.95	4	3.88	0.62	2.75	4
25	11.02	3.03	4.53	0.55	3.35	4	4.25	0.62	3.12	4
32	12.20	3.50	5.51	0.71	3.94	4	4.62	0.62	3.50	4
40	12.60	3.58	5.91	0.71	4.33	4	5.00	0.62	3.88	4
50	12.99	3.74	6.50	0.71	4.92	4	6.00	0.75	4.75	4

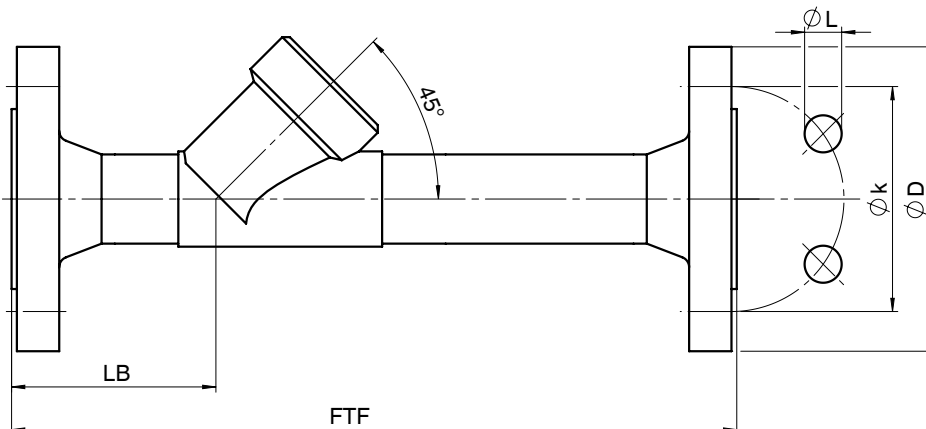

Overview of metal bodies for GEMÜ 514															
	Spigots														
Connection code	0	16	17			37		59			60			63	65
Material code	34	34	34	37	C2	34	37	34	37	C2	34	37	C2	37	34
DN 8	-	-	-	-	-	-	-	-	-	-	-	-	X	-	-
DN 10	-	X	X	-	X	-	-	-	-	-	X	-	X	-	-
DN 15	X	X	X	X	X	-	-	X	-	X	X	X	X	X	X
DN 20	X	X	X	X	X	-	-	X	-	X	X	X	X	X	X
DN 25	X	X	X	X	X	X	-	X	-	X	X	X	X	X	X
DN 32	-	X	X	X	X	-	-	-	-	-	X	X	X	-	X
DN 40	X	X	X	X	X	X	-	X	-	X	X	X	X	X	X
DN 50	X	X	X	X	X	X	-	X	-	X	X	X	X	X	X
DN 65	-	-	-	X	X	-	X	-	X	X	-	X	X	X	-
DN 80	-	-	-	X	X	-	X	-	X	X	-	X	X	X	-

All rights including copyright and industrial property rights are expressly reserved.

Overview of metal bodies for GEMÜ 514											
	Threaded connections									Flanges	
Connection code	1			3C	9		3D			13	47
Material code	9	37	37	37	9	37	9	37	37	34	34
Body configuration		2/2-way body	Angle body					2/2-way body	Angle body		
DN 10	-	X	-	-	-	-	-	-	-	-	-
DN 15	X	X	X	X	X	X	X	X	X	X	X
DN 20	X	X	X	X	X	X	X	X	X	X	X
DN 25	X	X	X	X	X	X	X	X	X	X	X
DN 32	X	X	X	X	-	X	X	X	X	X	X
DN 40	X	X	X	X	X	X	X	X	X	X	X
DN 50	X	X	X	X	X	X	X	X	X	X	X
DN 65	X	X	-	X	X	X	-	X	-	-	-
DN 80	X	X	-	X	X	X	-	X	-	-	-

Should there be any doubts or misunderstandings, the German version of this data sheet is the authoritative document!

For further globe valves, accessories and other products, please see our Product Range catalogue and Price List.
Contact GEMÜ.

GEMÜ VALVES, MEASUREMENT AND CONTROL SYSTEMS

