

GEMÜ 529 eSyLite

Motorized angle seat globe valve



Features

- Motorized linear actuator for Open/Close applications
- Self-locking spindle actuator
- Safety shut-down integrated
- Standard optical position indicator and manual override
- Integrated emergency power supply module (optional)
- Electrical position indicator GEMÜ 1215 (optional)

Description

The GEMÜ 529 eSyLite 2/2-way angle seat globe valve is motorized. It is available as an Open/Close version. The valve spindle is sealed by a self-adjusting gland packing providing low-maintenance and reliable valve spindle sealing even after a long service life. A wiper ring fitted in front of the gland packing protects the seal against contamination and damage. An integrated optical position indicator is standard. The self-locking actuator holds its position in a stable manner in the event of power supply failure.

Technical specifications

- **Media temperature:** -10 to 180 °C
- **Ambient temperature:** -10 to 60 °C
- **Operating pressure :** 0 to 25 bar
- **Nominal sizes:** DN 15 to 80
- **Body configurations:** 2/2-way body | Angle valve body
- **Connection types:** Clamp | Flange | Spigot | Threaded connection
- **Connection standards:** ANSI | ASME | BS | DIN | EN | ISO | NPT | SMS
- **Body materials:** 1.4408, investment casting material | 1.4435, investment casting material | CC499K, cast bronze material
- **Seat seal materials:** PTFE | PTFE, reinforced
- **Supply voltage:** 24 V DC
- **Actuating speed:** max. 3 mm/s
- **Protection class:** IP65
- **Conformities:** FDA | Regulation (EC) No. 1935/2004 | TA Luft (German Clean Air Act)

Technical data depends on the respective configuration



Product description

Construction

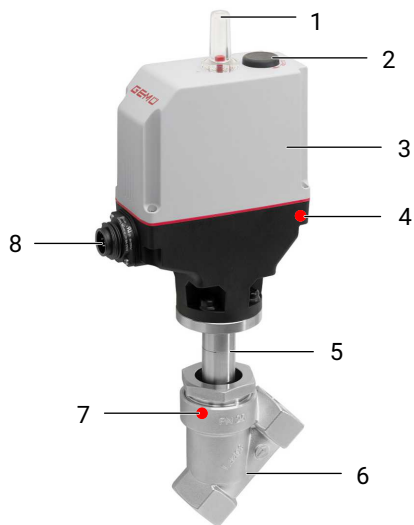

Item	Name	Materials
1	Optical position indicator	PA 12
2	Manual override	
3	Motorized actuator	Reinforced polyamide
4	CONEXO actuator RFID chip	
5	Distance piece with leak detection hole	1.4305 / 1.4408
6	Valve body	1.4435, investment casting 1.4408, investment casting CC499K, cast bronze
7	CONEXO body RFID chip	
8	Electrical connection	

GEMÜ CONEXO

The interaction of valve components that are equipped with RFID chips and an associated IT infrastructure actively increase process reliability.



Thanks to serialization, every valve and every relevant valve component such as the body, actuator or diaphragm, and even automation components, can be clearly traced and read using the CONEXO pen RFID reader. The CONEXO app, which can be installed on mobile devices, not only facilitates and improves the "installation qualification" process, but also makes the maintenance process much more transparent and easier to document. The app actively guides the maintenance technician through the maintenance schedule and directly provides him with all the information assigned to the valve, such as test reports, testing documentation and maintenance histories. The CONEXO portal acts as a central element, helping to collect, manage and process all data.

For further information on GEMÜ CONEXO please visit:

www.gemu-group.com/conexo

Ordering

GEMÜ Conexo must be ordered separately with the ordering option "CONEXO".

Availabilities

Availability of valve bodies

Spigot

DN	Connection type code ¹⁾														
	0	16	17			37		59			60			63	65
	Material code ²⁾														
	34	34	34	37	C2	34	37	34	37	C2	34	37	C2	37	34
15	X	X	X	X	X	-	-	X	-	X	X	X	X	X	X
20	X	X	X	X	X	-	-	X	-	X	X	X	X	X	X
25	X	X	X	X	X	X	-	X	-	X	X	X	X	X	X
32	-	X	X	X	X	-	-	-	-	-	X	X	X	-	X
40	X	X	X	X	X	X	-	X	-	X	X	X	X	X	X
50	X	X	X	X	X	X	-	X	-	X	X	X	X	X	X
65	-	-	-	X	X	-	X	-	X	X	-	X	X	X	-
80	-	-	-	X	X	-	X	-	X	X	-	X	X	X	-

X = Standard

1) Connection type

Code 0: Spigot DIN

Code 16: Spigot EN 10357 series B, formerly DIN 11850 series 1

Code 17: Spigot EN 10357 series A / DIN 11866 series A formerly DIN 11850 series 2

Code 37: Spigot SMS 3008

Code 59: Spigot ASME BPE/DIN 11866 series C

Code 60: Spigot ISO 1127/EN 10357 series C/DIN 11866 series B

Code 63: Spigot ANSI/ASME B36.19M schedule 10s

Code 65: Spigot ANSI/ASME B36.19M schedule 40s

2) Valve body material

Code 34: 1.4435, investment casting

Code 37: 1.4408, investment casting

Code C2: 1.4435, investment casting

Threaded connection

Body configuration code D ¹⁾

DN	Connection type code ²⁾						
	1		3C	3D		9	
	Material code ³⁾						
	9	37	37	9	37	9	37
15	X	X	X	X	X	X	X
20	X	X	X	X	X	X	X
25	X	X	X	X	X	X	X
32	X	X	X	X	X	-	X
40	X	X	X	X	X	X	X
50	X	X	X	X	X	X	X
65	X	X	X	-	X	X	X
80	X	X	X	-	X	X	X

Body configuration code E ¹⁾

DN	Connection type code ²⁾	
	1	3D
	Material code ³⁾	
	37	37
15	X	X
20	X	X
25	X	X
32	X	X
40	X	X
50	X	X

X = Standard

1) Body configuration

Code D: 2/2-way body
Code E: Angle valve body

2) Connection type

Code 1: Threaded socket DIN ISO 228
Code 3C: Threaded socket Rc ISO 7-1, EN 10226-2, JIS B 0203, BS 21, end-to-end dimension ETE DIN 3202-4 series M8
Code 3D: Threaded socket NPT, end-to-end dimension ETE DIN 3202-4 series M8
Code 9: Threaded spigot DIN ISO 228

3) Valve body material

Code 9: CC499K, cast bronze
Code 37: 1.4408, investment casting

Flange

DN	Connection type code ¹⁾	
	13	47
	Material code ²⁾	
	34	34
15	X	X
20	X	X
25	X	X
32	X	X
40	X	X
50	X	X

X = Standard

1) **Connection type**

Code 13: Flange EN 1092, PN 25, form B

Code 47: Flange ANSI Class 150 RF

2) **Valve body material**

Code 34: 1.4435, investment casting

Clamp

DN	Connection type code ¹⁾			
	80	82	86	88
	Material code ²⁾			
	34	34	34	34
15	X	X	X	X
20	X	X	X	X
25	X	X	X	X
32	-	X	X	-
40	X	X	X	X
50	X	X	X	X

X = Standard

1) **Connection type**

Code 80: Clamp ASME BPE, face-to-face dimension FTF ASME BPE

Code 82: Clamp DIN 32676 series B, face-to-face dimension FTF EN 558 series 1

Code 86: Clamp DIN 32676 series A, face-to-face dimension FTF EN 558 series 1

Code 88: Clamp ASME BPE, for pipe ASME BPE, face-to-face dimension FTF EN 558 series 1

2) **Valve body material**

Code 34: 1.4435, investment casting

Product conformity

	Approved designs		
	Valve body material	Seat seal	Type of design
Food			
FDA Regulation (EC) 1935/2004 Regulation (EC) 10/2011	1.4435, investment casting (code 34) 1.4408, investment casting (code 37) 1.4435, investment casting (code C2)	PTFE (code 5) PTFE, glass fibre reinforced (code 5G) 1.4404 (code 10)	Spindle seal PTFE-PTFE (code 2013)

Order data

The order data provide an overview of standard configurations.

Please check the availability before ordering. Other configurations available on request.

Order codes

1 Type	Code
Angle seat globe valve, electrically operated eSyLite	529

2 DN	Code
DN 15	15
DN 20	20
DN 25	25
DN 32	32
DN 40	40
DN 50	50
DN 65	65
DN 80	80

3 Body configuration	Code
2/2-way body	D
Angle valve body	E

4 Connection type	Code
Spigot	
Spigot DIN	0
Spigot EN 10357 series B, formerly DIN 11850 series 1	16
Spigot EN 10357 series A / DIN 11866 series A formerly DIN 11850 series 2	17
Spigot SMS 3008	37
Spigot ASME BPE/DIN 11866 series C	59
Spigot ISO 1127/EN 10357 series C/DIN 11866 series B	60
Spigot ANSI/ASME B36.19M schedule 10s	63
Spigot ANSI/ASME B36.19M schedule 40s	65
Threaded connection	
Threaded socket DIN ISO 228	1
Threaded socket Rc ISO 7-1, EN 10226-2, JIS B 0203, BS 21, end-to-end dimension ETE DIN 3202-4 series M8	3C
Threaded socket NPT, end-to-end dimension ETE DIN 3202-4 series M8	3D
Threaded spigot DIN ISO 228	9
Flange	
Flange EN 1092, PN 25, form B	13
Flange ANSI Class 150 RF	47
Clamp	
Clamp ASME BPE, face-to-face dimension FTF ASME BPE	80
Clamp DIN 32676 series B, face-to-face dimension FTF EN 558 series 1	82

4 Connection type	Code
Clamp DIN 32676 series A, face-to-face dimension FTF EN 558 series 1	86
Clamp ASME BPE, for pipe ASME BPE, face-to-face dimension FTF EN 558 series 1	88

5 Valve body material	Code
Investment casting material	
1.4435, investment casting	34
1.4408, investment casting	37
1.4435, investment casting	C2
Cast bronze	
CC499K, cast bronze	9

6 Seat seal	Code
PTFE	5
PTFE, glass fibre reinforced	5G

7 Voltage/frequency	Code
24 V DC	C1

8 Control module	Code
ON/OFF actuator (economy)	A0
ON/OFF actuator (economy) emergency power supply module (NC)	A1
ON/OFF actuator (economy) emergency power supply module (NO)	A2
OPEN/CLOSE control with mounted GEMU 1215 position indicator	Z0
OPEN/CLOSE control with mounted GEMÜ 1215 position indicator emergency power supply module (NC)	Z1
OPEN/CLOSE control with mounted GEMÜ 1215 position indicator emergency power supply module (NO)	Z2

9 Actuator version	Code
Actuator size 1	1A
Actuator size 3	3A

10 Type of design	Code
Spindle seal PTFE-PTFE	2013

12 CONEXO	Code
Without	
Integrated RFID chip for electronic identification and traceability	C

Order example

Ordering option	Code	Description
1 Type	529	Angle seat globe valve, electrically operated eSyLite
2 DN	25	DN 25
3 Body configuration	D	2/2-way body
4 Connection type	1	Threaded socket DIN ISO 228
5 Valve body material	37	1.4408, investment casting
6 Seat seal	5	PTFE
7 Voltage/frequency	C1	24 V DC
8 Control module	A0	ON/OFF actuator (economy)
9 Actuator version	1A	Actuator size 1
10 Type of design		
11 Special version		
12 CONEXO		Without

Technical data

Medium

Working medium: Corrosive, inert, gaseous and liquid media which have no negative impact on the physical and chemical properties of the body and seal material.

Max. permissible viscosity: 600 mm²/s
Other versions for lower / higher temperatures and higher viscosities on request.

Temperature

Media temperature: -10 – 180 °C

Ambient temperature: -10 – 60 °C
* depending on version and/or operating parameters (see chapter Duty cycle and service life)
If the emergency power module is used (control module code A1, A2, Z1, Z2), the maximum ambient temperature is reduced to 40 °C.

Storage temperature: -25 – 60 °C

Pressure

Operating pressure:

DN	Actuator version 1A	Actuator version 3A
15	25	-
20	25	-
25	25	-
32	22	25
40	13	25
50	8	17

All pressures are gauge pressures.
For max. operating pressures the pressure / temperature correlation must be observed.
Higher operating pressures on request
DN 65 and DN 80 available on request

Leakage rate: Leakage rate A to P11/P12 EN 12266-1

Pressure/temperature correlation:

Connection types code ¹⁾	Material code ²⁾	Max. allowable operating pressures in bar at temperature in °C			
		RT	100	150	200
1, 9, 17, 37, 60, 63, 3C, 3D	37	25.0	23.8	21.4	18.9
0, 16, 17, 37, 59, 60, 65	34	25.0	24.5	22.4	20.3
13 (DN 15 - DN 50)	34	25.0	23.6	21.5	19.8
80, 88 (DN 15 - DN 40)	34	25.0	21.2	19.3*	-
80, 88 (DN 50 - DN 80)	34	16.0	16.0	16.0*	-
82 (DN 15 - DN 32)	34	25.0	21.2	19.3*	-
82 (DN 40 - DN 65)	34	16.0	16.0	16.0*	-
86 (DN 15 - DN 40)	34	25.0	21.2	19.3*	-
86 (DN 50 - DN 65)	34	16.0	16.0	16.0*	-
47 (DN 15 - DN 50)	34	15.9	13.3	12.0	11.1
17, 59, 60	C2	25.0	21.2	19.3	17.9

* max. temperature 140 °C

1) **Connection type**

- Code 0: Spigot DIN
- Code 1: Threaded socket DIN ISO 228
- Code 3C: Threaded socket Rc ISO 7-1, EN 10226-2, JIS B 0203, BS 21, end-to-end dimension ETE DIN 3202-4 series M8
- Code 3D: Threaded socket NPT, end-to-end dimension ETE DIN 3202-4 series M8
- Code 9: Threaded spigot DIN ISO 228
- Code 13: Flange EN 1092, PN 25, form B
- Code 16: Spigot EN 10357 series B, formerly DIN 11850 series 1
- Code 17: Spigot EN 10357 series A / DIN 11866 series A formerly DIN 11850 series 2
- Code 37: Spigot SMS 3008
- Code 47: Flange ANSI Class 150 RF
- Code 59: Spigot ASME BPE/DIN 11866 series C
- Code 60: Spigot ISO 1127/EN 10357 series C/DIN 11866 series B
- Code 63: Spigot ANSI/ASME B36.19M schedule 10s
- Code 65: Spigot ANSI/ASME B36.19M schedule 40s
- Code 80: Clamp ASME BPE, face-to-face dimension FTF ASME BPE
- Code 82: Clamp DIN 32676 series B, face-to-face dimension FTF EN 558 series 1
- Code 86: Clamp DIN 32676 series A, face-to-face dimension FTF EN 558 series 1
- Code 88: Clamp ASME BPE, for pipe ASME BPE, face-to-face dimension FTF EN 558 series 1

2) **Valve body material**

- Code 34: 1.4435, investment casting
- Code 37: 1.4408, investment casting
- Code C2: 1.4435, investment casting

Product conformity

Machinery Directive: 2006/42/EC

Pressure Equipment Directive: 2014/68/EU

Food: Regulation (EC) No. 1935/2004*
Regulation (EC) No. 10/2011*
FDA*
* depending on version and/or operating parameters

EMC Directive: 2014/30/EU

RoHS Directive: 2011/65/EU

Mechanical data

Protection class: IP 65 acc. to EN 60529

Actuating speed: Max. 3 mm/s

Installation position: Optional

Weight: Actuator

DN	Actuator size	Weight without valve body
15	1A	1.20
20	1A	1.21
25	1A	1.22
32	1A	1.48
40	1A	1.75
40	3A	2.25
50	1A	2.00
50	3A	2.50
65	3A	-
80	3A	-

Weights in kg
DN 65 and DN 80 available on request

Valve body

DN	Spigot K514	Threaded socket	Threaded spigot	Flange K514	Clamp
	Connection types code				
	0, 16, 17, 37, 59, 60	1, 3D, 3C	9	13, 47	80, 82, 86, 88
15	0.24	0.35	0.31	1.80	0.37
20	0.50	0.35	0.50	2.50	0.63
25	0.50	0.35	0.65	3.10	0.63
32	0.90	0.75	1.00	4.60	1.08
40	1.10	0.98	1.30	5.10	1.28
50	1.80	1.70	1.80	7.20	2.07
65	3.40	3.20	3.40	-	3.69
80	4.20	4.10	4.40	-	4.60

Weights in kg

Mechanical environmental conditions: Class 4M8 acc. to EN 60721-3-4:1998

Vibration: 5g acc. to IEC 60068-2-6 Test Fc

Shock: 25g acc. to 60068-2-27 Test Ea

Actuator duty cycle and service life

Service life:	Class A acc. to EN 15714-2 Minimum 100,000 switching cycles at room temperature and permissible duty cycle.
Duty cycle:	max. 30% duty

Electrical data

Supply voltage:	24 V DC Tolerance $\pm 10\%$
Operating time:	MG 10: 2.5 s MG 20: 3.5 s MG 25: 4.0 s MG 40: 4.5 s MG 50: 7.0 s
Close tight current / rated current:	MG 10: 0.5 A MG 20: 1.4 A MG 25: 1.3 A MG 40: 2.3 A MG 50: 2.3 A
Starting current / maximum current:	MG 10: approx. 2.4 A MG 20: approx. 2.4 A MG 25: approx. 2.4 A MG 40: approx. 4.5 A MG 50: approx. 4.5 A
Standby current consumption:	approx. 10 mA

Digital input signals

Input voltage:	max. 30 V DC $\geq 56\text{ k}\Omega$
High level:	$\geq 18\text{ V DC}$
Low level:	$\leq 5\text{ V DC}$
Minimum actuation duration:	600 ms
Input current:	$< 0.6\text{ mA}$

Emergency power supply module

Charging current:	MG 10, MG 20, MG 25: max. 0.16 A MG 40: 0.32 A MG 50: not available
Charging time:	approx. 13 min
Service life:	Guide value at 25 °C ambient temperature, approx. 3 years

Electrical connection

Position of the connectors

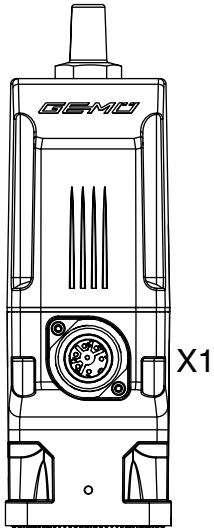

Electrical connection

Connection X1

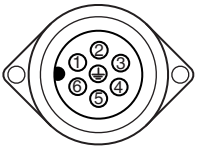

7-pin plug, Binder, type 693

Pin	Signal name
1	24 V supply voltage
2	GND
3	Digital input OPEN
4	Digital input CLOSED
5	n.c.
6	n.c.
7	n.c.

Preferred direction if both digital inputs are present for device version 00 (see operating instructions – Product label)	
Control module ordering option	Preferred direction
A0, Y0, Z0	OPEN
A1, Y1, Z1	CLOSED
A2, Y1, Z2	OPEN

Preferred direction if both digital inputs are present for device version 01 (see operating instructions – Product label)	
Control module ordering option	Preferred direction
A0, Y0, Z0	OPEN
A1, Y1, Z1	OPEN

Preferred direction if both digital inputs are present
for device version 01
(see operating instructions – Product label)

A2, Y2, Z2 CLOSED

Dimensions

Installation and actuator dimensions - Valve with 2/2-way body without position indicator

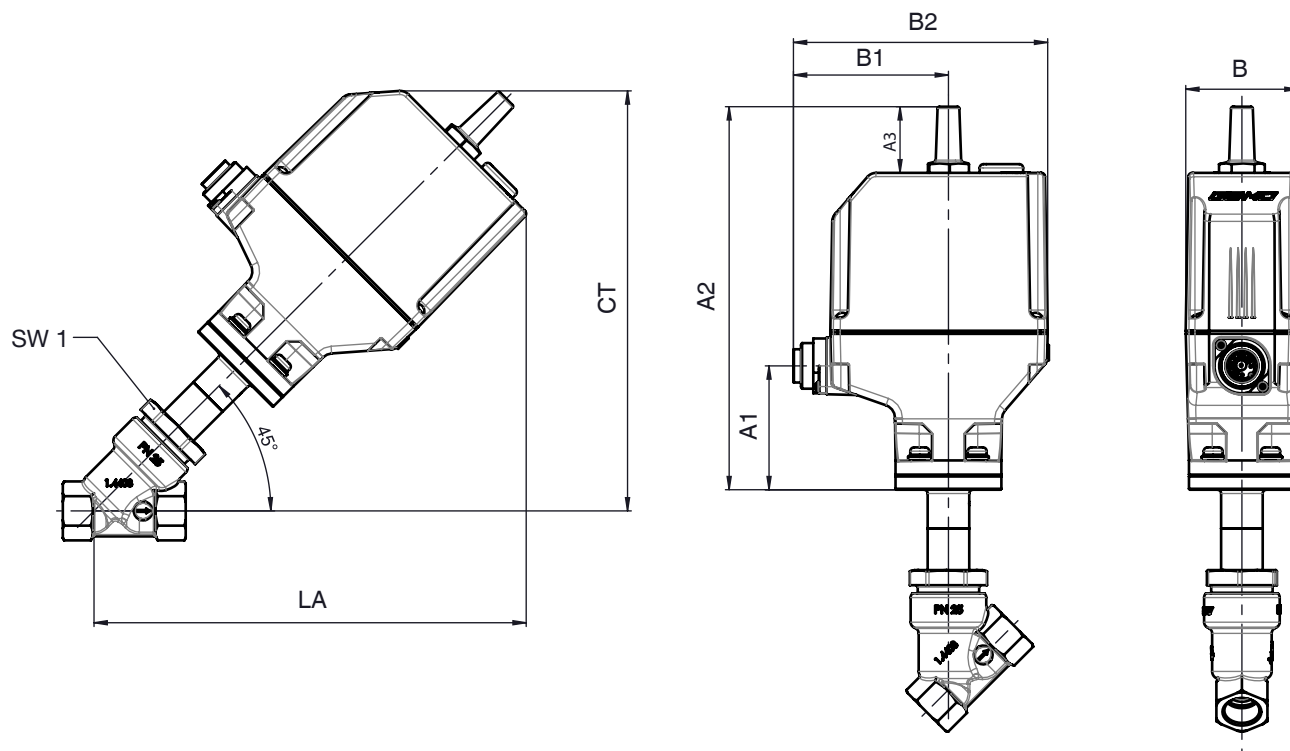

DN	Actuator version	A1	A2	A3	B	B1	B2	CT	LA	SW1
15	1A	65.5	203.0	35.0	59.5	82.0	134.5	222.0	229.0	36
20	1A	65.5	203.0	35.0	59.5	82.0	134.5	228.0	234.0	41
25	1A	65.5	203.0	35.0	59.5	82.0	134.5	232.0	239.0	46
32	1A	65.5	203.0	35.0	59.5	82.0	134.5	239.0	246.0	55
40	1A	65.5	203.0	35.0	59.5	82.0	134.5	251.0	257.0	60
40	3A	72.0	232.0	50.0	80.0	94.5	167.0	273.0	281.0	60
50	1A	65.5	203.0	35.0	59.5	82.0	134.5	259.0	265.0	75
50	3A	72.0	232.0	50.0	80.0	94.5	167.0	281.0	289.0	75
65	3A	72.0	232.0	50.0	80.0	94.5	167.0	295.0	304.0	75
80	3A	72.0	232.0	50.0	80.0	94.5	167.0	310.0	318.0	75

Dimensions in mm

Installation and actuator dimensions - Valve with 2/2-way body with position indicator

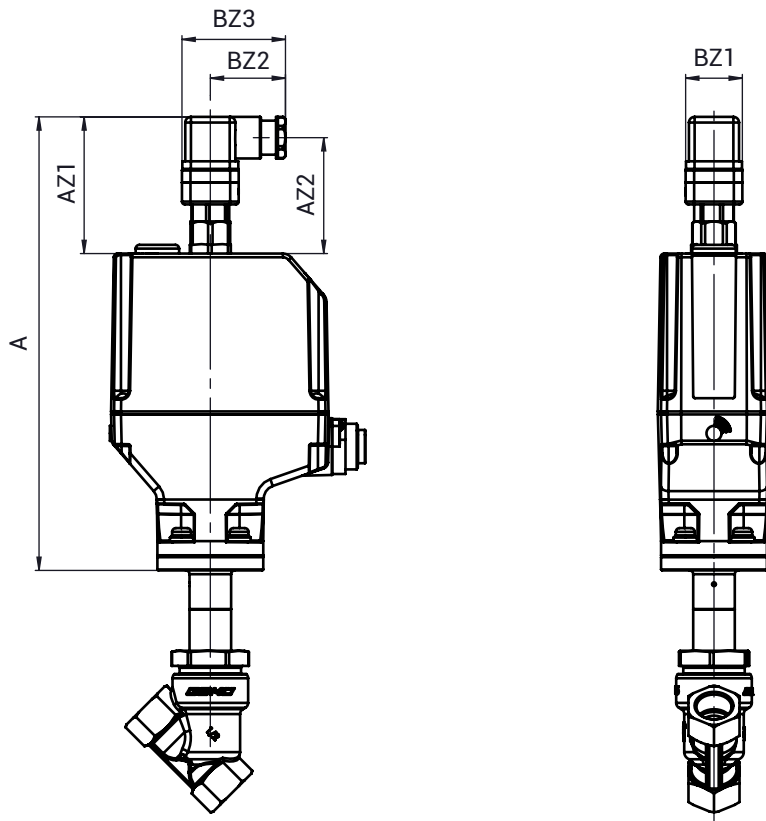

Actuator version	A	AZ1	AZ2	BZ1	BZ2	BZ3
1A	240.0	72.0	61.0	30.0	40.0	55.0
3A	269.0	72.0	61.0	30.0	40.0	55.0

Dimensions in mm

Installation and actuator dimensions - Valve with angle body

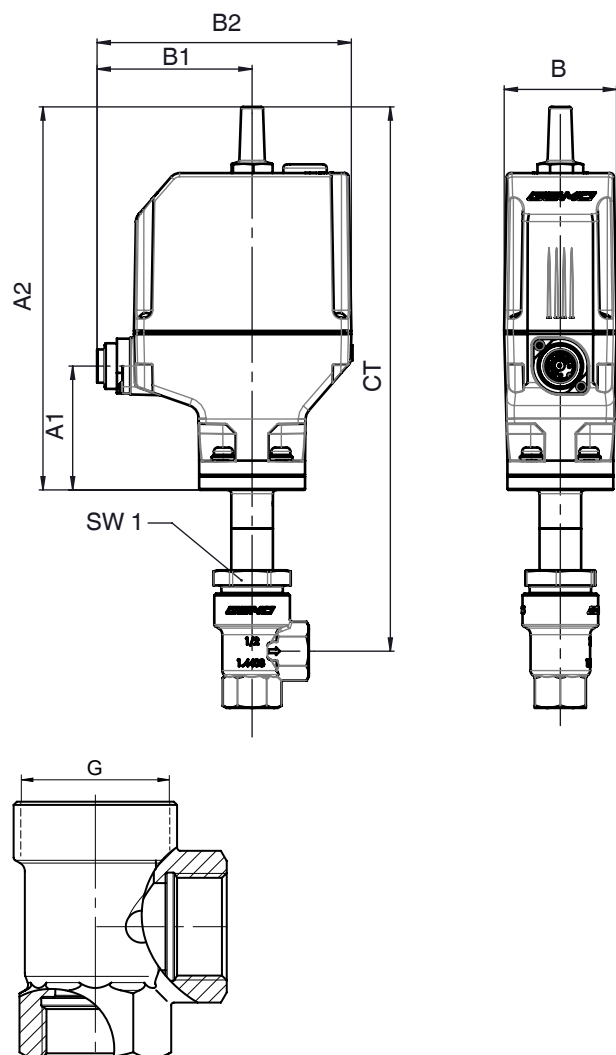

DN	Actuator version	A1	A2	B	B1	B2	CT	G	SW1
15	1A	65.5	203.0	59.5	82.0	134.5	288.0	M35x1.5	36
20	1A	65.5	203.0	59.5	82.0	134.5	291.0	M40x1.5	41
25	1A	65.5	203.0	59.5	82.0	134.5	295.0	M45x1.5	46
32	1A	65.5	203.0	59.5	82.0	134.5	298.0	M52x1.5	55
40	1A	65.5	203.0	59.5	82.0	134.5	311.0	M60x2	60
40	3A	72.0	232.0	80.0	94.5	167.0	341.0	M60x2	60
50	1A	65.5	203.0	59.5	82.0	134.5	316.0	M72x2	75
50	3A	72.0	232.0	80.0	94.5	167.0	346.0	M72x2	75

Dimensions in mm

Body dimensions

Spigot DIN/EN/ISO/ASME/SMS (code 0, 16, 17, 37, 59, 60, 65)

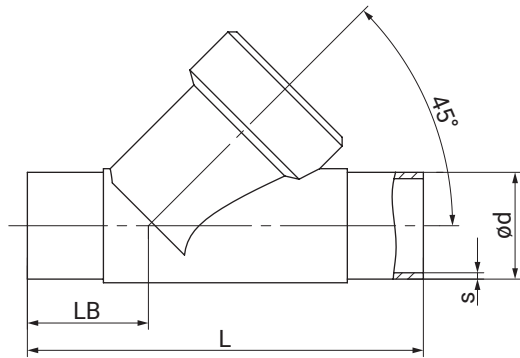

Connection type spigot DIN/EN/ISO (code 0, 16, 17, 60)¹⁾, investment casting material (code 34)²⁾

DN	NPS	$\varnothing d$				L	LB	s			
		Connection type						Connection type			
		0	16	17	60			0	16	17	60
15	1/2"	18.0	18.0	19.0	21.3	105.0	35.5	1.5	1.0	1.5	1.6
20	3/4"	22.0	22.0	23.0	26.9	120.0	39.0	1.5	1.0	1.5	1.6
25	1"	28.0	28.0	29.0	33.7	125.0	38.5	1.5	1.0	1.5	2.0
32	1 1/4"	-	34.0	35.0	42.4	155.0	48.0	-	1.0	1.5	2.0
40	1 1/2"	40.0	40.0	41.0	48.3	160.0	47.0	1.5	1.0	1.5	2.0
50	2"	52.0	52.0	53.0	60.3	180.0	48.0	1.5	1.0	1.5	2.0

Connection type spigot ANSI/ASME/SMS (code 37, 59, 65)¹⁾, investment casting material (code 34)²⁾

DN	NPS	$\varnothing d$			L	LB	s		
		Connection type					Connection type		
		37	59	65			37	59	65
15	1/2"	-	12.70	21.3	105.0	35.5	-	1.65	2.77
20	3/4"	-	19.05	26.7	120.0	39.0	-	1.65	2.87
25	1"	25.0	25.40	33.4	125.0	38.5	1.2	1.65	3.88
32	1 1/4"	-	-	42.4	155.0	48.0	-	-	3.56
40	1 1/2"	38.0	38.10	48.3	160.0	47.0	1.2	1.65	3.68
50	2"	51.0	50.80	60.3	180.0	48.0	1.2	1.65	3.91

Dimensions in mm

1) **Connection type**

- Code 0: Spigot DIN
- Code 16: Spigot EN 10357 series B, formerly DIN 11850 series 1
- Code 17: Spigot EN 10357 series A / DIN 11866 series A formerly DIN 11850 series 2
- Code 37: Spigot SMS 3008
- Code 59: Spigot ASME BPE/DIN 11866 series C
- Code 60: Spigot ISO 1127/EN 10357 series C/DIN 11866 series B
- Code 65: Spigot ANSI/ASME B36.19M schedule 40s

2) **Valve body material**

- Code 34: 1.4435, investment casting

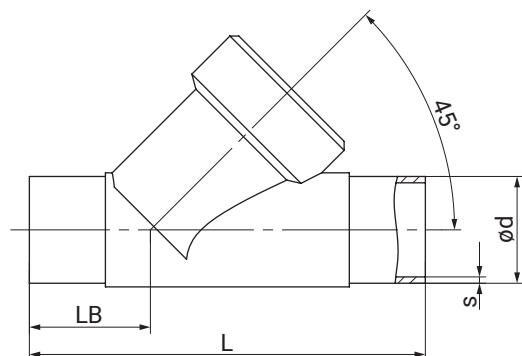
Spigot EN/ISO/ASME/SMS (code 17, 37, 59, 60, 63)**Connection type spigot EN/ISO/ASME (code 17, 60, 63)¹⁾, investment casting material (code 37)²⁾**

DN	NPS	ød			L	LB	s		
		Connection type					Connection type		
		17	60	63			17	60	63
15	1/2"	19.0	21.3	21.3	100.0	33.0	1.5	1.6	2.11
20	3/4"	23.0	26.9	26.7	108.0	33.0	1.5	1.6	2.11
25	1"	29.0	33.7	33.4	112.0	32.0	1.5	2.0	2.77
32	1 1/4"	35.0	42.4	-	137.0	39.0	1.5	2.0	-
40	1 1/2"	41.0	48.3	48.3	146.0	40.0	1.5	2.0	2.77
50	2"	53.0	60.3	60.3	160.0	38.0	1.5	2.0	2.77
65	2 1/2"	70.0	76.1	73.0	290.0	96.0	2.0	2.0	3.05
80	3"	85.0	88.9	88.9	310.0	95.0	2.0	2.3	3.05

Connection type spigot ASME/SMS (code 37, 59)¹⁾, investment casting material (code 37)²⁾

DN	NPS	ød		L	LB	s	
		Connection type				Connection type	
		37	59			37	59
65	2 1/2"	63.5	63.5	290.0	96.0	1.6	1.65
80	3"	76.1	76.0	310.0	95.0	1.6	1.65

Dimensions in mm

1) Connection type

Code 17: Spigot EN 10357 series A / DIN 11866 series A formerly DIN 11850 series 2

Code 37: Spigot SMS 3008

Code 59: Spigot ASME BPE/DIN 11866 series C

Code 60: Spigot ISO 1127/EN 10357 series C/DIN 11866 series B

Code 63: Spigot ANSI/ASME B36.19M schedule 10s

2) Valve body material

Code 37: 1.4408, investment casting

Spigot EN/ISO/ASME (code 17, 59, 60)

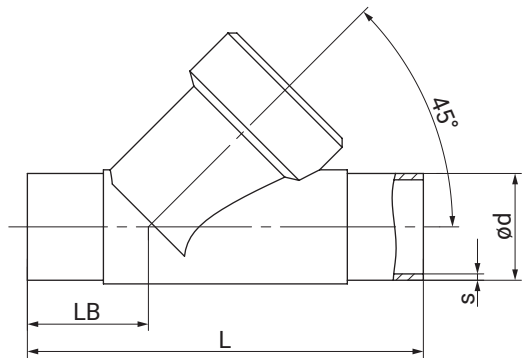

Connection type spigot EN/ISO/ASME (code 17, 59, 60)¹⁾, investment casting material (code C2)²⁾

DN	NPS	ød			L	LB	s		
		Connection type					Connection type		
		17	59	60			17	59	60
15	1/2"	19.0	12.70	21.3	105.0	35.5	1.5	1.65	1.6
20	3/4"	23.0	19.05	26.9	120.0	39.0	1.5	1.65	1.6
25	1"	29.0	25.40	33.7	125.0	39.5	1.5	1.65	2.0
32	1¼"	35.0	-	42.4	155.0	48.0	1.5	-	2.0
40	1½"	41.0	38.10	48.3	160.0	47.0	1.5	1.65	2.0
50	2"	53.0	50.80	60.3	180.0	48.0	1.5	1.65	2.0
65	2½"	70.0	63.50	76.1	290.0	96.0	2.0	1.65	2.0
80	3"	85.0	76.20	88.9	310.0	95.0	2.0	1.65	2.3

Dimensions in mm

1) **Connection type**

Code 17: Spigot EN 10357 series A / DIN 11866 series A formerly DIN 11850 series 2

Code 59: Spigot ASME BPE/DIN 11866 series C

Code 60: Spigot ISO 1127/EN 10357 series C/DIN 11866 series B

2) **Valve body material**

Code C2: 1.4435, investment casting

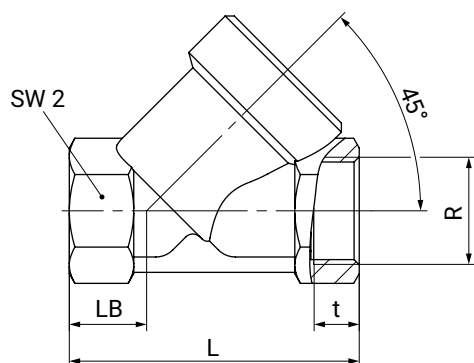
Threaded socket DIN/Rc/NPT body configuration D (code 1, 3C, 3D)**Connection type threaded socket DIN (code 1)¹⁾, investment casting material (code 37)²⁾**

DN	NPS	L	LB	R	SW2	t
15	1/2"	65.0	16.5	G 1/2	27	15.0
20	3/4"	75.0	17.5	G 3/4	32	16.3
25	1"	90.0	24.0	G 1	41	19.1
32	1 1/4"	110.0	33.0	G 1 1/4	50	21.4
40	1 1/2"	120.0	30.0	G 1 1/2	55	21.4
50	2"	150.0	40.0	G 2	70	25.7
65	2 1/2"	190.0	46.0	G 2 1/2	85	30.2
80	3"	220.0	50.0	G 3	100	33.3

Connection type threaded socket Rc/NPT (code 3C, 3D)¹⁾, investment casting material (code 37)²⁾

DN	NPS	L	LB	R		SW2	t	
				Connection type			Connection type	
				3C	3D		3C	3D
15	1/2"	65.0	16.5	Rc 1/2	1/2" NPT	27	15.0	13.6
20	3/4"	75.0	17.5	Rc 3/4	3/4" NPT	32	16.3	14.1
25	1"	90.0	24.0	Rc 1	1" NPT	41	19.1	17.0
32	1 1/4"	110.0	33.0	Rc 1 1/4	1 1/4" NPT	50	21.4	17.5
40	1 1/2"	120.0	30.0	Rc 1 1/2	1 1/2" NPT	55	21.4	17.3
50	2"	150.0	40.0	Rc 2	2" NPT	70	25.7	17.8
65	2 1/2"	190.0	46.0	Rc 2 1/2	2 1/2" NPT	85	30.2	23.7
80	3"	220.0	50.0	Rc 3	3" NPT	100	33.3	25.8

Dimensions in mm

1) Connection type

Code 1: Threaded socket DIN ISO 228

Code 3C: Threaded socket Rc ISO 7-1, EN 10226-2, JIS B 0203, BS 21, end-to-end dimension ETE DIN 3202-4 series M8

Code 3D: Threaded socket NPT, end-to-end dimension ETE DIN 3202-4 series M8

2) Valve body material

Code 37: 1.4408, investment casting

Threaded socket DIN/NPT body configuration E (code 1, 3D)

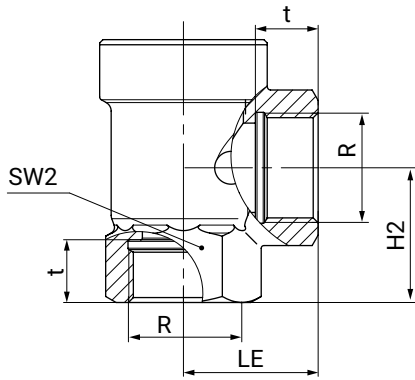

Connection type threaded socket DIN/NPT (code 1, 3D)¹⁾, investment casting material (code 37)²⁾

DN	NPS	H2	LE	SW2	R		t	
					Connection type		Connection type	
					1	3D	1	3D
15	1/2"	30.0	30.0	27	G 1/2	1/2" NPT	15.0	13.6
20	3/4"	37.5	35.0	32	G 3/4	3/4 " NPT	16.3	14.1
25	1"	41.0	41.0	41	G 1	1" NPT	19.1	17.0
32	1 1/4"	48.0	50.0	50	G 1 1/4	1 1/4" NPT	21.4	17.5
40	1 1/2"	55.0	50.0	55	G 1 1/2	1 1/2" NPT	21.4	17.3
50	2"	62.0	60.0	70	G 2	2" NPT	25.7	17.8

Dimensions in mm

- 1) **Connection type**
 Code 1: Threaded socket DIN ISO 228
 Code 3D: Threaded socket NPT, end-to-end dimension ETE DIN 3202-4 series M8
- 2) **Valve body material**
 Code 37: 1.4408, investment casting

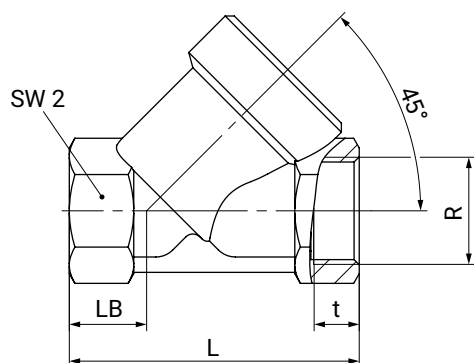
Threaded socket DIN/NPT (code 1, 3D)**Connection type threaded socket DIN/NPT (code 1, 3D)¹⁾, block material (code 9)²⁾**

DN	NPS	L	LB	R		SW2	t	
				Connection type			Connection type	
				1	3D		1	3D
15	1/2"	65.0	16.5	G 1/2	1/2" NPT	27	15.0	13.6
20	3/4"	75.0	17.5	G 3/4	3/4" NPT	32	16.3	14.1
25	1"	90.0	24.0	G 1	1" NPT	41	19.1	17.0
32	1 1/4"	110.0	33.0	G 1 1/4	1 1/4" NPT	50	21.4	17.5
40	1 1/2"	120.0	30.0	G 1 1/2	1 1/2" NPT	55	21.4	17.3
50	2"	150.0	40.0	G 2	2" NPT	70	25.7	17.8
65	2 1/2"	190.0	46.0	G 2 1/2	2 1/2" NPT	85	30.2	23.7
80	3"	220.0	50.0	G 3	3" NPT	100	33.3	25.8

Dimensions in mm

1) Connection type

Code 1: Threaded socket DIN ISO 228

Code 3D: Threaded socket NPT, end-to-end dimension ETE DIN 3202-4 series M8

2) Valve body material

Code 9: CC499K, cast bronze

Threaded spigot DIN (code 9)

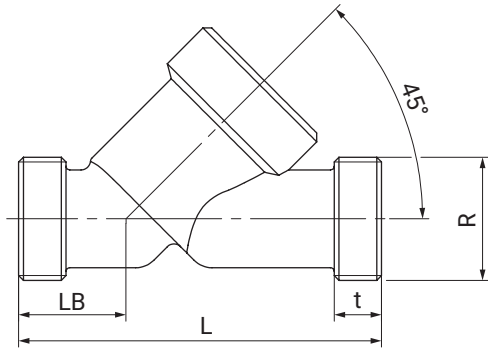

Connection type threaded spigot DIN (code 9)¹⁾, investment casting material (code 9)²⁾

DN	NPS	L	LB	R	t
15	1/2"	90.0	25.0	G 3/4	12.0
20	3/4"	110.0	30.0	G 1	15.0
25	1"	118.0	30.0	G 1 1/4	15.0
40	1 1/2"	140.0	35.0	G 1 3/4	13.0
50	2"	175.0	50.0	G 2 3/8	15.0
65	2 1/2"	216.0	52.0	G 3	15.0
80	3"	254.0	64.0	G 3 1/2	18.0

Connection type threaded spigot DIN (code 9)¹⁾, investment casting material (code 37)²⁾

DN	NPS	L	LB	R	t
15	1/2"	90.0	25.0	G 3/4	12.0
20	3/4"	110.0	30.0	G 1	15.0
25	1"	118.0	30.0	G 1 1/4	15.0
32	1 1/4"	130.0	38.0	G 1 1/2	13.0
40	1 1/2"	140.0	35.0	G 1 3/4	13.0
50	2"	175.0	50.0	G 2 3/8	15.0
65	2 1/2"	216.0	52.0	G 3	15.0
80	3"	254.0	64.0	G 3 1/2	18.0

Dimensions in mm

- 1) **Connection type**
Code 9: Threaded spigot DIN ISO 228
- 2) **Valve body material**
Code 9: CC499K, cast bronze
Code 37: 1.4408, investment casting

Flange, special length EN/ANSI (code 13, 47)

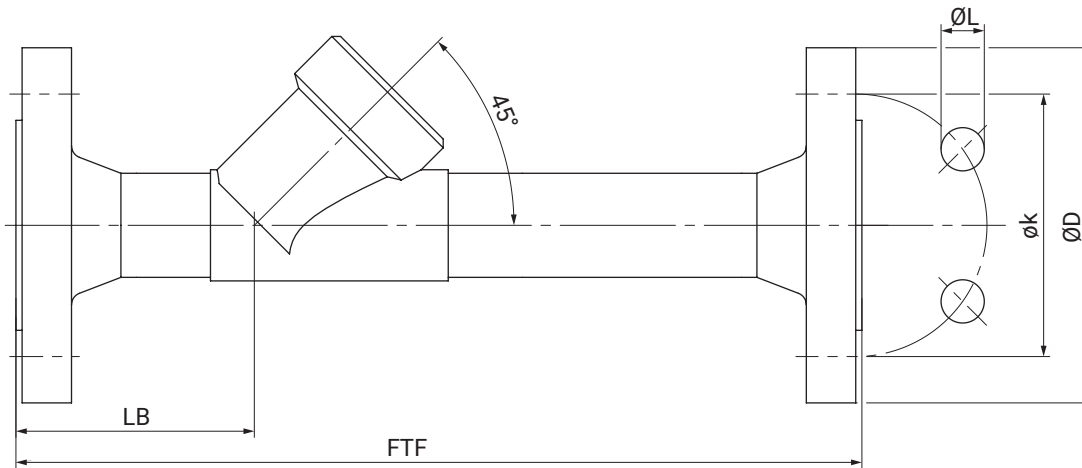

Connection type flange, special length EN/ANSI (code 13, 47)¹⁾, investment casting material (code 34)²⁾

DN	NPS	ØD		FTF	øk		ØL		LB	n
		Connection type			Connection type		Connection type			
		13	47		13	47	13	47		
15	1/2"	95.0	89.0	210.0	65.0	60.5	14.0	15.7	72.0	4
20	3/4"	105.0	98.6	280.0	75.0	69.8	14.0	15.7	78.0	4
25	1"	115.0	108.0	280.0	85.0	79.2	14.0	15.7	77.0	4
32	1 1/4"	140.0	117.3	310.0	100.0	88.9	18.0	15.7	89.0	4
40	1 1/2"	150.0	127.0	320.0	110.0	98.6	18.0	15.7	91.0	4
50	2"	165.0	152.4	330.0	125.0	120.7	18.0	19.1	95.0	4

Dimensions in mm
n = number of bolts

- 1) **Connection type**
Code 13: Flange EN 1092, PN 25, form B
Code 47: Flange ANSI Class 150 RF
- 2) **Valve body material**
Code 34: 1.4435, investment casting

Clamp DIN/ASME (code 80, 82, 86, 88)

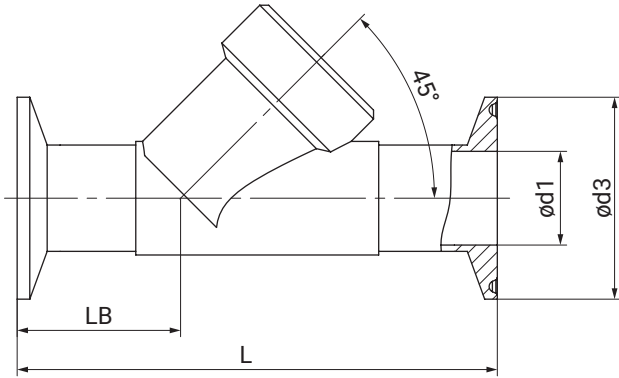

Connection type clamp DIN/ASME (code 80, 82, 86, 88)¹⁾, investment casting material (code 34)²⁾

DN	NPS	ød1				ød3				L				LB			
		Connection type				Connection type				Connection type				Connection type			
		80	82	86	88	80	82	86	88	80	82	86	88	80	82	86	88
15	1/2"	9.40	18.1	16.0	9.40	25.0	50.5	34.0	25.0	101.6	130.0	130.0	130.0	33.5	47.5	47.5	47.5
20	3/4"	15.75	23.7	20.0	15.75	25.0	50.5	34.0	25.0	101.6	150.0	150.0	150.0	30.0	54.0	54.0	54.0
25	1"	22.10	29.7	26.0	22.10	50.5	50.5	50.5	50.5	114.3	160.0	160.0	160.0	33.0	56.0	56.0	56.0
32	1 1/4"	-	38.4	32.0	-	-	64.0	50.5	-	-	180.0	180.0	-	-	62.0	62.0	-
40	1 1/2"	34.80	44.3	38.0	34.80	50.5	64.0	50.5	50.5	139.7	200.0	200.0	200.0	37.0	67.0	67.0	67.0
50	2"	47.50	56.3	50.0	47.50	64.0	77.5	64.0	64.0	158.8	230.0	230.0	230.0	36.5	73.0	73.0	73.0

Dimensions in mm

1) **Connection type**

- Code 80: Clamp ASME BPE, face-to-face dimension FTF ASME BPE
- Code 82: Clamp DIN 32676 series B, face-to-face dimension FTF EN 558 series 1
- Code 86: Clamp DIN 32676 series A, face-to-face dimension FTF EN 558 series 1
- Code 88: Clamp ASME BPE, for pipe ASME BPE, face-to-face dimension FTF EN 558 series 1

2) **Valve body material**

- Code 34: 1.4435, investment casting

Accessories



GEMÜ 1215

Electrical position indicator

The GEMÜ 1215 electrical position indicator is suitable for mounting to pneumatically operated linear actuators. The position (end position open) of the valve spindle is reliably detected and fed back electronically by the operating bush with a microswitch.

The product cannot be ordered later. It must be selected as order option "Control module" (see order data) when ordering.



GEMÜ 1218

Connector

The GEMÜ 1218 is a connector (cable socket / cable plug), 7-pin. Straight and/or 90° angled plug type.

GEMÜ 1218 Binder connector			
Connection X1 – supply voltage, relay outputs			
Binder plug	468/eSy series mating connector	Terminal compartment/ screws, 7-pin	88220649 ¹⁾
		Terminal compartment/ screws, 7-pin, 90°	88377714
		Terminal compartment/ screws, 7-pin, 90°, fitted with a 2 metre cable set	88770522

1) provided in the scope of delivery



GEMÜ 1573

Switching power supply unit

The GEMÜ 1573 switching power supply unit converts unstable input voltages from 100 to 240 V AC into a continuous DC voltage. It can be used as an accessory for valves with motorized actuators e. g. GEMÜ eSyLite, eSyStep und eSyDrive and for additional devices with a 24 V DC power supply. Different power levels, output currents and a 48 V DC version for servoDrive actuators are available.

GEMÜ 1573 switching power supply unit			
Input voltage	Output voltage	Output current	Item number
100 - 240 V AC	24 V DC	5 A	88660400
		10 A	88660401



GEMÜ Gebr. Müller Apparatebau GmbH & Co. KG
Fritz-Müller-Straße 6-8, 74653 Ingelfingen-Criesbach, Germany
Phone +49 (0) 7940 1230 · info@gemue.de
www.gemu-group.com