

Globe Control Valve, Metal

Construction

The GEMÜ 534 2/2-way globe control valve is designed for demanding flow control applications. It can be paired with the GEMÜ 1434 μ Pos, GEMÜ 1435 ePos positioners or the GEMÜ 1436 cPos positioner and process controller dependent on the control requirements (for features see page 8). The positioners are specially designed for GEMÜ valves and achieve optimum results when used as a system. The valve spindle is sealed by a self-adjusting gland packing providing low maintenance and reliable sealing even after a long service life with high cycle duties. A wiper ring protects the gland packing against contamination and damage.

Features

- Linear or modified equal-percentage control characteristics
- Cv values from approx. 0.2 - 163.8 gpm, depending on nominal size, valve seat and regulating cone design
- PID control system can be implemented with GEMÜ 1436
- Suitable for inert, corrosive*, liquid and gaseous media and steam
- Flanged bodies in SG iron GGG 40.3 and stainless steel 1.4408 to EN 1092 and ANSI 125/150
- Valve body DN 15 - 100, pressure rating to PN 40
- Max. operating temperature 356 °F

Advantages

- Simple and fast commissioning
- Valve and positioner are optimally adapted to each other.
(For positioner details please refer to the relevant data sheets)
- Standard gland packing suitable for vacuum up to 0.59 inHg (abs.)

*see information on working medium on page 2



GEMÜ 534
+ 1434 μ Pos

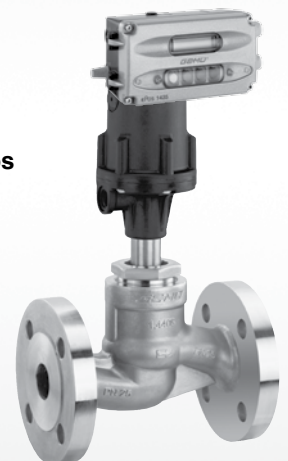

GEMÜ 534
+ 1435 ePos



GEMÜ 534
+ 1436 cPos

Sectional drawing

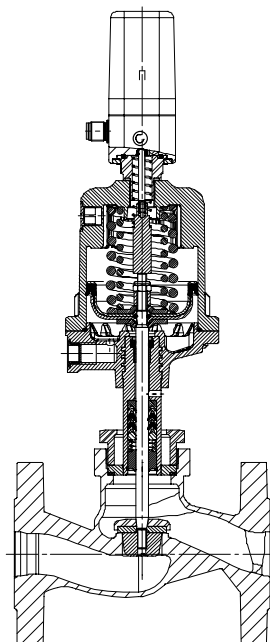

Technical data

Working medium

Corrosive, inert, gaseous and liquid media and steam which have no negative impact on the physical and chemical properties of the body and seal material.

Max. perm. pressure of working medium see table

Media temperature 14 °F to 356 °F

Max. permissible viscosity 600 mm²/s (cSt)

Control medium

Inert gases, max. 140 °F

Filling volume	Actuator size 0:	3.05 cu in
	Actuator size 1:	7.63 cu in
	Actuator size 2:	38.14 cu in

Ambient conditions

Max. ambient temperature 140 °F

Maximum permissible seat leakage class

Seat seal	Standard	Test procedure	Leakage rate	Test medium
PTFE	DIN EN 60534-4	1	VI	air
Metal	DIN EN 60534-4	1	IV	air

Pressure / temperature correlation for globe valve bodies

Connection code	Material code	Max. allowable operating pressures in psi at temperature °F*					
		RT	212	302	392	482	572
8	37	232	232	210	194	184	171
10	37	363	363	329	305	287	268
11	37	580	580	526	489	461	431
39	37	276	232	215	197	174	148
8	90	232	232	225	213	202	162
39	90	247	232	215	202	175	148

* The valves can be used down to 14 °F RT = Room Temperature All pressures are gauge pressures.
Pressure/temperature correlation for connection code 48: DN 15 - 40 see connection code 10, DN 50 see connection code 8.

Example Cv value diagram

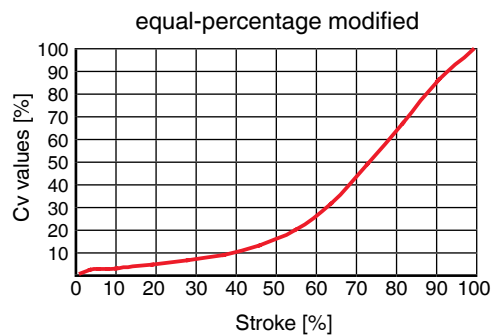
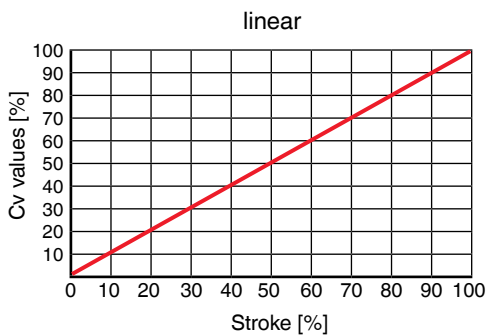

The adjacent diagram shows the approximative curve of the Cv value characteristic. The characteristic may deviate dependent on valve body, nominal size, regulating cone and valve stroke.

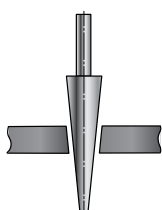

Regulating needle

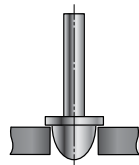

Regulating cone

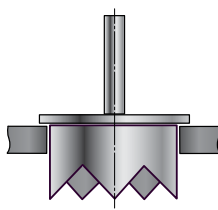

Regulating cage

Note:

Regulating needle: RAxxx - RCxxx (reduced valve seat)

Regulating cone: DN 15 - DN 50

Regulating cage: DN 65 - DN 100

Correlation Cv value, operating pressure, regulating cone number
Valve body material: 1.4408 (code 37) and GGG 40.3 (code 90)

Nominal size	Cv value [gpm]	Operating pressure [psi] *	Actuator size	Regulating cone number	
DN				linear	equal-percentage (mod.)
15	4.7	174	0	RS021	RS031
		580	1	RS020	RS030
20	7.4	90	0	RS022	RS032
		290	1	RS023	RS033
25	11.7	150	1	RS024	RS034
32	18.7	105	1	RS028	RS038
		290	2	RS025	RS035
40	29.3	65	1	RS029	RS039
		174	2	RS026	RS036
50	46.8	45	1	RS363	RS353
		150	2	RS027	RS037
65	73.7	105	2	-	RS350
80	105.3	75	2	-	RS351
100	163.8	36	2	-	RS352

* Observe the pressure / temperature correlation

Correlation Cv value, operating pressure, regulating cone number
Valve body material: 1.4408 (code 37)

Nominal size	Cv-Wert [gpm]	Operating pressure [psi] **	Actuator size	Regulating cone number	
DN				linear	equal-percentage (mod.)
15	0.1*	580	1	RA101	RA301
	0.2*	580	1	RB101	RA302
	0.3*	580	1	RB102	RB302
	0.5*	580	1	RB103	RB301
	0.7*	580	1	RC101	RC301
	1.2*	580	1	RC102	RC302
	1.9	580	1	RD101	RD301
	2.9	580	1	RE101	RE301
20	1.9	580	1	RD102	RD302
	2.9	580	1	RE102	RE302
	4.7	580	1	RF101	RF301
25	2.9	580	1	RE103	RE303
	4.7	580	1	RF102	RF303
	7.4	580	1	RG101	RG301
32	4.7	580	1	RF103	RF302
	7.4	580	1	RG102	RG302
	11.7	232	1	RH102	RH301
40	7.4	580	1	RG103	RG303
	11.7	261	1	RH101	RH302
	18.7	160	1	RJ101	RJ302
50***	11.7	232	1	RH103	RH303
	18.7	174	1	RJ102	RJ301
	29.3	232	2	RK101	RK301

* metal seated (with no soft seat)

** Observe the pressure / temperature correlation

*** only for connection code 8, 39, 48

Order data

Body configuration	Code
2/2-way body	D

Nominal size	Code
DN 15 NPS 1/2"	15
DN 20 NPS 3/4"	20
DN 25 NPS 1"	25
DN 32 NPS 1 1/4"	32
DN 40 NPS 1 1/2"	40
DN 50 NPS 2"	50
DN 65 NPS 2 1/2"	65
DN 80 NPS 3"	80
DN 100 NPS 4"	100

Connection	Code
Flanges EN 1092 / PN16 / form B, length EN 558, series 1, ISO 5752, basic series 1	8
Flanges EN 1092 / PN25 / form B, length EN 558, series 1, ISO 5752, basic series 1	10
Flanges EN 1092 / PN40 / form B, length EN 558, series 1, ISO 5752, basic series 1	11
Flanges ANSI CLASS 125/150 RF, length EN 558, series 1, ISO 5752, basic series 1	39
Flanges drilled according to JIS 20K (DN 15 - 40), Flanges drilled according to JIS 10K (DN 50), length EN 558, series 10, ASME/ANSI B 16.10 table 1, column 16	48

Valve body material	Code
1.4408, Investment casting	37
EN-GJS-400-18-LT (GGG 40.3) SG iron	90

Seat seal	Code
PTFE	5
PTFE, glass fibre reinforced	5G
Steel (standard up to Cv value 1.2 gpm)	10*
* R-No. on request	

Control function	Code
Normally closed (NC)	1
Double acting (DA)	3*
Double acting (normally open)	8*
* R-No. on request	

Actuator size	Flow	Code
Actuator 0 piston ø 1.97 in	under the seat	0
Actuator 1 piston ø 2.76 in	under the seat	1
Actuator 2 piston ø 4.72 in	under the seat	2

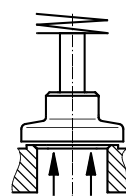

Flow under the seat

Regulating cone	R-No.
For the regulating cone no. (R-No.) - linear or equal-percentage (mod.) please refer to the table	

Version	Code
Gland packing PTFE / PTFE suitable for contact with food according to EU Regulation 1935/2004	2013

Order data

Order example	534	25	D	10	37	5	1	1	RS034	-
Type	534									
Nominal size		25								
Body configuration (code)			D							
Connection (code)				10						
Valve body material (code)					37					
Seat seal (code)						5				
Control function (code)							1			
Actuator size (code)								1		
Regulating cone (R-No.)									RS034	
Version (Code)										-

For the technical data and order data of the positioners please refer to data sheets GEMÜ 1434, 1435 and 1436. Please also note the table on the last page.

Version for food contact

For food contact, the product must be ordered with the following ordering options:

Version code 2013

Seat seal code 5, 5G, 10

Valve body material code 37

Actuator dimensions / Installation dimensions [inch]

Actuator dimensions

Actuator size	øB	M	A2	G
0 + 3	2.83	M16x1	2.76	G 1/4
1 + 4	3.78	M16x1	3.39	G 1/4
2	6.61	M22x1.5	5.87	G 1/4

Installation dimensions / weight of valve

		Actuator size 0 + 3		Actuator size 1 + 4		Actuator size 2	
DN	SW1 metric [mm]	CT [in]	Weight [lbs]	CT [in]	Weight [lbs]	CT [in]	Weight [lbs]
15	36	7.48	6.8	8.58	7.9	-	17.2
20	41	7.76	9.0	8.86	10.1	12.6	19.0
25	46	8.19	11.0	9.29	12.1	13.03	20.5
32	55	-	-	9.49	17.0	13.23	24.0
40	60	-	-	9.92	19.8	13.66	26.2
50	75	-	-	10.24	26.0	13.98	30.9
65	75	-	-	-	-	15.08	-
80	75	-	-	-	-	15.67	-
100	75	-	-	-	-	16.50	-

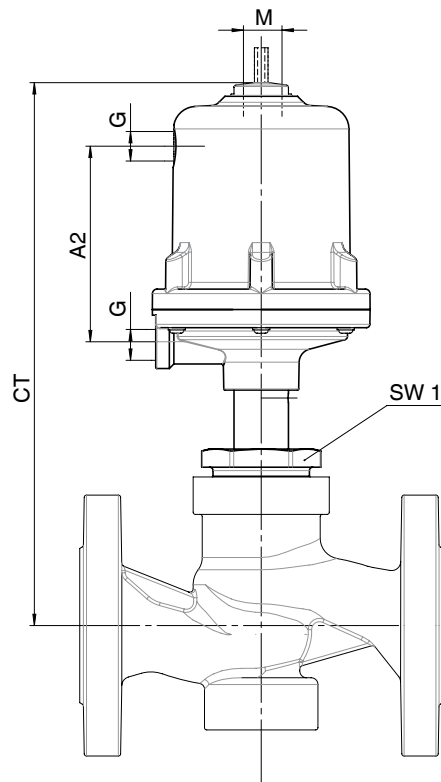

Dimensions - GEMÜ 534 [inch]

GEMÜ 534 with 1434 μ Pos

DN	Actuator size	Control function	$\varnothing B$	HAR
15	0	1	2.83	11.57
	1	1	3.78	12.68
20	0	1	2.83	11.85
	1	1	3.78	12.95
25	0	1	2.83	12.28
	1	1	3.78	13.39
32	1	1	3.78	13.58
40	1	1	3.78	14.02
50	1	1	3.78	14.33

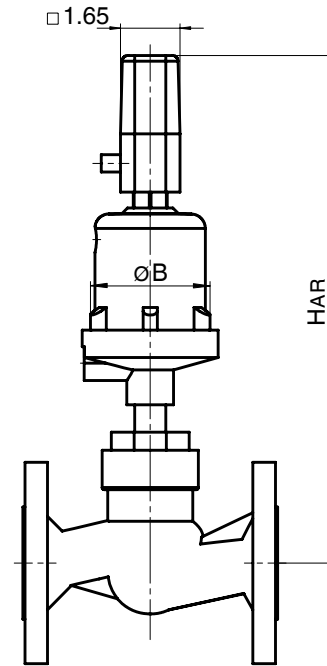

GEMÜ 534 with 1435 ePos

DN	Actuator size	Control function	øB	HAW	HAR	LAR
15	0	1	2.83	9.88	10.94	4.65
	1	1	3.78	10.98	12.05	4.65
		3 and 8	3.78	11.93	12.99	4.65
20	0	1	2.83	10.16	11.22	4.65
	1	1	3.78	11.26	12.32	4.65
		3 and 8	3.78	12.20	13.27	4.65
		1	6.61	16.06	16.26	5.43
	2	3 and 8	6.61	16.81	17.01	5.43
25	0	1	2.83	10.59	11.65	4.65
	1	1	3.78	11.69	12.76	4.65
		3 and 8	3.78	12.64	13.70	4.65
		1	6.61	16.50	16.69	5.43
	2	3 and 8	6.61	17.24	17.44	5.43
32	1	1	3.78	11.89	12.95	4.65
		3 and 8	3.78	12.83	13.90	4.65
		1	6.61	16.69	16.89	5.43
	2	3 and 8	6.61	17.44	17.64	5.43
40	1	1	3.78	12.32	13.39	4.65
		3 and 8	3.78	13.27	14.33	4.65
		1	6.61	17.13	17.32	5.43
	2	3 and 8	6.61	17.87	18.07	5.43
50	1	1	3.78	12.64	13.70	4.65
		3 and 8	3.78	13.58	14.65	4.65
	2	1	6.61	17.44	17.64	5.43
		3 u. 8	6.61	18.19	18.39	5.43
65	2	1	6.61	14.53	14.72	5.43
		3 and 8	6.61	15.28	15.47	5.43
80	2	1	6.61	14.53	14.72	5.43
		3 and 8	6.61	15.28	15.47	5.43
100	2	1	6.61	14.53	14.72	5.43
		3 and 8	6.61	15.28	15.47	5.43

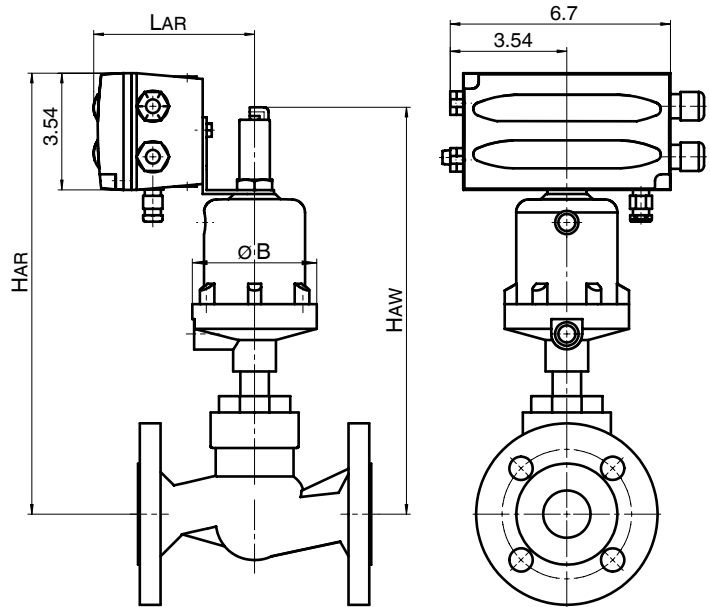

Dimensions - GEMÜ 534 [inch]

GEMÜ 534 with 1436 cPos

DN	Actuator size	Control function	øB	HAR
15	0	1, 3	2.83	13.66
	1	1	3.78	13.82
		3	3.78	14.76
20	0	1, 3	2.83	13.94
	1	1	3.78	14.09
		3	3.78	15.04
	2	1	6.61	18.90
3		6.61	19.65	
25	0	1, 3	2.83	14.37
	1	1	3.78	14.53
		3	3.78	15.47
	2	1	6.61	19.37
		3	6.61	20.08
32	1	1	3.78	14.72
		3	3.78	15.67
	2	1	6.61	19.53
		3	6.61	20.28
40	1	1	3.78	15.16
		3	3.78	16.10
	2	1	6.61	20.00
		3	6.61	20.71
50	1	1	3.78	15.47
		3	3.78	16.42
	2	1	6.61	20.31
		3	6.61	21.02
65	2	1	6.61	17.40
		3	6.61	18.11
80	2	1	6.61	17.40
		3	6.61	18.11
100	2	1	6.61	17.40
		3	6.61	18.11

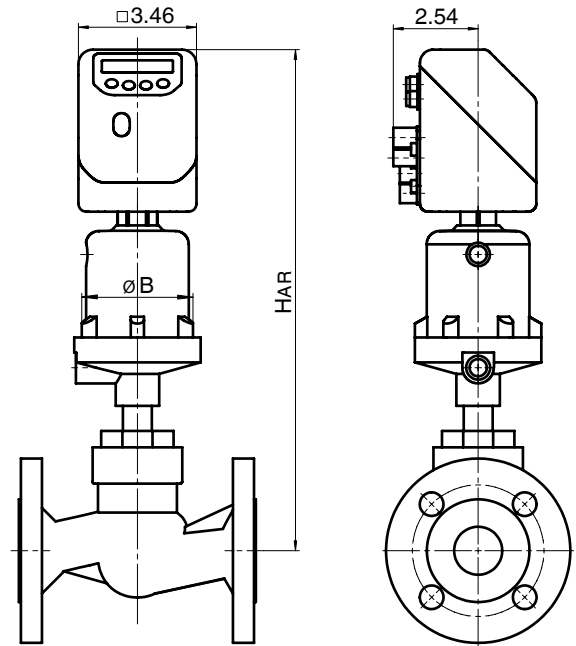

Body dimensions [inch]

Flanges, connection code 8, 10, 11, 39, 48
Valve body material 1.4408 (code 37), EN-GJS-400-18-LT (code 90)

DN	Number of bolts	Connection code 8, 10, 11				Connection code 39				Connection code 48				Weight [lbs]
		FTF	$\varnothing D$	$\varnothing K$	$\varnothing L$	FTF	$\varnothing D$	$\varnothing K$	$\varnothing L$	FTF	$\varnothing D$	$\varnothing K$	$\varnothing L$	
15	4	5.12	3.74	2.56	0.55	5.12	3.54	2.37	0.63	4.25	3.74	2.76	0.59	4.8
20	4	5.91	4.13	2.95	0.55	5.91	3.94	2.75	0.63	4.61	3.94	2.95	0.59	6.6
25	4	6.30	4.53	3.35	0.55	6.30	4.33	3.13	0.63	5.00	4.92	3.54	0.75	8.2
32	4	7.09	5.51	3.94	0.71	7.09	4.53	3.50	0.63	-	-	-	-	11.7
40	4	7.87	5.91	4.33	0.71	7.87	4.92	3.87	0.63	6.50	5.51	4.13	0.75	13.9
50	4	9.06	6.50	4.92	0.71	9.06	5.91	4.75	0.75	7.99	6.10	4.72	0.75	18.5

For materials see overview on page 10

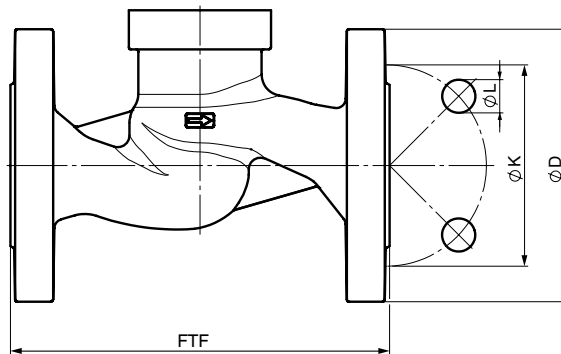

Flanges, connection code 8, 39
Valve body material 1.4408 (code 37), EN-GJS-400-18-LT (code 90)

DN	FTF	Connection code 8				Connection code 39				Weight [lbs]
		$\varnothing D$	$\varnothing K$	$\varnothing L$	Number of bolts	$\varnothing D$	$\varnothing K$	$\varnothing L$	Number of bolts	
65	11.42	7.28	5.71	0.71	4	7.09	5.50	0.75	4	28.0
80	12.2	7.87	6.30	0.71	8	7.48	6.00	0.75	4	33.9
100	13.78	8.66	7.09	0.71	8	9.06	7.50	0.75	8	50.7

For materials see overview on page 10

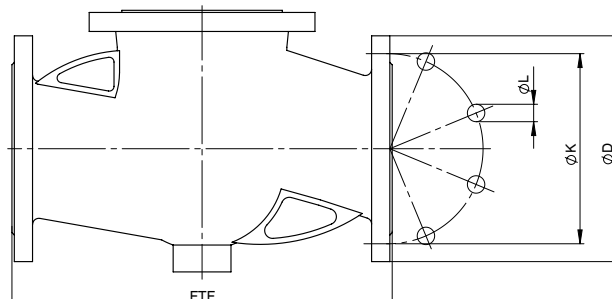

Overview of metal bodies for GEMÜ 534

Connection code	8		10	11	39		48
	37	90	37	37	37	90	37
DN 15	-	X	-	X	X	X	X
DN 20	-	X	-	X	X	X	X
DN 25	-	X	-	X	X	X	X
DN 32	-	X	X	X	X	X	-
DN 40	-	X	X	X	X	X	X
DN 50	X	X	-	X	X	X	X
DN 65	X	X	-	-	X	X	-
DN 80	X	X	-	-	X	X	-
DN 100	X	X	-	-	X	X	-

Specification sheet

for designing regulating cones for globe valves

Project (customer) _____ Valve/TAG number _____

Date _____ Telephone _____

Contact person _____ E-Mail _____

Technical requirements

Medium ¹⁾ _____

Requirement characteristic	1st operating point maximum flow	2nd operating point medium flow	3rd operating point minimum flow
Media temperature ⁴⁾	_____ °C	_____ °C	_____ °C
Inlet pressure	_____ bar(g)	_____ bar(g)	_____ bar(g)
Outlet pressure	_____ bar(g)	_____ bar(g)	_____ bar(g)
Flow rate ^{2, 3)}			
in [m ³ /h] for liquids	_____ m ³ /h	_____ m ³ /h	_____ m ³ /h
Gases ⁶⁾	_____ Nm ³ /h	_____ Nm ³ /h	_____ Nm ³ /h
in [kg/h] for steam	_____ kg/h	_____ kg/h	_____ kg/h

Valve body / Actuator	Type	_____		
	Required valve DN	_____		
	Max. operating pressure	_____		
	Ambient temperature ⁵⁾	_____		
	Max. media temperature	_____		
	Connection	_____		
	Body material	_____		
	Seat seal	<input type="radio"/> PTFE	<input type="radio"/> Other	
	Control function	<input type="radio"/> NC (normally closed)	<input type="radio"/> DA (double acting)	<input type="radio"/> Double acting (normally open)
	Control pressure	min	max	
Regulating cone	Characteristic	<input type="radio"/> linear	<input type="radio"/> modified equal-percentage	
	<input type="checkbox"/> Other	_____		

1) Liquid or gas?

For media other than water or air, it is necessary to give data for the density and viscosity (with unit of measurement) of the medium. Otherwise we will assume data for standard conditions.

2) For steam especially, the minimum or maximum flow rate should be assigned to the appropriate inlet or outlet pressure. The temperature of the medium should also be taken into account.

3) GEMÜ recommends a positioning ratio of 1 : 10 (e.g. minimum flow rate is 10 m³/h and the maximum flow rate is 100 m³/h). Please note that the valve only controls reliably from a flow of

about 10% of the max. Kv value on account of the valve opening behaviour. Other positioning ratios are possible on request or in the selection of standard regulating cones.

4) The media temperature range must be specified for steam applications. T = 20 °C is assumed unless specified otherwise.

5) This data is not absolutely necessary. A room temperature of 20 °C is assumed unless specified otherwise.

6) Basis: standard conditions 0 °C, 1013.25 mbar. If conditions differ, please specify them.

Positioner functions / features			
	1434 μ Pos	1435 ePos	1436 cPos
Controller type			
Positioner	X	X	X
Process controller			X
Control air flow			
Version 1	4 gpm	13.2 gpm	39.6 gpm
Version 2		23.8 gpm	52.8 gpm
Operation			
Local display / keypad		X	X
Status display	X	X	X
Web browser user			X
Field bus (Profibus DP, Device Net)			X
Signal			
24V DC / 3-wire	X	X	X
Body			
Plastic	X		X
Aluminium / industrial		X	
Functions			
Automatic initialisation	X	X	X
Alarm / error outputs		X	X
Min/max positions adjustable		X	X

GEMÜ 1434 μ Pos not available for actuator size 2

Other GEMÜ control valves



GEMÜ 514
+ 1434 μ Pos



GEMÜ 530
+ 1435 ePos



GEMÜ 532
+ 1435 ePos



GEMÜ 550
+ 1434 μ Pos



GEMÜ 554
+ 1435 ePos

For further globe valves, accessories and other products, please see our Product Range catalogue and Price List.
Contact GEMÜ.

GEMÜ VALVES, MEASUREMENT
AND CONTROL SYSTEMS

