

GEMÜ 655

Manually operated full bore diaphragm valve



Features

- High mechanical stability
- High flow rate due to straight through flow
- Can be retrofitted with a pneumatic actuator

Description

The GEMÜ 655 2/2-way diaphragm valve has a metal handwheel and is manually operated. The valve body has a full bore design.

Technical specifications

- **Media temperature:** 32 to 212 °F
- **Ambient temperature:** 32 to 140 °F
- **Operating pressure :** 0 to 150 psi
- **Nominal sizes:** 3/4" (DN 25) to 12" (DN 300)
- **Body configurations:** 2/2-way body
- **Connection standards:** ANSI | EN | ISO
- **Body materials:** EN-GJL-250, cast iron material | EN-GJS-400-18-LT, SG iron material | EN-GJS-500-7, ductile iron material
- **Body lining:** Butyl | Hard rubber | Soft rubber
- **Diaphragm materials:** CR | EPDM | IIR | NBR | NR
- **Conformities:** CRN | EAC

Technical data depends on the respective configuration



Product description

Construction

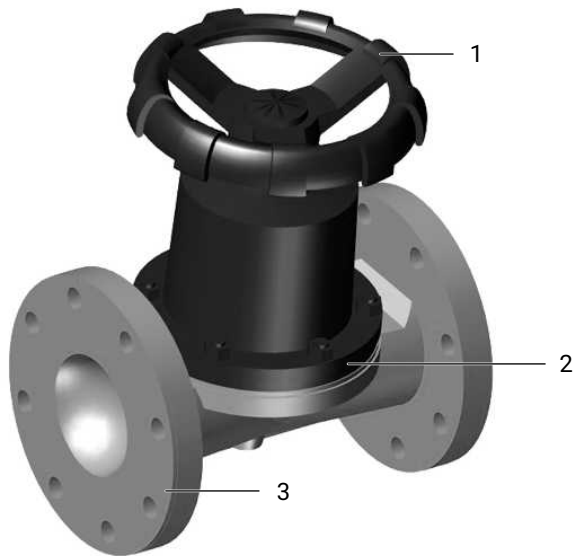

Item	Name	Materials
1	Actuator	Cast iron
2	Diaphragm	CR EPDM IIR NBR NR
3	Valve body	EN-GJL-250 (GG 25) EN-GJL-250 (GG 25), soft rubber lined EN-GJL-250 (GG 25), hard rubber lined EN-GJL-250 (GG 25), butyl lined EN-GJS-400-18-LT (GGG 40.3), soft rubber lined EN-GJS-400-18-LT (GGG 40.3), hard rubber lined EN-GJS-400-18-LT (GGG 40.3), butyl lined EN-GJS-500-7 (GGG 50), soft rubber lined EN-GJS-500-7 (GGG 50), hard rubber lined EN-GJS-500-7 (GGG 50), butyl lined

Availability

Flange EN 1092

MG	DN	Connection type code ¹⁾																
		4			8			52						53				
		Material code ²⁾																
		82	83	88	82	83	88	8	13	16	52	58	92	98	8	16	92	98
40	25	-	-	-	X	X	X	-	-	-	-	-	-	-	X	X	X	X
	40	-	-	-	X	X	X	-	-	-	-	-	-	-	X	X	X	X
65	50	-	-	-	X	X	X	-	-	-	-	-	-	-	X	X	X	X
	65	-	-	-	X	X	X	-	-	-	-	-	-	-	X	X	X	X
100	80	-	-	-	X	X	X	-	-	-	-	-	-	-	X	X	X	X
	100	-	-	-	X	X	X	-	-	-	-	-	-	-	X	X	X	X
150	125	-	-	-	X	X	X	-	-	-	-	-	-	-	X	X	X	X
	150	-	-	-	X	X	X	-	-	-	-	-	-	-	X	X	X	X
200	200	X	X	X	-	-	-	X	-	X	-	-	X	X	-	-	-	-
250	250	-	-	-	-	-	-	X*	X*	-	X*	X*	-	-	-	-	-	-
350	300	-	-	-	-	-	-	X*	X*	-	X*	X*	-	-	-	-	-	-

MG = diaphragm size, X = standard

* on request

1) Connection type

Code 4: Flange EN 1092, PN 10, form B, face-to-face dimension FTF EN 558 series 1, ISO 5752, basic series 1

Code 8: Flange EN 1092, PN 16, form B, face-to-face dimension FTF EN 558 series 1, ISO 5752, basic series 1

Code 52: Flange EN 1092, PN 10, form A, face-to-face dimension FTF EN 558 series 7, ISO 5752, basic series 7

Code 53: Flange EN 1092, PN 16, form A, face-to-face dimension FTF EN 558 series 7, ISO 5752, basic series 7

2) Valve body material

Code 8: EN-GJL-250 (GG 25)

Code 13: EN-GJL-250 (GG 25), hard rubber lined

Code 16: EN-GJS-500-7 (GGG-50), hard rubber lined

Code 52: EN-GJL-250 (GG 25), soft rubber lined

Code 58: EN-GJL-250 (GG 25), butyl lined

Code 82: EN-GJS-400-18-LT (GGG 40.3), soft rubber lined

Code 83: EN-GJS-400-18-LT (GGG 40.3), hard rubber lined

Code 88: EN-GJS-400-18-LT (GGG 40.3), butyl lined

Code 92: EN-GJS-500-7 (GGG 50), soft rubber lined

Code 98: EN-GJS-500-7 (GGG 50), butyl lined

Flange ANSI Class 125/150

MG	DN	Connection type code ¹⁾									
		39					58				
		Material code ²⁾									
		82	83	88	8	13	16	52	58	92	98
40	25	X	X	X	X	-	X	-	-	X	X
	40	X	X	X	X	-	X	-	-	X	X
65	50	X	X	X	X	-	X	-	-	X	X
	65	X	X	X	X	-	X	-	-	X	X
100	80	X	X	X	X	-	X	-	-	X	X
	100	X	X	X	X	-	X	-	-	X	X
150	125	X	X	X	X	-	X	-	-	X	X
	150	X	X	X	X	-	X	-	-	X	X
200	200	X	X	X	X	-	X	-	-	X	X
250	250	-	-	-	X *	X *	-	X *	X *	-	-
350	300	-	-	-	X *	X *	-	X *	X *	-	-

MG = diaphragm size, X = standard

* on request

1) Connection type

Code 39: Flange ANSI Class 125/150 RF, face-to-face dimension FTF EN 558 series 1, ISO 5752, basic series 1

Code 58: Flange ANSI Class 125/150 FF, face-to-face dimension FTF EN 558 series 7, ISO 5752, basic series 7

2) Valve body material

Code 8: EN-GJL-250 (GG 25)

Code 13: EN-GJL-250 (GG 25), hard rubber lined

Code 16: EN-GJS-500-7 (GGG-50), hard rubber lined

Code 52: EN-GJL-250 (GG 25), soft rubber lined

Code 58: EN-GJL-250 (GG 25), butyl lined

Code 82: EN-GJS-400-18-LT (GGG 40.3), soft rubber lined

Code 83: EN-GJS-400-18-LT (GGG 40.3), hard rubber lined

Code 88: EN-GJS-400-18-LT (GGG 40.3), butyl lined

Code 92: EN-GJS-500-7 (GGG 50), soft rubber lined

Code 98: EN-GJS-500-7 (GGG 50), butyl lined

Order data

The order data provide an overview of standard configurations.

Please check the availability before ordering. Other configurations available on request.

Order codes

1 Type	Code
Full bore diaphragm valve, manually operated, metal handwheel, metal bonnet	655

2 DN	Code
DN 25	25
DN 40	40
DN 50	50
DN 65	65
DN 80	80
DN 100	100
DN 125	125
DN 150	150
DN 200	200
DN 250	250
DN 300	300

3 Body configuration	Code
2/2-way body	D

4 Connection type	Code
Flange EN 1092, PN 10, form B, face-to-face dimension FTF EN 558 series 1, ISO 5752, basic series 1	4
Flange EN 1092, PN 16, form B, face-to-face dimension FTF EN 558 series 1, ISO 5752, basic series 1	8
Flange ANSI Class 125/150 RF, face-to-face dimension FTF EN 558 series 1, ISO 5752, basic series 1	39
Flange EN 1092, PN 10, form A, face-to-face dimension FTF EN 558 series 7, ISO 5752, basic series 7	52
Flange EN 1092, PN 16, form A, face-to-face dimension FTF EN 558 series 7, ISO 5752, basic series 7	53
Flange ANSI Class 125/150 FF, face-to-face dimension FTF EN 558 series 7, ISO 5752, basic series 7	58

5 Valve body material	Code
Cast iron material	
EN-GJL-250 (GG 25)	8
EN-GJL-250 (GG 25), hard rubber lined	13
EN-GJL-250 (GG 25), soft rubber lined	52
EN-GJL-250 (GG 25), butyl lined	58
SG iron material	
EN-GJS-500-7 (GGG-50), hard rubber lined	16

5 Valve body material	Code
EN-GJS-400-18-LT (GGG 40.3), soft rubber lined	82
EN-GJS-400-18-LT (GGG 40.3), hard rubber lined	83
EN-GJS-400-18-LT (GGG 40.3), butyl lined	88
EN-GJS-500-7 (GGG 50), soft rubber lined	92
EN-GJS-500-7 (GGG 50), butyl lined	98

6 Diaphragm material	Code
NBR	2
IIR	6
CR	8
EPDM	14
NR	15

7 Control function	Code
Manually operated	0

8 Actuator version	Code
Actuator size 2, for DN 25 and 40	2
Actuator size 4, for DN 50 and 65	4
Actuator size 6, for DN 80 and 100	6
Actuator size 7, for DN 125 and 150	7
Actuator size 8, for DN 200	8
Actuator size 9, for DN 250	9
Actuator size A, for DN 300 and 350	A

Order example

Order option	Code	Description
1 Type	655	Full bore diaphragm valve, manually operated, metal handwheel, metal bonnet
2 DN	50	DN 50
3 Body configuration	D	2/2-way body
4 Connection type	53	Flange EN 1092, PN 16, form A, face-to-face dimension FTF EN 558 series 7, ISO 5752, basic series 7
5 Valve body material	8	EN-GJL-250 (GG 25)
6 Diaphragm material	14	EPDM
7 Control function	0	Manually operated
8 Actuator version	4	Actuator size 4, for DN 50 and 65

Technical data

Medium

Working medium: Corrosive, inert, gaseous and liquid media which have no negative impact on the physical and chemical properties of the body and diaphragm material.

Temperature

Media temperature: 32 – 212 °F

Ambient temperature: 32 – 140 °F

Storage temperature: 32 – 104 °F

Pressure

Operating pressure:

MG	DN	NPS	Operating pressure
40	25	1"	0 - 145.0
	40	1½"	0 - 145.0
65	50	2"	0 - 145.0
	65	2½"	0 - 145.0
100	80	3"	0 - 145.0
	100	4"	0 - 145.0
150	125	5"	0 - 87.0
	150	6"	0 - 87.0
200	200	8"	0 - 50.0
250	250	10"	0 - 50.0
350	300	12"	0 - 45.0

MG = diaphragm size

All pressures are psi - gauge pressures. Operating pressure values were determined with static operating pressure applied on one side of a closed valve. Sealing at the valve seat and atmospheric sealing is ensured for the given values.

Information on operating pressures applied on both sides and for high purity media on request.

Valve not suitable for vacuum applications

Cv-values:

MG	DN	NPS	Kv values
40	25	1"	35
	40	1½"	38
65	50	2"	108
	65	2½"	114
100	80	3"	284
	100	4"	298
150	125	5"	650
	150	6"	680
200	200	8"	1790
250	250	10"	2920
350	300	12"	5180

MG = diaphragm size, Kv values in m³/h

Kv values determined in accordance with EN 60534, inlet pressure 5 bar, Δp 1 bar, valve body material cast iron EN-GJL-250 with connection flange EN 1092 length EN 558 series 7 and soft elastomer diaphragm. The Kv values for other product configurations (e.g. other diaphragm or body materials) may differ. In general, all diaphragms are subject to the influences of pressure, temperature, the process and their tightening torques. Therefore the Kv values may exceed the tolerance limits of the standard.

The Kv value curve (Kv value dependent on valve stroke) can vary depending on the diaphragm material and duration of use.

Product compliance

Pressure Equipment Directive: 2014/68/EU

EAC: TR CU 010/2011

Mechanical data

Weight:

Actuator

Actuator version	Weight
2	4.41
4	15.43
6	28.66
7	74.96
8	121.25
9	213.85
A	489.43

Weight in lb

Body

MG	DN	Weight
40	25	4.85
	40	11.90
65	50	13.89
	65	18.30
100	80	26.46
	100	37.70
150	125	62.61
	150	70.33
200	200	168.87
250	250	218.70
350	300	400.36

MG = diaphragm size
Weight in lb

Dimensions

Actuator dimensions

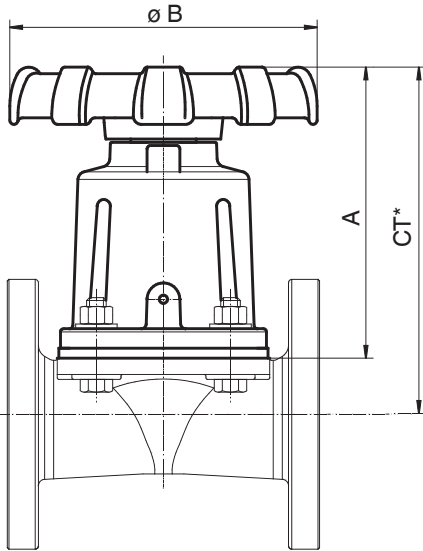

MG	DN	NPS	Actuator version	A	$\varnothing B$
40	25 - 40	1" - 1½"	2	5.12	4.65
65	50 - 65	2" - 2½"	4	7.01	7.40
100	80 - 100	3" - 4"	6	9.02	9.37
150	125 - 150	5" - 6"	7	12.09	12.44
200	200	8"	8	14.13	16.38
250	250	10"	9	19.06	16.38
350	300	12"	A	22.13	27.56

* CT = A + H1 (see body dimensions)

Dimensions in inch

Body dimensions

Flange EN (code 4)

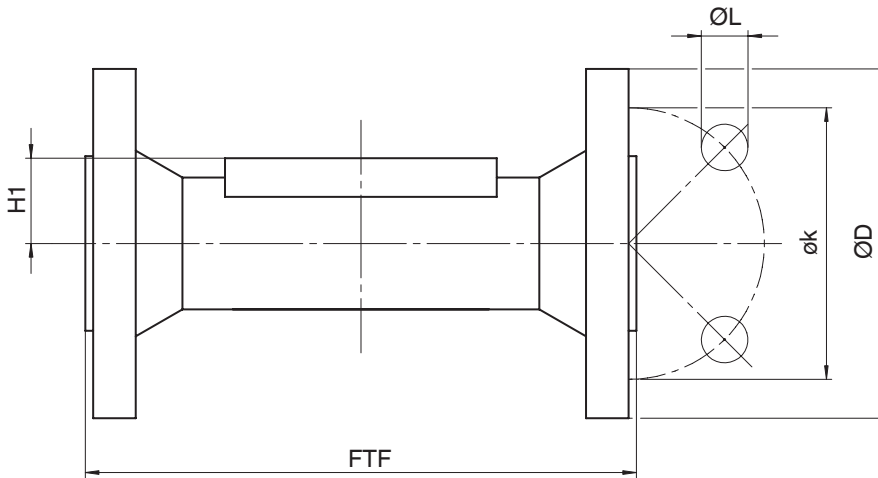

Connection type flange, length EN 558 (code 4)¹⁾, SG iron material (code 82, 83, 88)²⁾

MG	DN	NPS	øD	FTF	H1	øk	øL	n
200	200	8"	13.39	23.62	2.52	11.61	0.87	8

Dimensions in inch

MG = diaphragm size

n = number of bolts

1) Connection type

Code 4: Flange EN 1092, PN 10, form B, face-to-face dimension FTF EN 558 series 1, ISO 5752, basic series 1

2) Valve body material

Code 82: EN-GJS-400-18-LT (GGG 40.3), soft rubber lined

Code 83: EN-GJS-400-18-LT (GGG 40.3), hard rubber lined

Code 88: EN-GJS-400-18-LT (GGG 40.3), butyl lined

Flange EN (code 8)

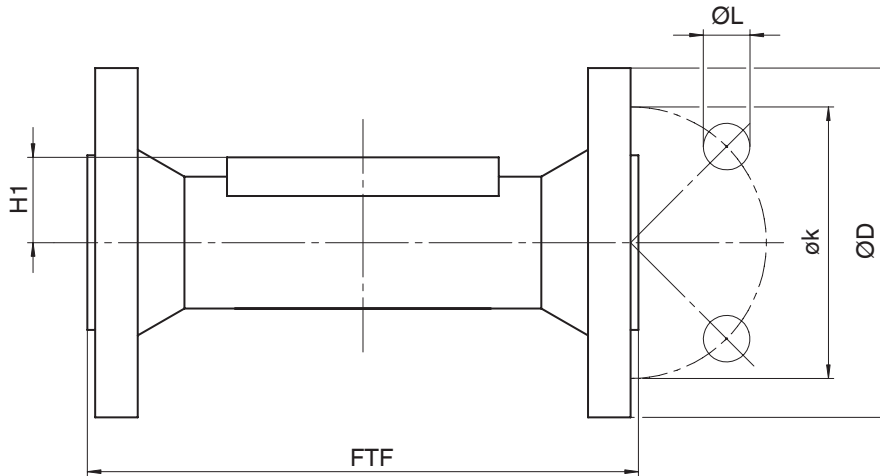

Connection type flange, length EN 558 (code 8)¹⁾, SG iron material (code 82, 83, 88)²⁾

MG	DN	NPS	øD	FTF	H1	øk	øL	n
40	25	1"	4.53	6.30	0.94	3.35	0.55	4
	40	1½"	5.91	7.87	0.94	4.33	0.71	4
65	50	2"	6.50	9.06	1.26	4.92	0.71	4
	65	2½"	7.28	11.42	1.26	5.71	0.71	4
100	80	3"	7.87	12.20	1.57	6.30	0.71	8
	100	4"	8.66	13.78	1.57	7.09	0.71	8
150	125	5"	9.84	15.75	2.17	8.27	0.71	8
	150	6"	11.22	18.90	2.17	9.45	0.87	8

Dimensions in inch

MG = diaphragm size

n = number of bolts

1) **Connection type**

Code 8: Flange EN 1092, PN 16, form B, face-to-face dimension FTF EN 558 series 1, ISO 5752, basic series 1

2) **Valve body material**

Code 82: EN-GJS-400-18-LT (GGG 40.3), soft rubber lined

Code 83: EN-GJS-400-18-LT (GGG 40.3), hard rubber lined

Code 88: EN-GJS-400-18-LT (GGG 40.3), butyl lined

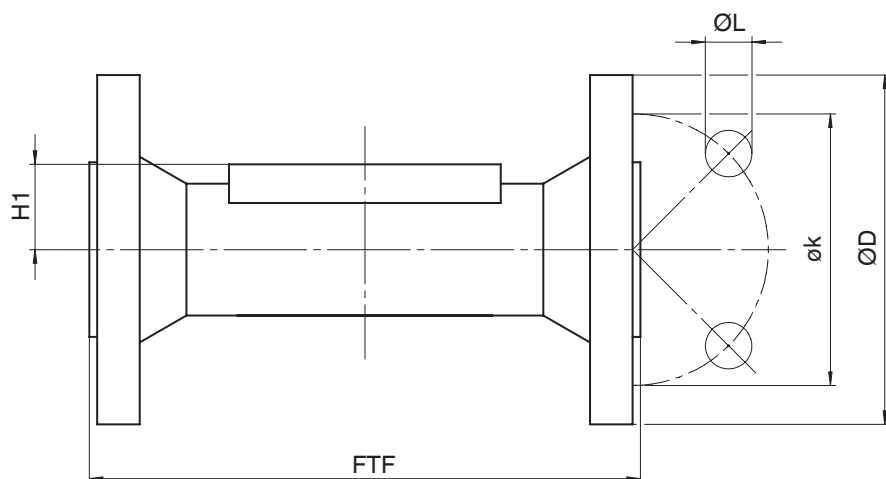
Flange EN (code 52)

Connection type flange, length EN 558 (code 52)¹⁾, cast iron material (code 8), SG iron material (code 16, 92, 98)²⁾

MG	DN	NPS	øD	FTF		H1	øk	øL	n
				Material		Material			
				8	16, 92, 98	8, 16, 92, 98			
200	200	8"	13.39	20.51	20.51	2.32	11.61	0.87	8

Connection type flange, length EN 558 (code 52)¹⁾, cast iron material (code 8, 13, 52, 58)²⁾

MG	DN	NPS	øD	FTF		H1	øk	øL	n
				Material		Material			
				8	13, 52, 58	8, 13, 52, 58			
250	250	10"	15.75	25.00	25.47	3.07	13.78	0.87	12
350	300	12"	17.91	29.49	29.96	4.69	15.75	0.87	12

Dimensions in inch

MG = diaphragm size

n = number of bolts

1) Connection type

Code 52: Flange EN 1092, PN 10, form A, face-to-face dimension FTF EN 558 series 7, ISO 5752, basic series 7

2) Valve body material

Code 8: EN-GJL-250 (GG 25)

Code 13: EN-GJL-250 (GG 25), hard rubber lined

Code 16: EN-GJS-500-7 (GGG-50), hard rubber lined

Code 52: EN-GJL-250 (GG 25), soft rubber lined

Code 58: EN-GJL-250 (GG 25), butyl lined

Code 92: EN-GJS-500-7 (GGG 50), soft rubber lined

Code 98: EN-GJS-500-7 (GGG 50), butyl lined

Flange EN (code 53)

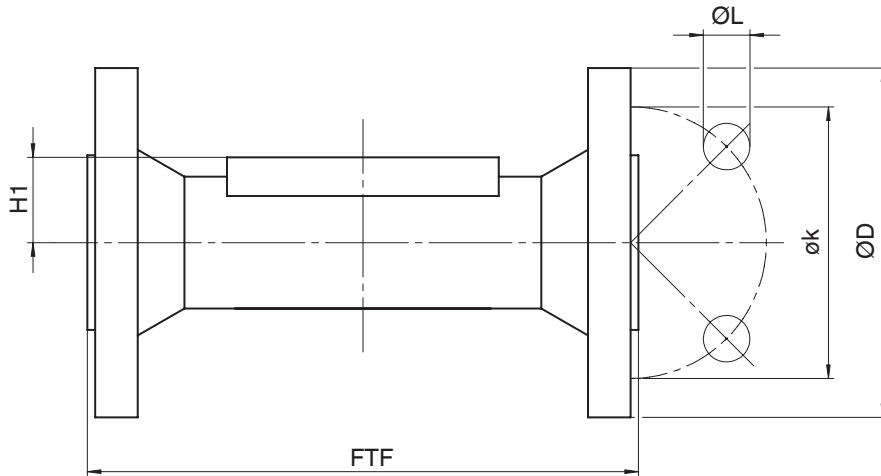

Connection type flange, length EN 558 (code 53)¹⁾, cast iron material (code 8), SG iron material (code 16, 92, 98)²⁾

MG	DN	NPS	øD	FTF		H1		øk	øL	n
				Material		Material				
				8	16, 92, 98	8	16, 92, 98			
40	25	1"	4.53	5.00	5.00	0.79	0.87	3.35	0.55	4
	40	1½"	5.91	6.26	6.26	0.71	0.94	4.33	0.71	4
65	50	2"	6.50	7.52	7.52	1.54	1.26	4.92	0.71	4
	65	2½"	7.28	8.50	8.50	1.10	1.26	5.71	0.71	4
100	80	3"	7.87	10.00	10.00	1.57	1.57	6.30	0.71	8
	100	4"	8.66	12.01	12.01	1.57	1.57	7.09	0.71	8
150	125	5"	9.84	14.02	14.41	1.97	2.17	8.27	0.71	8
	150	6"	11.22	15.98	15.98	2.05	2.17	9.45	0.87	8

MG = diaphragm size

Dimensions in inch

n = number of bolts

1) **Connection type**

Code 53: Flange EN 1092, PN 16, form A, face-to-face dimension FTF EN 558 series 7, ISO 5752, basic series 7

2) **Valve body material**

Code 8: EN-GJL-250 (GG 25)

Code 16: EN-GJS-500-7 (GGG-50), hard rubber lined

Code 92: EN-GJS-500-7 (GGG 50), soft rubber lined

Code 98: EN-GJS-500-7 (GGG 50), butyl lined

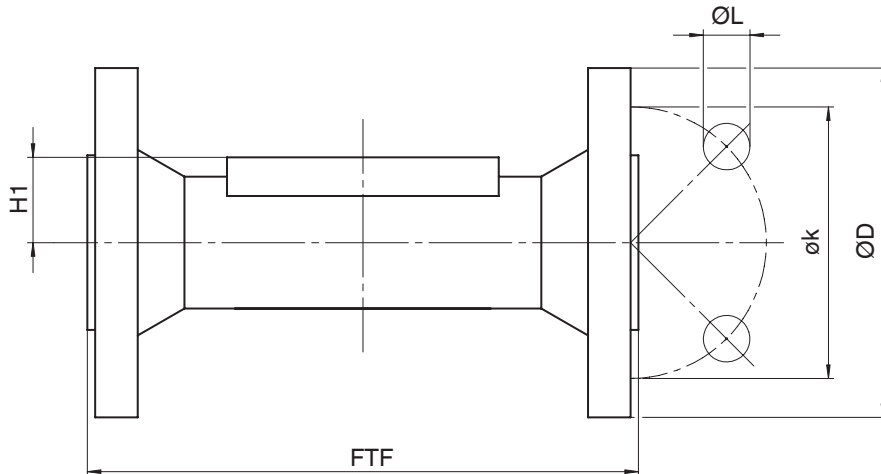
Flange ANSI Class (code 39)**Connection type flange, length EN 558 (code 39)¹⁾, SG iron material (code 82, 83, 88)²⁾**

MG	DN	NPS	øD	FTF	H1	øk	øL	n
40	25	1"	4.25	6.30	0.94	3.13	0.63	4
	40	1½"	5.00	7.87	0.94	3.87	0.63	4
65	50	2"	6.00	9.06	1.26	4.75	0.75	4
	65	2½"	7.00	11.42	1.26	5.50	0.75	4
100	80	3"	7.50	12.20	1.57	6.00	0.75	4
	100	4"	220,0 ³⁾	13.78	1.57	7.50	0.75	8
150	125	5"	10.00	15.75	2.17	8.50	0.87	8
	150	6"	10.98	18.90	2.17	9.50	0.87	8
200	200	8"	13.50	23.62	2.52	11.75	0.87	8

Dimensions in inch

MG = diaphragm size

n = number of bolts

1) Connection type

Code 39: Flange ANSI Class 125/150 RF, face-to-face dimension FTF EN 558 series 1, ISO 5752, basic series 1

2) Valve body material

Code 82: EN-GJS-400-18-LT (GGG 40.3), soft rubber lined

Code 83: EN-GJS-400-18-LT (GGG 40.3), hard rubber lined

Code 88: EN-GJS-400-18-LT (GGG 40.3), butyl lined

3) not according to ASME standard

Flange ANSI Class (code 58)

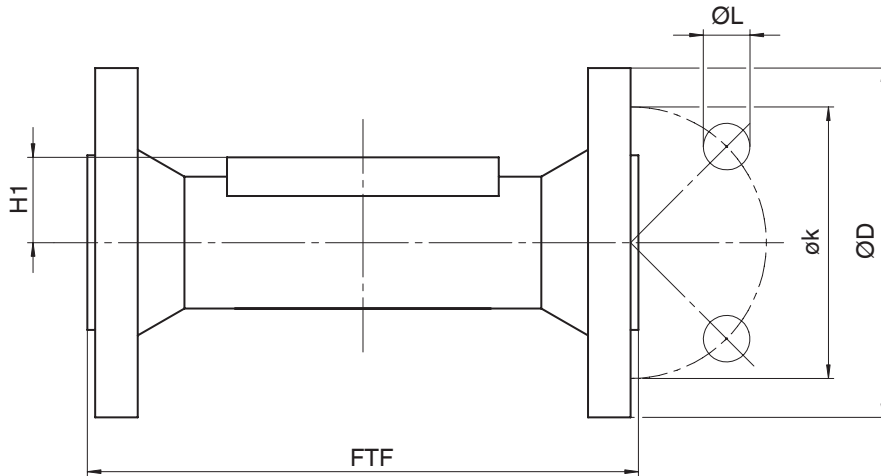

Connection type flange, length EN 558 (code 58)¹⁾, cast iron material (code 8), SG iron material (code 16, 92, 98)²⁾

MG	DN	NPS	øD	FTF		H1		øk	øL	n
				Material		Material				
				8	16, 92, 98	8	16, 92, 98			
40	25	1"	4.25	5.00	5.00	0.79	0.94	3.13	0.63	4
	40	1½"	5.00	6.26	6.26	0.71	0.94	3.87	0.63	4
65	50	2"	6.00	7.52	7.52	1.54	1.26	4.75	0.75	4
	65	2½"	7.00	8.50	8.50	1.10	1.26	5.50	0.75	4
100	80	3"	7.50	10.00	10.00	1.57	1.57	6.00	0.75	4
	100	4"	9.00	12.01	12.01	1.57	1.57	7.50	0.75	8
150	125	5"	10.00	14.02	14.41	1.97	2.17	8.50	0.87	8
	150	6"	10.98	15.98	15.98	2.05	2.17	9.50	0.87	8
200	200	8"	13.50	20.51	20.51	2.32	2.52	11.75	0.87	8

Connection type flange, length EN 558 (code 58)¹⁾, cast iron material (code 8, 13, 52, 58)²⁾

MG	DN	NPS	øD	FTF		H1		øk	øL	n
				Material		Material				
				8	13, 52, 58	8	13, 52, 58			
250	250	10"	15.98	25.00	25.47	3.07	2.83	14.25	1.00	12
350	300	12"	18.98	29.49	29.96	4.69	4.92	17.00	1.00	12

Dimensions in inch

MG = diaphragm size

n = number of bolts

1) **Connection type**

Code 58: Flange ANSI Class 125/150 FF, face-to-face dimension FTF EN 558 series 7, ISO 5752, basic series 7

2) **Valve body material**

Code 8: EN-GJL-250 (GG 25)

Code 13: EN-GJL-250 (GG 25), hard rubber lined

Code 16: EN-GJS-500-7 (GGG-50), hard rubber lined

Code 52: EN-GJL-250 (GG 25), soft rubber lined

Code 58: EN-GJL-250 (GG 25), butyl lined

Code 92: EN-GJS-500-7 (GGG 50), soft rubber lined

Code 98: EN-GJS-500-7 (GGG 50), butyl lined

Diaphragm dimensions

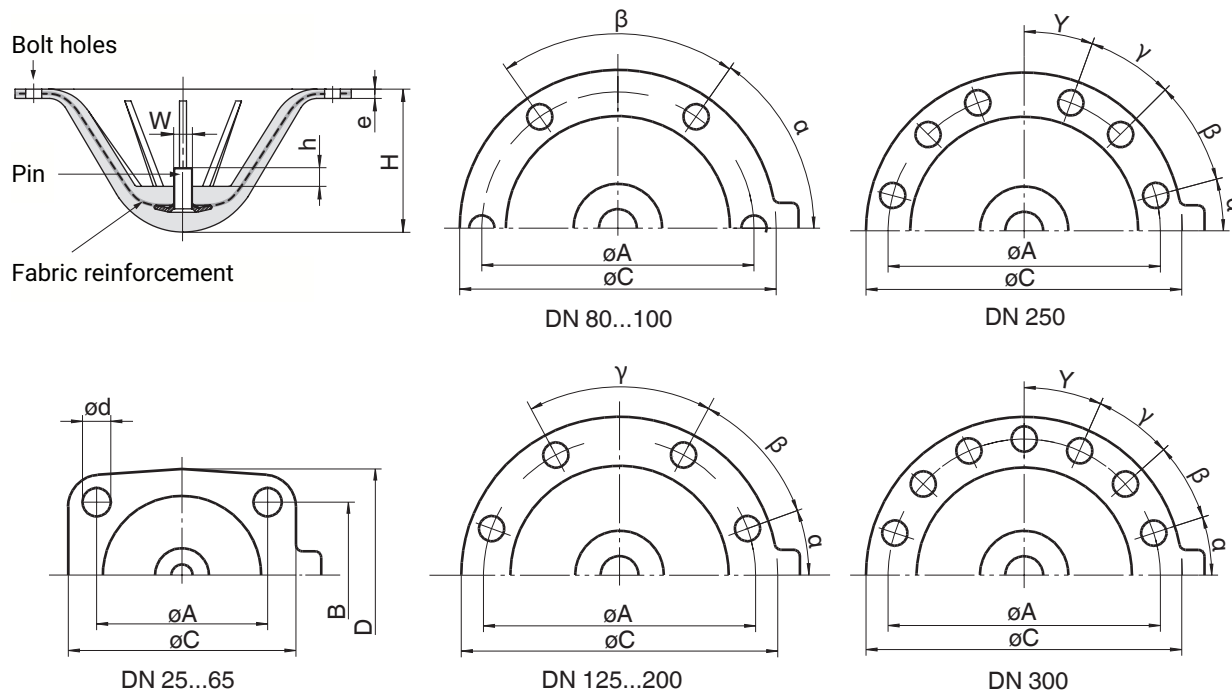

MG	DN	NPS	A	B	C	D	ød	e	h	W	H	α	β	γ	Y	n
40	25	1"	2.52	2.01	3.54	2.76	0.35	0.20	0.31	1/4"	1.42	-	-	-	-	4
	40	1 1/2"	2.52	2.01	3.54	2.76	0.35	0.20	0.31	1/4"	1.42	-	-	-	-	4
65	50	2"	3.98	3.23	6.26	5.04	0.53	0.24	0.39	5/16"	2.52	-	-	-	-	4
	65	2 1/2"	3.98	3.23	6.26	5.04	0.53	0.24	0.39	5/16"	2.52	-	-	-	-	4
100	80	3"	6.89	-	8.78	-	0.53	0.24	0.47	5/16"	3.15	56°	34°	-	-	6
	100	4"	6.89	-	8.78	-	0.53	0.24	0.47	5/16"	3.15	56°	34°	-	-	6
150	125	5"	10.04	-	11.30	-	0.53	0.31	0.63	5/8"	4.53	20°	40°	60°	-	8
	150	6"	10.04	-	11.30	-	0.53	0.31	0.63	5/8"	4.53	20°	40°	60°	-	8
200	200	8"	12.01	-	13.43	-	0.73	0.31	0.79	5/8"	5.71	30°	40°	40°	-	8
250	250	10"	15.00	-	16.14	-	0.67	0.39	0.79	5/8"	7.01	15°	30°	25°	20°	12
350	300	12"	20.79	-	22.68	-	0.87	0.47	0.98	1"	11.02	18°	24°	24°	24°	14

n = number of bolts

The thread of the diaphragm pin "W" corresponds to Whitworth standard.



GEMÜ Gebr. Müller Apparatebau GmbH & Co. KG
Fritz-Müller-Straße 6-8, 74653 Ingelfingen-Criesbach, Germany
Tel. +49 (0)7940 123-0 · info@gemue.de
www.gemu-group.com