

GEMÜ 675

Manually operated diaphragm valve



Features

- Suitable for particulate and abrasive media
- Various lining materials are available for a wide range of media
- Optische Stellungsanzeige serienmäßig integriert

Description

The GEMÜ 675 2/2-way diaphragm valve has a metal handwheel and is manually operated. An integral optical position indicator is standard.

Technical specifications

- **Media temperature:** 14 to 212 °F
 - **Ambient temperature:** 32 to 140 °F
 - **Operating pressure :** 0 to 150 psi
 - **Nominal sizes:** 1/2" (DN 15) to 6" (DN 150)
 - **Body configurations:** 2/2-way body
 - **Connection standards:** ANSI | BS | DIN | EN
 - **Body materials:** EN-GJL-250, cast iron material | EN-GJS-400-18-LT, SG iron material | EN-GJS-400-18-LT, SG iron material with hard rubber lining | EN-GJS-400-18-LT, SG iron material, PFA lined | EN-GJS-400-18-LT, SG iron material, PP lined | EN-GJS-500-7, ductile iron material, PFA lined | EN-GJS-500-7, ductile iron material, PP lined
 - **Body lining:** Hard rubber | PFA | PP
 - **Diaphragm materials:** CR | EPDM | FKM | NBR | PTFE/EPDM | PTFE/FKM | PTFE/PVDF/EPDM
 - **Conformities:** CRN | EAC | FDA | Reg. (EU) No. 10/2011 | Regulation (EC) No. 1935/2004 | TA Luft (German Clean Air Act)
- Technical data depends on the respective configuration



Product description

Construction

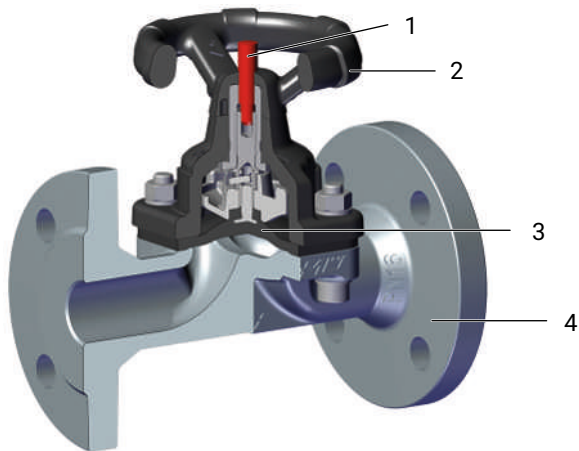

Item	Name	Materials
1	Optical position indicator	PP red
2	Actuator	Cast iron
3	Diaphragm	NBR FKM CR EPDM PTFE / EPDM (one-piece) PTFE / EPDM (two-piece) PTFE / FKM (two-piece) PTFE / PVDF / EPDM (three-piece)
4	Valve body	EN-GJL-250 (GG 25) EN-GJS-400-18-LT (GGG 40.3) EN-GJS-400-18-LT (GGG 40.3), PFA lined EN-GJS-400-18-LT (GGG 40.3), PP lined EN-GJS-400-18-LT (GGG 40.3), hard rubber lined EN-GJS-500-7 (GGG 50), PFA lined EN-GJS-500-7 (GGG 50), PP lined

Availability

Availability of valve bodies

Threaded connection, flange

MG	DN	Threaded connection	Flange																		
			Connection types code ¹⁾																		
			1, 31	8			38			39			51		53		56				
			Material code ²⁾																		
	90	90	17	18	83	17	18 ³⁾	83	90	17	18	83	17	81	91 ³⁾	8	17	17	81	91 ³⁾	
25	15	X	X	X	X	X	-	-	-	X	X	X	X	-	-	-	X	-	-	-	-
	20	X	X	X	X	X	X	X	X	X	X	X	X	-	-	-	X	-	-	-	-
	25	X	X	X	X	X	X	X	X	X	X	X	X	-	X	X	X	-	-	X	X
40	32	X	X	X	X	X	-	-	-	X	X	X	X	-	-	-	-	-	-	-	-
	40	X	X	X	X	X	X	X	X	X	X	X	X	-	X	X	X	-	-	X	X
50	50	X	X	X	X	X	X	X	X	X	X	X	X	-	X	X	X	-	-	X	X
	65	-	X	-	-	-	-	-	-	X	-	-	-	-	-	-	-	-	-	-	-
65	65	-	-	X	X	X	X	X	X	-	X	X	X	-	-	-	X	-	-	-	-
80	80	-	X	X	X	X	X	X	X	X	X	X	X	-	X	X	X	-	-	X	X
100	100	-	X	X	X	X	X	X	X	X	X	X	X	-	X	X	X	-	-	X	X
	125	-	X	-	-	-	-	-	-	X	-	-	-	-	-	-	-	-	-	-	-
125	125	-	-	X	-	X	-	-	-	-	X	-	X	-	-	-	X	-	-	-	-
150	150	-	X	X	-	X	X	-	X	X	X	-	X	X	-	-	X	X	X	-	-

MG = diaphragm size

X = Standard

1) Connection type

Code 1: Threaded socket DIN ISO 228

Code 8: Flange EN 1092, PN 16, form B, face-to-face dimension FTF EN 558 series 1, ISO 5752, basic series 1, length only for body configuration D

Code 31: NPT female thread

Code 38: Flange ANSI Class 150 RF, length only for body configuration D acc. to MSS SP-88

Code 39: Flange ANSI Class 125/150 RF, length only for body configuration D acc. to EN 558 series 1, ISO 5752, basic series 1

Code 51: Flange BS 10 Table E, face-to-face dimension FTF EN 558 series 7, ISO 5752, basic series 7, length only for body configuration D

Code 53: Flange EN 1092, PN 16, form A, face-to-face dimension FTF EN 558 series 7, ISO 5752, basic series 7, length only for body configuration D

Code 56: Flange ANSI Class 125/150 RF, face-to-face dimension FTF EN 558 series 7, ISO 5752, basic series 7, length only for body configuration D

2) Valve body material

Code 8: EN-GJL-250 (GG 25)

Code 17: EN-GJS-400-18-LT (GGG 40.3), PFA lined

Code 18: EN-GJS-400-18-LT (GGG 40.3), PP lined

Code 81: EN-GJS-500-7 (GGG 50), PFA lined

Code 83: EN-GJS-400-18-LT (GGG 40.3), hard rubber lined

Code 90: EN-GJS-400-18-LT (GGG 40.3)

Code 91: EN-GJS-500-7 (GGG 50), PP lined

3) on request

Availability of actuator version

MG	DN	Actuator version
25	15 – 25	0
40	32 – 40	1
50	50 – 65	2

Availability

MG	DN	Actuator version
65	65	3
80	80	4
100	100 – 125	5
125	125	6
150	150	7

Order data

The order data provide an overview of standard configurations.

Please check the availability before ordering. Other configurations available on request.

Order codes

1 Type	Code
Diaphragm valve, manually operated, metal handwheel, metal distance piece, optical position indicator	675

2 DN	Code
DN 15	15
DN 20	20
DN 25	25
DN 32	32
DN 40	40
DN 50	50
DN 65	65
DN 80	80
DN 100	100
DN 125	125
DN 150	150

3 Body configuration	Code
2/2-way body	D

4 Connection type	Code
Threaded socket DIN ISO 228	1
NPT female thread	31
Flange	
Flange EN 1092, PN 16, form B, face-to-face dimension FTF EN 558 series 1, ISO 5752, basic series 1, length only for body configuration D	8
Flange ANSI Class 150 RF, length only for body configuration D acc. to MSS SP-88	38
Flange ANSI Class 125/150 RF, length only for body configuration D acc. to EN 558 series 1, ISO 5752, basic series 1	39
Flange BS 10 Table E, face-to-face dimension FTF EN 558 series 7, ISO 5752, basic series 7, length only for body configuration D	51
Flange EN 1092, PN 16, form A, face-to-face dimension FTF EN 558 series 7, ISO 5752, basic series 7, length only for body configuration D	53
Flange ANSI Class 125/150 RF, face-to-face dimension FTF EN 558 series 7, ISO 5752, basic series 7, length only for body configuration D	56

5 Valve body material	Code
Cast iron material	
EN-GJL-250 (GG 25)	8

5 Valve body material	Code
SG iron material	
EN-GJS-400-18-LT (GGG 40.3), PFA lined	17
EN-GJS-400-18-LT (GGG 40.3), PP lined	18
EN-GJS-500-7 (GGG 50), PFA lined	81
EN-GJS-400-18-LT (GGG 40.3), hard rubber lined	83
EN-GJS-400-18-LT (GGG 40.3)	90
EN-GJS-500-7 (GGG 50), PP lined	91

6 Diaphragm material	Code
Elastomer	
NBR	2
FKM	4
CR	8
EPDM	29
PTFE	
PTFE/EPDM one-piece	54
PTFE/EPDM two-piece	5M
PTFE/FKM two-piece	5T
PTFE/PVDF/EPDM three-piece	71
Note: The PTFE/PVDF/EPDM diaphragm (code 71) can only be combined with PFA lined valve bodies.	

7 Control function	Code
Manually operated	0
Manually operated, with lockable handwheel	L
Manually operated with lockable handwheel, (without proprietary padlock)	B

Order data

8 Actuator version	Code
Clamp	
Actuator size 0	0
Clamp	
Actuator size 1	1
Clamp	
Actuator size 2	2
Clamp	
Actuator size 3	3

8 Actuator version	Code
Clamp	
Actuator size 4	4
Clamp	
Actuator size 5	5
Clamp	
Actuator size 6	6
Clamp	
Actuator size 7	7

Order example

Order option	Code	Description
1 Type	675	Diaphragm valve, manually operated, metal handwheel, metal distance piece, optical position indicator
2 DN	50	DN 50
3 Body configuration	D	2/2-way body
4 Connection type	8	Flange EN 1092, PN 16, form B, face-to-face dimension FTF EN 558 series 1, ISO 5752, basic series 1, length only for body configuration D
5 Valve body material	90	EN-GJS-400-18-LT (GGG 40.3)
6 Diaphragm material	29	EPDM
7 Control function	0	Manually operated
8 Actuator version	2	Actuator size 2

Technical data

Medium

Working medium: Corrosive, inert, gaseous and liquid media which have no negative impact on the physical and chemical properties of the body and diaphragm material.

Temperature

Media temperature:

NBR (code 2)	14 – 212 °F
FKM (code 4)	14 – 194 °F
CR (code 8)	14 – 212 °F
EPDM (code 29)	14 – 212 °F
PTFE / EPDM (code 54)	14 – 212 °F
PTFE / EPDM (code 5M)	14 – 212 °F
PTFE / FKM (code 5T)	14 – 212 °F
PTFE / PVDF / EPDM (code 71)	14 – 212 °F

Ambient temperature: 32 – 140 °F

Storage temperature: 32 – 104 °F

Pressure

Operating pressure:

MG	DN	EPDM	PTFE
25	15 - 25	0 - 150	0 - 90
40	32 - 40	0 - 150	0 - 90
50	50 - 65	0 - 150	0 - 90
65	65	0 - 150	0 - 90
80	80	0 - 150	0 - 90
100	100 - 125	0 - 150	0 - 90
125	125	0 - 150	0 - 90
150	150	0 - 120	0 - 75

MG = diaphragm size

All pressures are psi - gauge pressures. Operating pressure values were determined with static operating pressure applied on one side of a closed valve. Sealing at the valve seat and atmospheric sealing is ensured for the given values.

Information on operating pressures applied on both sides and for high purity media on request.

Pressure rating: PN 16

Leakage rate: Leakage rate A (acc. to EN 12266-1)

Leakage rate:

MG	DN	SG iron 40.3 connection type 1, 31	SG iron 40.3 connection type 8, 39	PFA / PP	Hard rubber
25	15	8.0	10.0	5.0	6.0
	20	11.5	14.0	9.0	11.0
	25	11.5	17.0	13.0	15.0
40	32	28.0	36.0	23.0	29.0
	40	28.0	40.0	26.0	32.0
50	50	60.0	68.0	47.0	64.0
	65	-	68.0	-	-
65	65	-	-	72.0	80.0
80	80	-	130.0	110.0	128.0
100	100	-	200.0	177.0	190.0
	125	-	200.0	-	-
125	125	-	-	214.0	230.0
150	150	-	484.0	365.0	397.0

MG = diaphragm size, Kv values in m³/h

Kv values determined in accordance with DIN EN 60534, inlet pressure 5 bar, Δp 1 bar, with connection flange EN 1092 length EN 558 series 1 (or threaded socket DIN ISO 228 for body material GGG40.3) and soft elastomer diaphragm. The Kv values for other product configurations (e.g. other diaphragm or body materials) may differ. In general, all diaphragms are subject to the influences of pressure, temperature, the process and their tightening torques. Therefore the Kv values may exceed the tolerance limits of the standard.

The Kv value curve (Kv value dependent on valve stroke) can vary depending on the diaphragm material and duration of use.

Product compliance

Pressure Equipment Directive: 2014/68/EU

Food: FDA*
Regulation (EC) No. 1935/2004
Regulation (EC) No. 10/2011*

EAC: TR CU 010/2011

TA Luft (German Clean Air Act): USP
USP

* see availability

Mechanical data

Weight:

Body

MG	DN	Threaded socket	Flange
		Connection types code	
		1, 31	8, 38, 39, 51, 53, 56
25	15	1.10	3.31
	20	1.32	4.85
	25	1.98	6.17
40	32	3.09	7.50
	40	4.19	9.92
50	50	5.95	13.89
	65	-	22.71
80	80	-	30.42
100	100	-	45.86
	125	-	57.98
150	150	-	82.23

Installation position:

Optional

Flow direction:

Optional

Actuator

Actuator version	Weight
0	2.43
1	4.63
2	5.95
3	13.01
4	20.94
5	26.46
6	33.07
7	55.12

Dimensions

Actuator dimensions

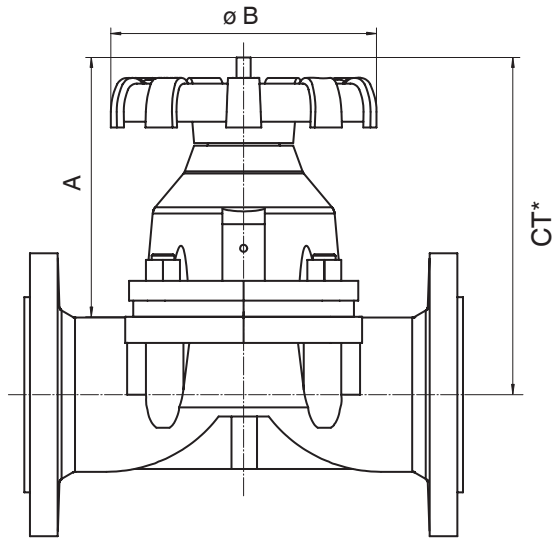

MG	DN	Actuator version	ø B	A
25	15 - 25	0	3.78	3.50
40	32 - 40	1	5.16	4.41
50	50 - 65	2	5.16	4.96
65	65	3	7.40	6.73
80	80	4	9.09	7.95
100	100 - 125	5	9.09	8.70
125	125	6	12.44	11.81
150	150	7	12.44	12.80

MG = diaphragm size

Dimensions in inch

* CT = A + H1 (see body dimensions)

Body dimensions

Flange EN (code 8)

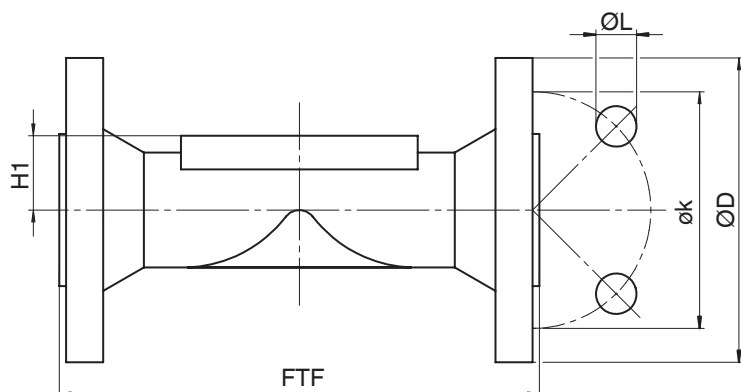

MG	DN	Connection type code 8 ¹⁾							
		Material code ²⁾				17, 18, 83	90	17, 18, 83	90
		øD	øk	øL	n	H1	H1	FTF	FTF
25	15	3.74	2.56	5.51	4	7.09	0.55	5.12	5.12
	20	4.18	2.95	5.51	4	8.07	0.65	5.91	5.91
	25	4.53	3.35	5.51	4	9.06	0.77	6.30	6.30
40	32	5.51	3.94	7.48	4	11.3	0.91	7.09	7.09
	40	5.91	4.33	7.48	4	12.99	1.06	7.87	7.87
50	50	6.50	4.92	7.48	4	15.35	1.26	9.06	9.06
	65	7.28	5.71	19.0	4	-	1.52	-	11.42
65	65	7.28	5.71	7.48	4	20.08	-	11.42	-
80	80	7.87	6.30	7.48	8	23.43	1.24	12.20	12.20
100	100	8.66	7.09	7.48	8	28.74	1.69	13.78	13.78
	125	9.84	8.27	19.0	8	-	2.28	-	15.75
125	125	9.84	8.27	7.48	8	34.25	-	15.75	-
150	150	11.22	9.45	9.06	8	42.91	2.28	18.90	18.90

n = number of bolts

MG = diaphragm size

1) Connection type

Code 8: Flange EN 1092, PN 16, form B, face-to-face dimension FTF EN 558 series 1, ISO 5752, basic series 1, length only for body configuration D

2) Valve body material

Code 17: EN-GJS-400-18-LT (GGG 40.3), PFA lined

Code 18: EN-GJS-400-18-LT (GGG 40.3), PP lined

Code 83: EN-GJS-400-18-LT (GGG 40.3), hard rubber lined

Code 90: EN-GJS-400-18-LT (GGG 40.3)

Flange EN (code 53)

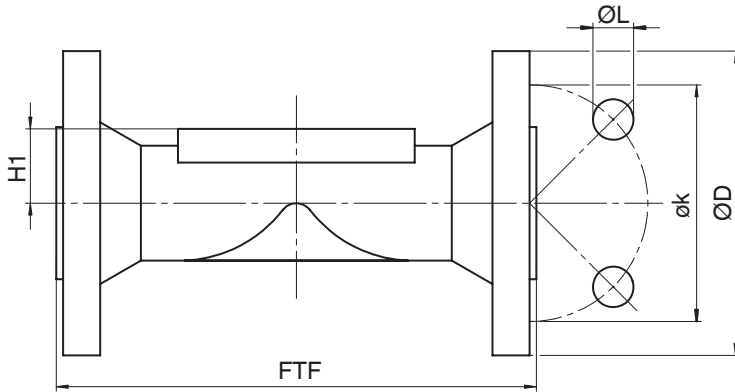

MG	DN	Connection type code 53 ¹⁾								
		Material code ²⁾								
		8	17				8	17	8	17
		øD	øD	øk	øL	n	H1	H1	FTF	FTF
25	15	3.74	-	2.56	5.51	4	7.48	-	4.61	-
	20	4.18	-	2.95	5.51	4	7.48	-	4.61	-
	25	4.53	-	3.35	5.51	4	7.48	-	5.00	-
40	32	5.51	-	3.94	7.48	4	11.02	-	-	-
	40	5.91	-	4.33	7.48	4	11.02	-	6.26	-
50	50	6.50	-	4.92	7.48	4	13.78	-	7.52	-
65	65	7.28	-	5.71	7.48	4	10.83	-	8.50	-
80	80	7.87	-	6.30	7.48	8	12.99	-	10.00	-
100	100	8.66	-	7.09	7.48	8	16.93	-	12.01	-
125	125	9.84	-	8.27	7.48	8	25.59	-	14.02	-
150	150	11.22	110.24 ³⁾	9.45	9.06	8	22.83	4.29	15.98	16.38

n = number of bolts

MG = diaphragm size

Dimensions in inch

1) **Connection type**

Code 53: Flange EN 1092, PN 16, form A, face-to-face dimension FTF EN 558 series 7, ISO 5752, basic series 7, length only for body configuration D

2) **Valve body material**

Code 8: EN-GJL-250 (GG 25)

Code 17: EN-GJS-400-18-LT (GGG 40.3), PFA lined

3) Diameter deviates from standard

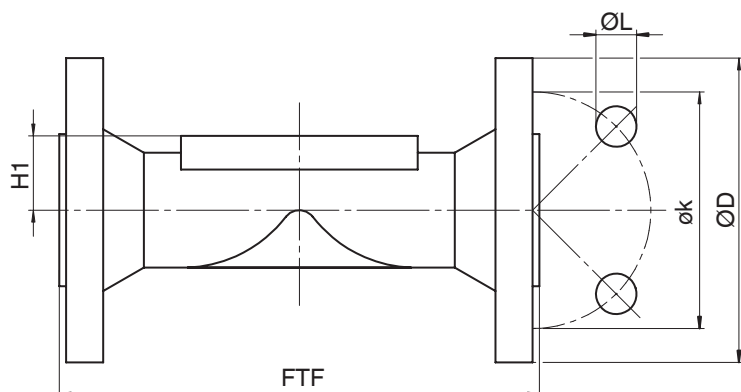
Flange ANSI Class (code 38, 39)

MG	DN	Connection types code ¹⁾											
								38	38	39	39		
								Material code ²⁾					
								17, 18, 83	90	17, 18	83	17, 18, 83	90
		øD	øk	øL	n	H1	H1	FTF	FTF	FTF	FTF		
25	15	3.54	2.37	6.26	4	7.09	0.55	-	-	5.12	5.12		
	20	3.94	2.75	6.26	4	8.07	0.65	5.75	5.76	5.91	5.91		
	25	4.33	3.13	6.26	4	9.06	0.77	5.75	5.76	6.30	6.30		
40	32	4.53	3.50	6.26	4	11.3	0.91	-	-	7.09	7.09		
	40	4.92	3.87	6.26	4	12.99	1.06	6.89	6.75	7.87	7.87		
50	50	5.91	4.75	7.48	4	15.35	1.26	7.87	7.77	9.06	9.06		
	65	7.09	5.50	19.0	4	-	1.52	-	-	-	11.42		
65	65	7.09	5.50	7.48	4	20.08	-	8.90	8.76	11.42	-		
80	80	7.48	6.00	7.48	4	23.43	1.24	10.24	10.25	12.20	12.20		
100	100	9.06	7.50	7.48	8	28.74	1.69	12.87	12.77	13.78	13.78		
	125	10.04	8.50	22.2	8	-	2.28	-	-	-	15.75		
125	125	10.04	8.50	8.74	8	34.25	-	-	-	15.75	-		
150	150	11.02	9.50	8.74	8	42.91	2.28	16.38	16.38	18.90	18.90		

n = number of bolts

MG = diaphragm size

Dimensions in inch

1) Connection type

Code 38: Flange ANSI Class 150 RF, length only for body configuration D acc. to MSS SP-88

Code 39: Flange ANSI Class 125/150 RF, length only for body configuration D acc. to EN 558 series 1, ISO 5752, basic series 1

2) Valve body material

Code 17: EN-GJS-400-18-LT (GGG 40.3), PFA lined

Code 18: EN-GJS-400-18-LT (GGG 40.3), PP lined

Code 83: EN-GJS-400-18-LT (GGG 40.3), hard rubber lined

Code 90: EN-GJS-400-18-LT (GGG 40.3)

Flange ANSI Class (code 56)

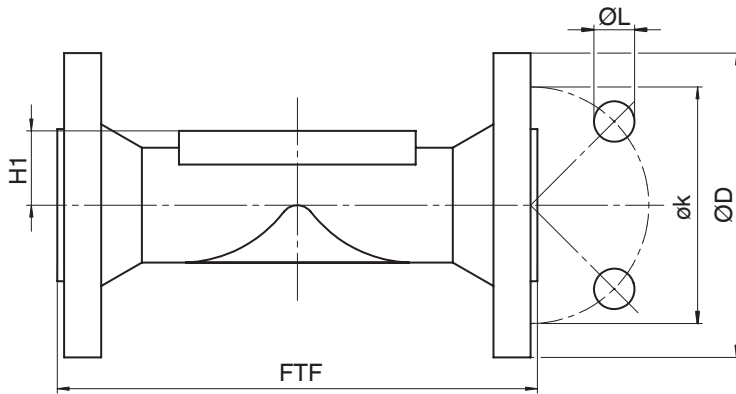

MG	DN	Connection type code 56 ¹⁾							
		Material code ²⁾				17	81, 91	17	81, 91
		øD	øk	øL	n	H1	H1	FTF	FTF
25	25	4.33	3.13	6.26	4	-	0.91	-	5.0
40	40	4.92	3.87	6.26	4	-	1.26	-	6.50
50	50	5.91	4.75	7.48	4	-	1.57	-	7.52
80	80	7.48	6.00	7.48	4	-	2.28	-	10.0
100	100	9.06	7.50	7.48	8	-	2.76	-	12.24
150	150	11.02	9.50	8.74	8	4.29	-	16.38	-

n = number of bolts
 MG = diaphragm size
 Dimensions in inch

1) **Connection type**

Code 56: Flange ANSI Class 125/150 RF, face-to-face dimension FTF EN 558 series 7, ISO 5752, basic series 7, length only for body configuration D

2) **Valve body material**

Code 17: EN-GJS-400-18-LT (GGG 40.3), PFA lined
 Code 81: EN-GJS-500-7 (GGG 50), PFA lined
 Code 91: EN-GJS-500-7 (GGG 50), PP lined

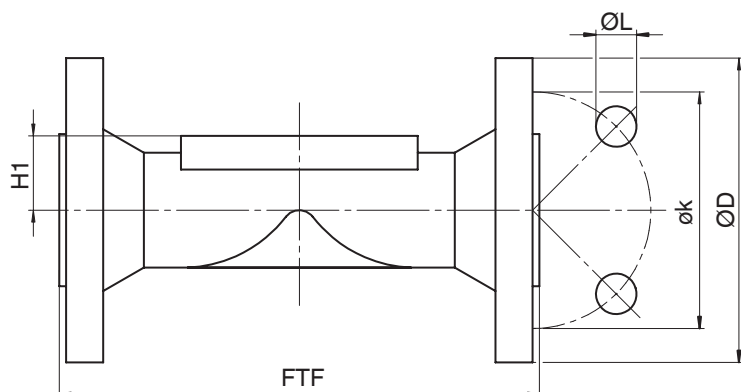
Flange BS (code 51)

MG	DN	Connection type code 51 ¹⁾							
		Material code ²⁾				17	81, 91	17	81, 91
		øD	øk	øL	n	H1	H1	FTF	FTF
25	25	4.49	3.27	5.51	4	-	0.91	-	5.0
40	40	4.92	3.86	5.51	4	-	1.26	-	6.50
50	50	5.98	4.49	6.69	4	-	1.57	-	7.52
80	80	7.24	5.75	6.69	4	-	2.28	-	10.0
100	100	8.50	7.01	6.69	8	-	2.76	-	12.24
150	150	10.98	9.25	8.66	8	4.29	-	16.38	-

n = number of bolts

MG = diaphragm size

Dimensions in inch

1) **Connection type**

Code 51: Flange BS 10 Table E, face-to-face dimension FTF EN 558 series 7, ISO 5752, basic series 7, length only for body configuration D

2) **Valve body material**

Code 17: EN-GJS-400-18-LT (GGG 40.3), PFA lined

Code 81: EN-GJS-500-7 (GGG 50), PFA lined

Code 91: EN-GJS-500-7 (GGG 50), PP lined

Threaded socket DIN (code 1)

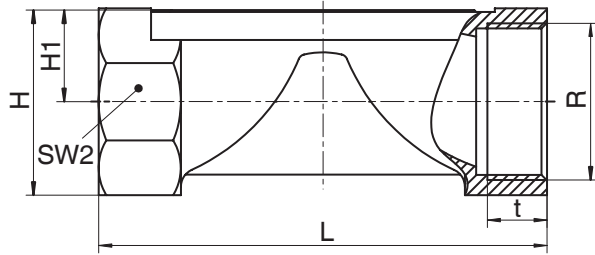

Connection type threaded socket (code 1)¹⁾, SG iron material (code 90)²⁾

MG	DN	NPS	H	H1	L	n	R	SW 2	t
25	15	1/2"	1.29	0.66	3.35	6	G 1/2	32	0.59
	20	3/4"	1.65	0.85	3.35	6	G 3/4	41	0.64
	25	1"	1.84	0.93	4.33	6	G 1	46	0.75
40	32	1 1/4"	2.20	1.12	4.72	6	G 1 1/4	55	0.84
	40	1 1/2"	2.60	1.32	5.51	6	G 1 1/2	65	0.84
50	50	2"	2.99	1.52	6.50	6	G 2	75	1.01

n = number of flats
 MG = diaphragm size
 Dimensions in inch

- 1) **Connection type**
Code 1: Threaded socket DIN ISO 228
- 2) **Valve body material**
Code 90: EN-GJS-400-18-LT (GGG 40.3)

Threaded socket NPT (code 31)

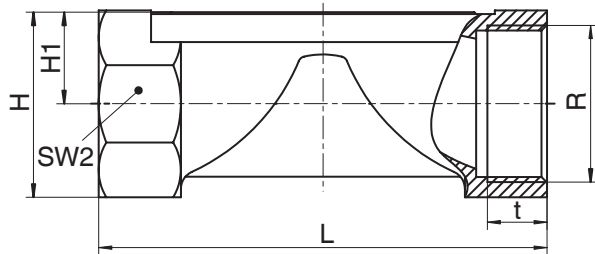

Connection type threaded socket NPT (code 31)¹⁾, SG iron material (code 90)²⁾

MG	DN	NPS	H	H1	L	n	R	SW 2	t
25	15	1/2"	1.29	0.66	3.35	6	NPT 1/2	32	0.54
	20	3/4"	1.65	0.85	3.35	6	NPT 3/4	41	0.56
	25	1"	1.84	0.93	4.33	6	NPT 1	46	0.66
40	32	1 1/4"	2.20	1.12	4.72	6	NPT 1 1/4	55	0.68
	40	1 1/2"	2.60	1.32	5.51	6	NPT 1 1/2	65	0.68
50	50	2"	2.99	1.52	6.50	6	NPT 2	75	0.70

n = number of flats
 Dimensions in inch
 MG = diaphragm size

- 1) **Connection type**
Code 31: NPT female thread
- 2) **Valve body material**
Code 90: EN-GJS-400-18-LT (GGG 40.3)



GEMÜ Gebr. Müller Apparatebau GmbH & Co. KG
Fritz-Müller-Straße 6-8, 74653 Ingelfingen-Criesbach, Germany
Tel. +49 (0)7940 123-0 · info@gemue.de
www.gemu-group.com