

GEMÜ BB04

Ball valve with bare shaft



Features

- Checked delta ferrite material < 3% (1.4435)
- Material certificates for media wetted components
- Media wetted surfaces according to ASME SF5 (Ra 0.51 µm)
- Butt weld spigots in extended orbital welding design
- Optionally available with cavity-filled seat
- Suitable for vacuum applications
- Option: ATEX version
- Ball valve body, assembled free of oil/grease

Description

The three-piece 2/2-way GEMÜ BB04 metal ball valve with a bare shaft and an actuator flange in accordance with DIN ISO 5211 for simple mounting of various actuator types is particularly suited to applications in the supply sector for the pharmaceutical, foodstuffs processing and biotechnology (such as water treatment and steam generation) industries thanks to the 1.4435 stainless steel alloy material composition used (compliant with 316L) with a low delta ferrite proportion of < 3%. Only those plastics which are compliant with FDA, USP Class VI and Regulation (EU) No.10/2011 are used for the seals.

Technical specifications

- **Media temperature:** -10 to 220 °C
- **Ambient temperature:** -20 to 60 °C
- **Operating pressure :** 0 to 63 bar
- **Nominal sizes:** 1/4" (DN 8) to 4" (DN 100)
- **Body configurations:** 2/2-way body
- **Connection type:** Clamp | Spigot
- **Connection standards:** ASME | DIN | ISO | SMS
- **Body materials:** 1.4435 (316L), investment casting material
- **Seal materials:** PTFE
- **Conformities:** ATEX | EAC | FDA | Reg. (EU) No. 10/2011 | Regulation (EC) No. 1935/2004 | TA Luft (German Clean Air Act) | USP

Technical data depends on the respective configuration



further information
webcode: GW-BB04



Product line

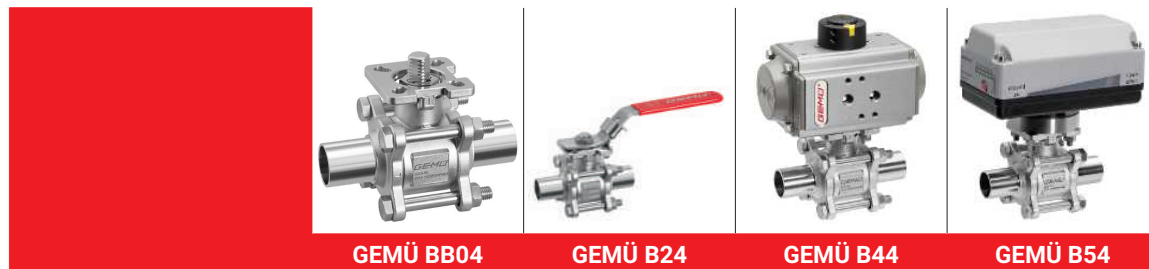

| | GEMÜ BB04 | GEMÜ B24 | GEMÜ B44 | GEMÜ B54 |
|---------------------------|---------------|---------------|---------------|---------------|
| Operation | | | | |
| With bare shaft | ● | - | - | - |
| Manual | - | ● | - | - |
| Pneumatic | - | - | ● | - |
| Motorized | - | - | - | ● |
| Nominal sizes | DN 8 to 100 | DN 8 to 100 | DN 8 to 100 | DN 8 to 100 |
| Media temperature | -10 to 220 °C | -10 to 220 °C | -10 to 220 °C | -10 to 220 °C |
| Operating pressure | 0 to 63 bar | 0 to 63 bar | 0 to 63 bar | 0 to 63 bar |
| Connection types | | | | |
| Clamp | ● | ● | ● | ● |
| Spigot | ● | ● | ● | ● |

Product description

Construction

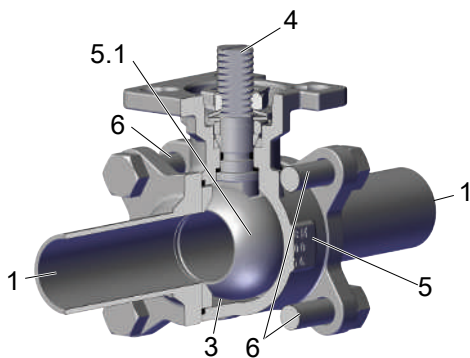

| Item | Name | Materials |
|------|------------------|-------------------------|
| 5 | Ball valve body | ASTM A351/1.4435 (316L) |
| 1 | Pipe connections | ASTM A351/1.4435 (316L) |
| 5.1 | Ball | ASTM A351/1.4435 (316L) |
| 4 | Ball valve shaft | 1.4409 (SS316L) |
| 6 | Bolt | A2 70 |
| 3 | Seals | PTFE |

Cavity-filled PTFE seal (Code 5H)



- The cavity-filled seal, which is made of PTFE, is specially designed to reduce excess volumes in the ball cavity.
- Media that remains in the valve's dead spaces is unwanted during food production, for example, and may decontaminate this.
- These deposits accumulate and contaminate the entire process. Thanks to this special seal variant, the volume in the ball cavity is reduced to a minimum.

Application

- Water treatment
- Steam processing
- CIP/SIP
- Waste water treatment
- Storage and distribution
- Drying

The spindle seal system

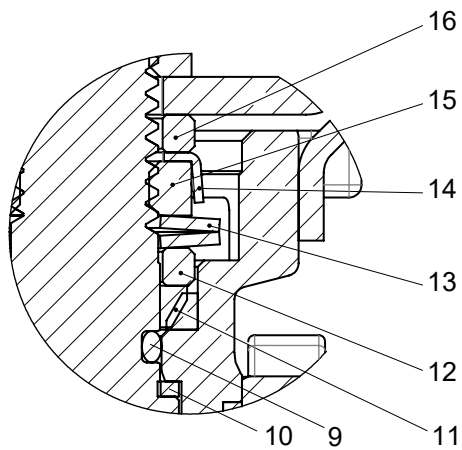

| Item | Name | Material |
|------|------------------------|--------------|
| 9 | O-ring | Viton |
| 10 | Seal | PTFE |
| 11 | V-ring | PTFE |
| 12 | Stainless steel sleeve | SS304-1.4301 |
| 13 | Spring washer | SS304-1.4301 |
| 14 | Cap | SS304-1.4301 |
| 15 | Spindle nut | A2 70 |
| 16 | Washer | SS304-1.4301 |

GEMÜ CONEXO

The interaction of valve components that are equipped with RFID chips and an associated IT infrastructure actively increase process reliability.

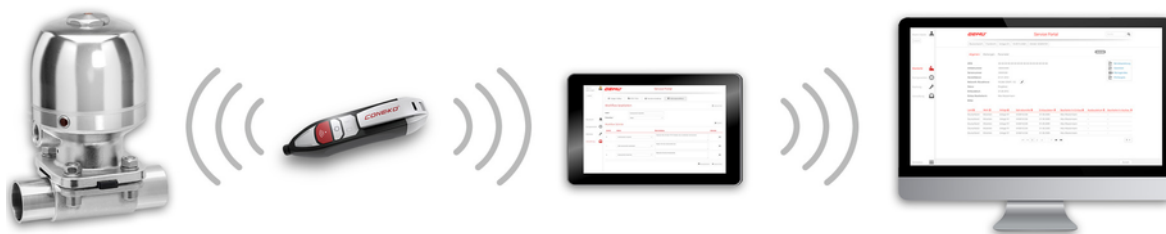

Thanks to serialization, every valve and every relevant valve component such as the body, actuator or diaphragm, and even automation components, can be clearly traced and read using the CONEXO pen RFID reader. The CONEXO app, which can be installed on mobile devices, not only facilitates and improves the "installation qualification" process, but also makes the maintenance process much more transparent and easier to document. The app actively guides the maintenance technician through the maintenance schedule and directly provides him with all the information assigned to the valve, such as test reports, testing documentation and maintenance histories. The CONEXO portal acts as a central element, helping to collect, manage and process all data.

For further information on GEMÜ CONEXO please visit:

www.gemu-group.com/conexo

Ordering

GEMÜ Conexo must be ordered separately with the ordering option "CONEXO".

Installing the RFID chip

In the corresponding design with CONEXO, this product has an RFID chip for electronic identification purposes. The position of the RFID chip can be seen below.

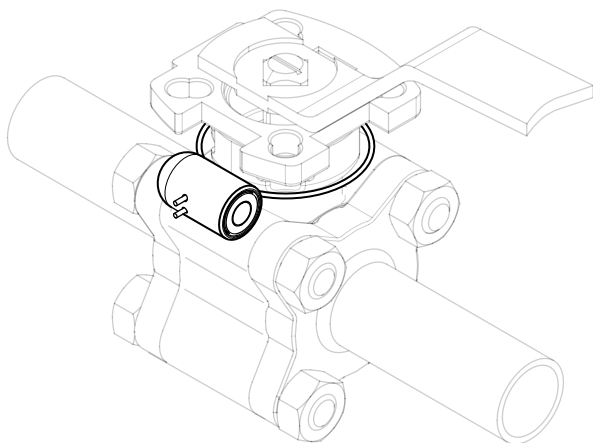

Availability

| DN | NPS | Connection type code ¹⁾ | | | | | |
|-----|------|------------------------------------|----|----|----|----|----|
| | | 17 | 37 | 59 | 60 | 80 | 93 |
| 8 | 1/4" | - | - | - | X | - | - |
| 10 | 3/8" | X | - | - | X | - | - |
| 15 | 1/2" | X | - | X | X | X | X |
| 20 | 3/4" | X | X | X | X | X | X |
| 25 | 1" | X | X | X | X | X | X |
| 32 | 1¼" | X | - | - | X | - | - |
| 40 | 1½" | X | X | X | X | X | X |
| 50 | 2" | X | X | X | X | X | X |
| 65 | 2½" | X | X | X | X | X | X |
| 80 | 3" | X | X | X | X | X | X |
| 100 | 4" | X | X | X | X | X | X |

1) **Connection type**

Code 17: Spigot EN 10357 series A/DIN 11866 series A formerly DIN 11850 series 2

Code 37: Spigot SMS 3008

Code 59: Spigot ASME BPE/DIN EN 10357 series C (from 2022 edition)/DIN 11866 series C

Code 60: Spigot ISO 1127/DIN EN 10357 series C (2014 edition)/DIN 11866 series B

Code 80: Clamp ASME BPE

Code 93: On one side, clamp ASME BPE corresponding to code 80, on the other side, butt weld spigot code 59, for pipe ASME BPE

Order data

The order data provide an overview of standard configurations.

Please check the availability before ordering. Other configurations available on request.

Products ordered with **bold marked ordering options** are so-called preferred series. Depending on the nominal size, these are available more quickly.

Order codes

| 1 Type | Code |
|---|------|
| Ball valve body, metal, three-piece body, sanitary, ISO 5211, top flange, checked delta ferrite material and media wetted surfaces according to ASME SF5, low maintenance spindle seal and blow-out proof shaft, with antistatic unit | BB04 |

| 2 DN | Code |
|--------|------|
| DN 8 | 8 |
| DN 10 | 10 |
| DN 15 | 15 |
| DN 20 | 20 |
| DN 25 | 25 |
| DN 32 | 32 |
| DN 40 | 40 |
| DN 50 | 50 |
| DN 65 | 65 |
| DN 80 | 80 |
| DN 100 | 100 |

| 3 Body/ball configuration | Code |
|---------------------------|----------|
| 2/2-way body | D |

| 4 Connection type | Code |
|--|-----------|
| Spigot EN 10357 series A/DIN 11866 series A formerly DIN 11850 series 2 | 17 |
| Spigot SMS 3008 | 37 |
| Spigot ASME BPE/DIN EN 10357 series C (from 2022 edition)/DIN 11866 series C | 59 |
| Spigot ISO 1127/DIN EN 10357 series C (2014 edition)/DIN 11866 series B | 60 |
| Clamp ASME BPE | 80 |
| On one side, clamp ASME BPE corresponding to code 80, on the other side, butt weld spigot code 59, for pipe ASME BPE | 93 |

| 5 Ball valve material | Code |
|---|------|
| 1.4435/ASTM A351, low ferrite <3% (equivalent to 316L Δ Fe<3%) (body, connection, ball), 1.4409/SS316L (spindle) | C3 |

| 6 Seal material | Code |
|---|------|
| PTFE (FDA certification) | 5T |
| PTFE (FDA certification), cavity filled | 5H |

| 7 Type of design | Code |
|------------------|------|
| Standard | |

| 7 Type of design | Code |
|---|------|
| Ra \leq 0.4 μ m (15 μ in.) for media wetted surfaces *), in accordance with DIN 11866 HE4, electropolished internal/external, *) for inner pipe diameter \leq 6 mm, in spigot Ra \leq 0.8 μ m | 1537 |
| K-NO SF5, K-NO 7056, SF5 – Ra max. 0.51 μ m (20 μ in.) electropolished internal/external, 7056 – drilled shaft, shortened hand lever | 7137 |
| K-NO SF5, K-NO 0101, SF5 – Ra max. 0.51 μ m (20 μ in.) electropolished internal/external, 0101 – media wetted area cleaned to ensure suitability for paint applications | 7140 |
| K-NO SF5, K-NO 0104, SF5 – Ra max. 0.51 μ m (20 μ in.) electropolished internal/external, 0104 – media wetted parts cleaned for high purity media and packed in plastic bag | 7141 |
| K-NO SF5, K-NO 0107, SF5 – Ra max. 0.51 μ m (20 μ in.) electropolished internal/external, 0107 – valve free of oil and grease, media wetted area cleaned | 7142 |
| Ra max. 0.38 μ m (15 μ in.) for media wetted surfaces, in accordance with ASME BPE SF4, electropolished internal/external | SF4 |
| Ra max. 0.51 μ m (20 μ in.) for media wetted surfaces, in accordance with ASME BPE SF5, electropolished internal/external | SF5 |

| 8 Special version | Code |
|-------------------|------|
| Without | |
| ATEX version | X |

| 9 CONEXO | Code |
|---|------|
| Without | |
| Integrated RFID chip for electronic identification and traceability | C |

Order example

| Ordering option | Code | Description |
|---------------------------|------|---|
| 1 Type | BB04 | Ball valve body, metal, three-piece body, sanitary, ISO 5211, top flange, checked delta ferrite material and media wetted surfaces according to ASME SF5, low maintenance spindle seal and blow-out proof shaft, with antistatic unit |
| 2 DN | 15 | DN 15 |
| 3 Body/ball configuration | D | 2/2-way body |
| 4 Connection type | 59 | Spigot ASME BPE/DIN EN 10357 series C (from 2022 edition)/DIN 11866 series C |
| 5 Ball valve material | C3 | 1.4435/ASTM A351, low ferrite <3% (equivalent to 316L Δ Fe<3%) (body, connection, ball), 1.4409/SS316L (spindle) |
| 6 Seal material | 5T | PTFE (FDA certification) |
| 7 Type of design | | Standard |
| 8 Special version | | Without |
| 9 CONEXO | | Without |

Technical data

Medium

Working medium: Corrosive, inert, gaseous and liquid media and steam which have no negative impact on the physical and chemical properties of the body and seal material.

Temperature with note

Media temperature: -10 – 220 °C
 For media temperatures > 100 °C, we recommend using a mounting kit with adapter between the ball valve and the actuator.

Ambient temperature: -20 – 60 °C

Storage temperature: -60 – 60 °C

Pressure

Operating pressure: 0 – 63 bar

Vacuum: Can be used up to a vacuum of 50 mbar (absolute)
 These values apply to room temperature and air. The values may deviate for other media and other temperatures.

Pressure/temperature diagram:

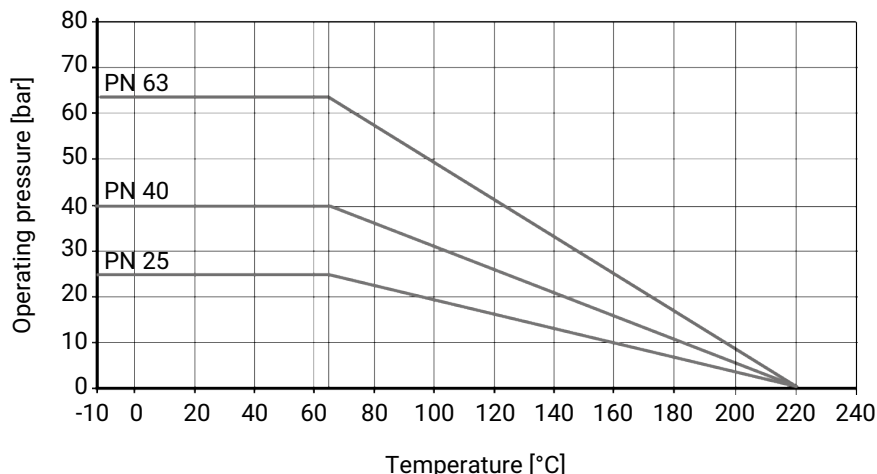

Pressure/temperature data in accordance with diagram refers to static operating conditions. Strongly fluctuating or fast-changing parameters can lead to a reduction of the service life. Special applications must be talked through with your technical contact person in advance.

Use the clamped union with the correct pressure rating for a safe and correct pipeline design. Pressure ratings of the clamp alone are generally higher, but do not take into account the fully clamped assembly with gasket

Leakage rate: Leakage rate according to ANSI FCI70 – B16.104
 Leakage rate according to EN12266, 6 bar air, leakage rate A

Technical data

Kv values:

| DN | NPS | Connection type (code) | | |
|-----|------|------------------------|----------------|--------|
| | | 17 | 37, 59, 80, 93 | 60 |
| 8 | 1/4" | 7.0 | - | 7.0 |
| 10 | 3/8" | 7.0 | - | 7.0 |
| 15 | 1/2" | 18.0 | 9.0 | 18.0 |
| 20 | 3/4" | 43.0 | 26.0 | 43.0 |
| 25 | 1" | 77.0 | 56.0 | 77.0 |
| 32 | 1¼" | 95.0 | - | 95.0 |
| 40 | 1½" | 206.0 | 172.0 | 206.0 |
| 50 | 2" | 344.0 | 327.0 | 344.0 |
| 65 | 2½" | 602.0 | 516.0 | 602.0 |
| 80 | 3" | 844.0 | 817.0 | 844.0 |
| 100 | 4" | 1462.0 | 1376.0 | 1462.0 |

Cv values in m³/h

Pressure rating:

| DN | Connection type (code) | | | |
|-----|------------------------|--------|------|--------|
| | 17 | 37, 59 | 60 | 80, 93 |
| 8 | - | - | PN63 | - |
| 10 | PN63 | - | PN63 | - |
| 15 | PN63 | PN63 | PN63 | PN25 |
| 20 | PN63 | PN63 | PN63 | PN25 |
| 25 | PN63 | PN63 | PN63 | PN25 |
| 32 | PN63 | - | PN63 | - |
| 40 | PN63 | PN63 | PN63 | PN25 |
| 50 | PN63 | PN63 | PN63 | PN16 |
| 65 | PN40 | PN40 | PN40 | PN16 |
| 80 | PN40 | PN40 | PN40 | PN10 |
| 100 | PN25 | PN25 | PN25 | PN10 |





For clamp connections, the permissible pressures are designed for a temperature of -10 to 140 °C when using suitable clamps and sealing materials.

Product conformities

Pressure Equipment Directive: 2014/68/EU

Food: FDA
Regulation (EC) No. 1935/2004
Regulation (EC) No. 10/2011

Explosion protection: ATEX (2014/34/EU), order code Special version X

ATEX marking:
Up to DN 65
Gas:  II 2G Ex h IIC T6 ... T2 Gb X
Dust:  II -/2D Ex h -/IIIC T180 °C -/Db X
DN 80 and 100
Gas:  II 2G Ex h IIB T6 ... T2 Gb X
Dust:  II -/2D Ex h -/IIIC T180 °C -/Db X

Mechanical data

Torques:

| DN | NPS | Seal material (code) | |
|-----|------|----------------------|-----|
| | | 5T | 5H |
| 8 | 1/4" | 4 | 4 |
| 10 | 3/8" | 4 | 4 |
| 15 | 1/2" | 8 | 12 |
| 20 | 3/4" | 8 | 12 |
| 25 | 1" | 13 | 19 |
| 32 | 1¼" | 16 | 22 |
| 40 | 1½" | 32 | 47 |
| 50 | 2" | 34 | 51 |
| 65 | 2½" | 91 | 105 |
| 80 | 3" | 104 | 120 |
| 100 | 4" | 140 | 209 |

Free of oil and grease incl. 25% safety
Torques in Nm

Weight:

| DN | NPS | Connection type (code) | | | |
|-----|------|------------------------|--------|------|--------|
| | | 17 | 37, 59 | 60 | 80, 93 |
| 8 | 1/4" | - | - | 0.5 | - |
| 10 | 3/8" | - | - | 0.5 | - |
| 15 | 1/2" | 0.8 | 0.5 | 0.5 | 0.5 |
| 20 | 3/4" | 0.8 | 0.5 | 0.8 | 0.5 |
| 25 | 1" | 1.1 | 1.0 | 1.1 | 1.1 |
| 32 | 1¼" | 1.6 | - | 1.6 | - |
| 40 | 1½" | 2.7 | 2.1 | 2.7 | 2.2 |
| 50 | 2" | 4.2 | 3.5 | 4.2 | 3.5 |
| 65 | 2½" | 8.2 | 7.0 | 8.2 | 7.1 |
| 80 | 3" | 11.6 | 11.0 | 11.6 | 11.8 |
| 100 | 4" | 24.0 | 20.0 | 24.0 | 20.5 |

Weights in kg

Dimensions

Actuator flange

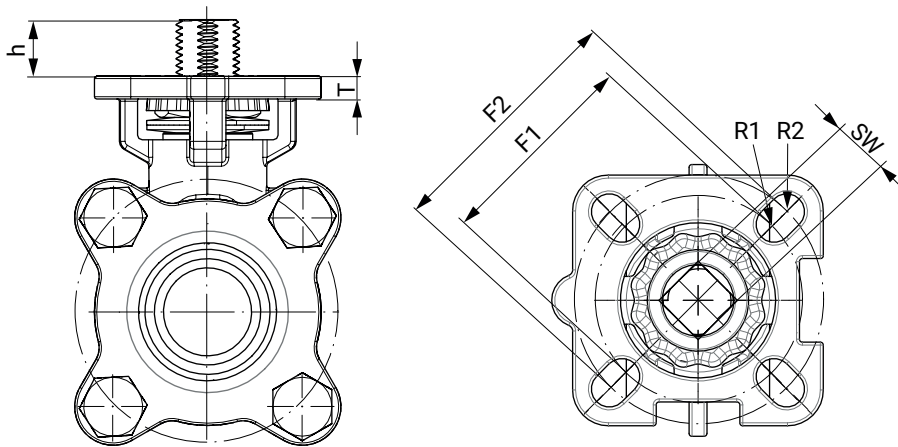

| DN | G | F1 | ISO 5211 (F1) | R1 | F2 | ISO 5211 (F2) | R2 | SW | h | T |
|-----|--------|-------|------------------|-----|-------|------------------|-----|------|------|------|
| 8 | 1/4" | 36.0 | F03 | 3.0 | 42.0 | F04 | 3.0 | 9.0 | 9.0 | 5.0 |
| 10 | 3/8" | 36.0 | F03 | 3.0 | 42.0 | F04 | 3.0 | 9.0 | 9.0 | 5.0 |
| 15 | 1/2" | 36.0 | F03 | 3.0 | 42.0 | F04 | 3.0 | 9.0 | 9.0 | 5.0 |
| 20 | 3/4" | 36.0 | F03 | 3.0 | 42.0 | F04 | 3.0 | 9.0 | 7.5 | 5.0 |
| 25 | 1" | 42.0 | F04 | 3.0 | 50.0 | F05 | 3.5 | 11.0 | 13.0 | 7.0 |
| 32 | 1 1/4" | 42.0 | F04 | 3.0 | 50.0 | F05 | 3.5 | 11.0 | 13.0 | 7.0 |
| 40 | 1 1/2" | 50.0 | F05 | 3.5 | 70.0 | F07 | 4.5 | 14.0 | 15.0 | 9.0 |
| 50 | 2" | 50.0 | F05 | 3.5 | 70.0 | F07 | 4.5 | 14.0 | 16.0 | 9.0 |
| 65 | 2 1/2" | 50.0 | F07 | 3.5 | 70.0 | F10 | 4.5 | 17.0 | 18.0 | 10.5 |
| 80 | 3" | 70.0 | F07 | 4.5 | 102.0 | F10 | 5.5 | 17.0 | 18.0 | 10.5 |
| 100 | 4" | 102.0 | F10 | 4.5 | 125.0 | F12 | 5.5 | 22.0 | 26.0 | 10.5 |

Dimensions in mm

Body dimensions

Spigot DIN EN 10357 (connection code 17)

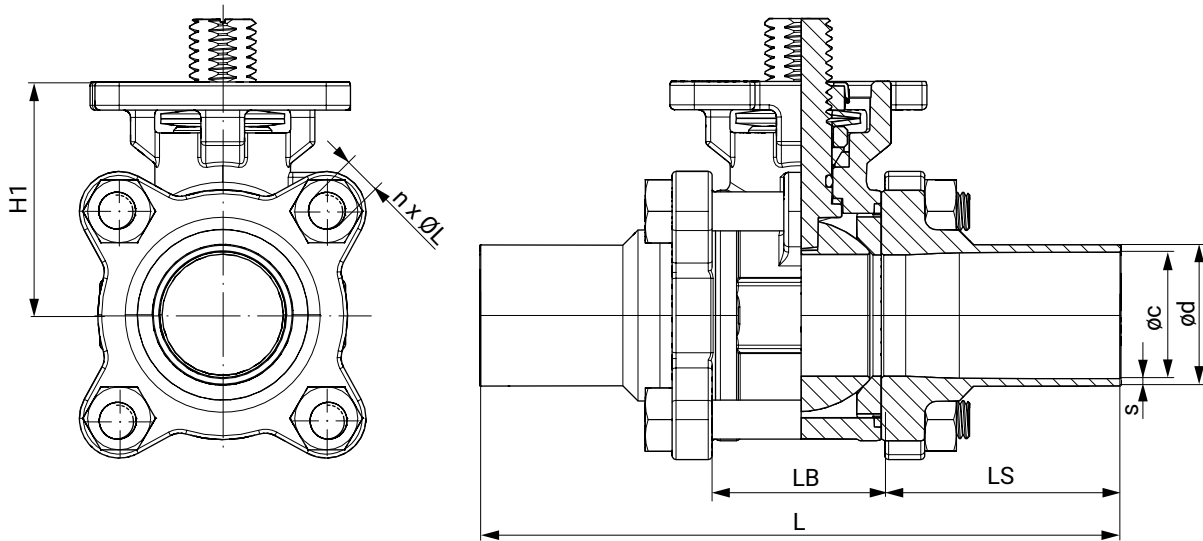

| DN | øc | ød | L | LB | LS | H1 | n x ØL | s |
|-----|-------|-------|-------|-------|------|-------|---------|-----|
| 10 | 10.0 | 13.0 | 120.1 | 24.3 | 47.9 | 37.0 | 4 x M6 | 1.5 |
| 15 | 16.0 | 19.0 | 140.1 | 24.3 | 57.9 | 37.0 | 4 x M6 | 1.5 |
| 20 | 20.0 | 23.0 | 140.0 | 31.2 | 54.4 | 40.0 | 4 x M8 | 1.5 |
| 25 | 26.0 | 29.0 | 152.0 | 34.0 | 59.0 | 48.0 | 4 x M8 | 1.5 |
| 32 | 32.0 | 35.0 | 165.0 | 44.0 | 60.5 | 53.0 | 4 x M10 | 1.5 |
| 40 | 38.0 | 41.0 | 190.0 | 55.0 | 67.5 | 63.0 | 4 x M12 | 1.5 |
| 50 | 50.0 | 53.0 | 203.0 | 68.9 | 67.0 | 72.0 | 4 x M14 | 1.5 |
| 65 | 66.0 | 70.0 | 254.0 | 82.0 | 86.0 | 92.0 | 4 x M14 | 2.0 |
| 80 | 81.0 | 85.0 | 280.0 | 96.0 | 92.0 | 102.0 | 4 x M16 | 2.0 |
| 100 | 100.0 | 104.0 | 308.0 | 122.0 | 93.0 | 132.0 | 6 x M20 | 2.0 |

Dimensions in mm
n = number of bolts

Spigot SMS 3008 (connection code 37)

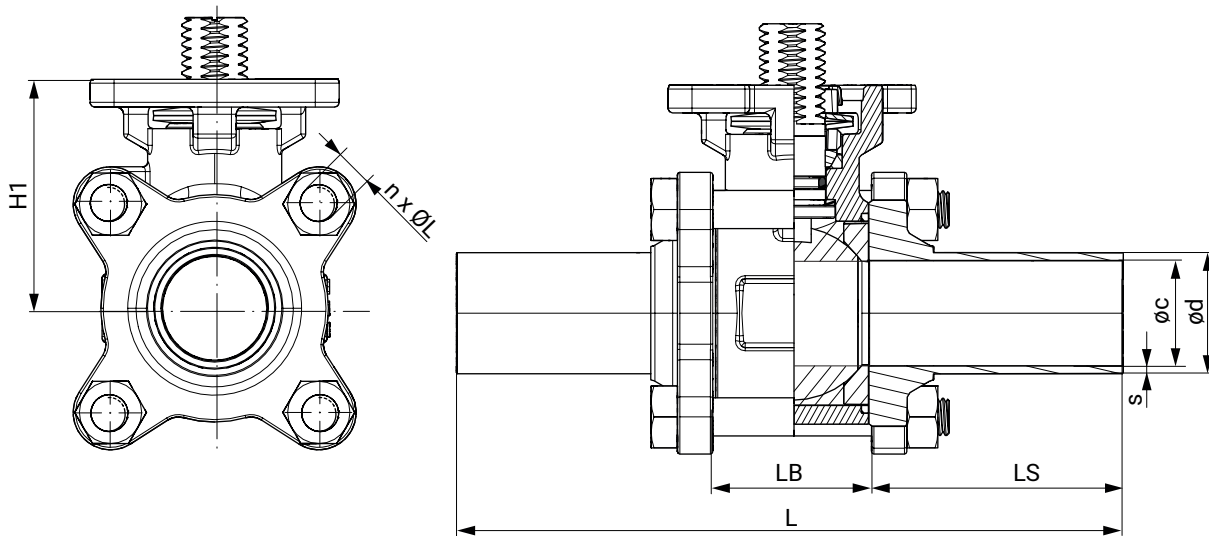

| DN | Øc | Ød | s | t | L | LB | LS | H1 | n x ØL |
|-----|------|-------|-----|------|-------|-------|------|-------|---------|
| 20 | 16.0 | 18.0 | 1.0 | 6.1 | 142.2 | 28.0 | 58.6 | 38.0 | 4 x M6 |
| 25 | 22.6 | 25.0 | 1.2 | 7.4 | 162.3 | 32.1 | 65.1 | 48.0 | 4 x M8 |
| 40 | 35.6 | 38.0 | 1.2 | 8.3 | 182.2 | 46.0 | 68.1 | 60.0 | 4 x M12 |
| 50 | 48.6 | 51.0 | 1.2 | 10.2 | 193.0 | 59.6 | 66.7 | 69.0 | 4 x M14 |
| 65 | 60.3 | 63.5 | 1.6 | 12.5 | 254.1 | 77.1 | 88.5 | 89.0 | 4 x M14 |
| 80 | 72.9 | 76.1 | 1.6 | 14.0 | 276.9 | 91.7 | 92.6 | 98.0 | 4 x M16 |
| 100 | 97.6 | 101.6 | 2.0 | 14.5 | 304.9 | 118.3 | 93.3 | 130.0 | 6 x M16 |

Dimensions in mm
n = number of bolts

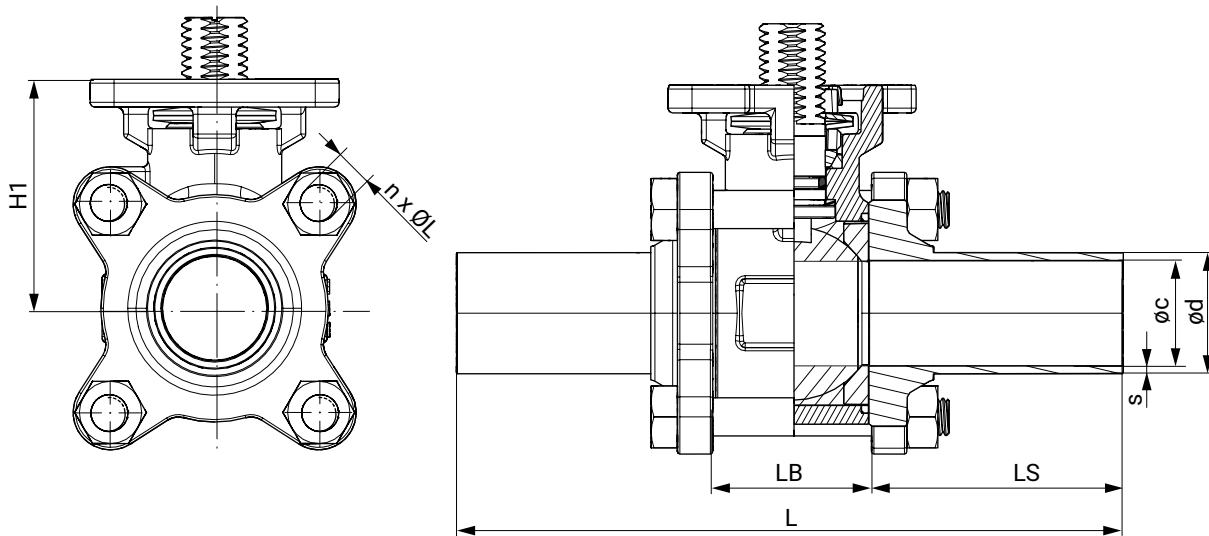
Spigot ASME BPE (connection code 59)

| DN | øc | ød | s | L | LB | LS | H1 | n x ØL |
|-----|-------|--------|------|--------|--------|-------|--------|---------|
| 15 | 9.40 | 12.70 | 1.65 | 124.40 | 25.00 | 49.70 | 38.00 | 4 x M6 |
| 20 | 15.70 | 19.05 | 1.65 | 142.20 | 28.00 | 58.60 | 38.00 | 4 x M6 |
| 25 | 22.10 | 25.40 | 1.65 | 162.30 | 32.10 | 65.10 | 48.00 | 4 x M8 |
| 40 | 34.80 | 38.10 | 1.65 | 182.20 | 46.00 | 68.10 | 60.00 | 4 x M12 |
| 50 | 47.50 | 50.80 | 1.65 | 193.00 | 59.60 | 66.70 | 69.00 | 4 x M14 |
| 65 | 60.20 | 63.50 | 1.65 | 254.10 | 77.10 | 88.50 | 89.00 | 4 x M14 |
| 80 | 72.90 | 76.20 | 1.65 | 276.90 | 91.70 | 92.60 | 98.00 | 4 x M16 |
| 100 | 97.40 | 101.60 | 2.10 | 304.90 | 118.30 | 93.30 | 130.00 | 6 x M16 |

Dimensions in mm
n = number of bolts

Spigot ISO 1127 / EN 10357 (connection code 60)

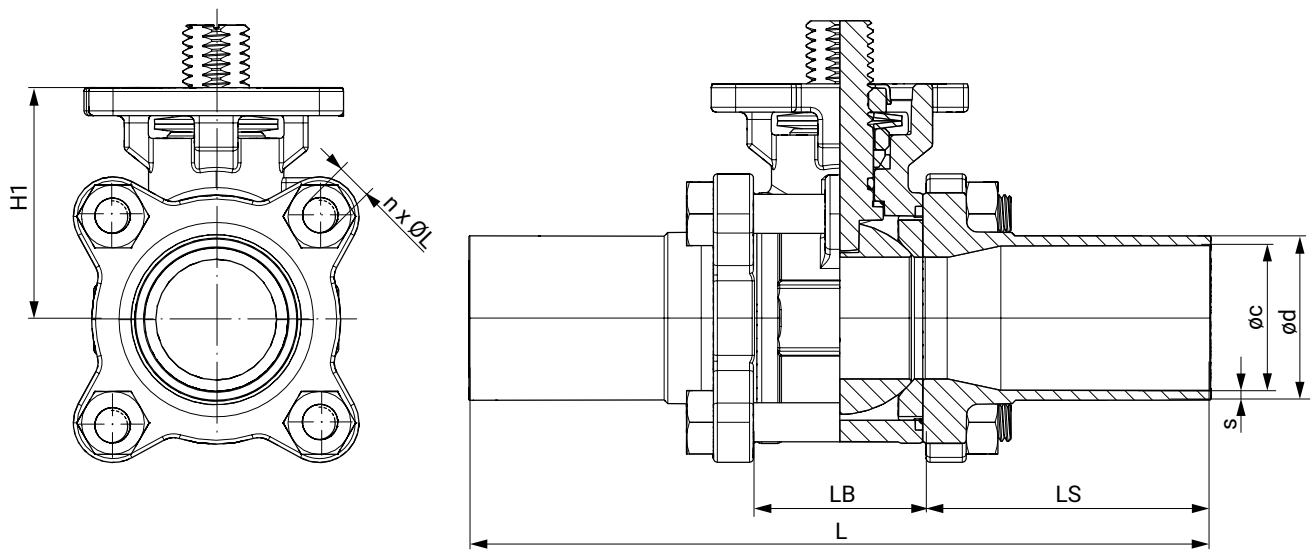

| DN | øc | ød | s | L | LB | LS | H1 | n x ØL |
|------------|-------|-------|-----|-------|-------|------|-------|---------|
| 8 | 10.3 | 13.5 | 1.6 | 120.1 | 24.3 | 47.9 | 37.0 | 4 x M6 |
| 10 | 14.0 | 17.2 | 1.6 | 120.1 | 24.3 | 47.9 | 37.0 | 4 x M6 |
| 15 | 18.1 | 21.3 | 1.6 | 140.1 | 24.3 | 57.9 | 37.0 | 4 x M6 |
| 20 | 23.7 | 26.9 | 1.6 | 140.0 | 31.2 | 54.4 | 40.0 | 4 x M8 |
| 25 | 29.7 | 33.7 | 2.0 | 152.0 | 34.0 | 59.0 | 48.0 | 4 x M8 |
| 32 | 38.4 | 42.4 | 2.0 | 165.0 | 44.0 | 60.5 | 53.0 | 4 x M10 |
| 40 | 44.3 | 48.3 | 2.0 | 190.0 | 55.0 | 67.5 | 63.0 | 4 x M12 |
| 50 | 56.3 | 60.3 | 2.0 | 203.0 | 68.9 | 67.0 | 72.0 | 4 x M14 |
| 65 | 72.1 | 76.1 | 2.0 | 254.0 | 82.0 | 86.0 | 92.0 | 4 x M14 |
| 80 | 84.3 | 88.9 | 2.3 | 280.0 | 96.0 | 92.0 | 102.0 | 4 x M16 |
| 100 | 109.7 | 114.3 | 2.3 | 308.0 | 122.0 | 93.0 | 132.0 | 6 x M20 |

Dimensions in mm
n = number of bolts

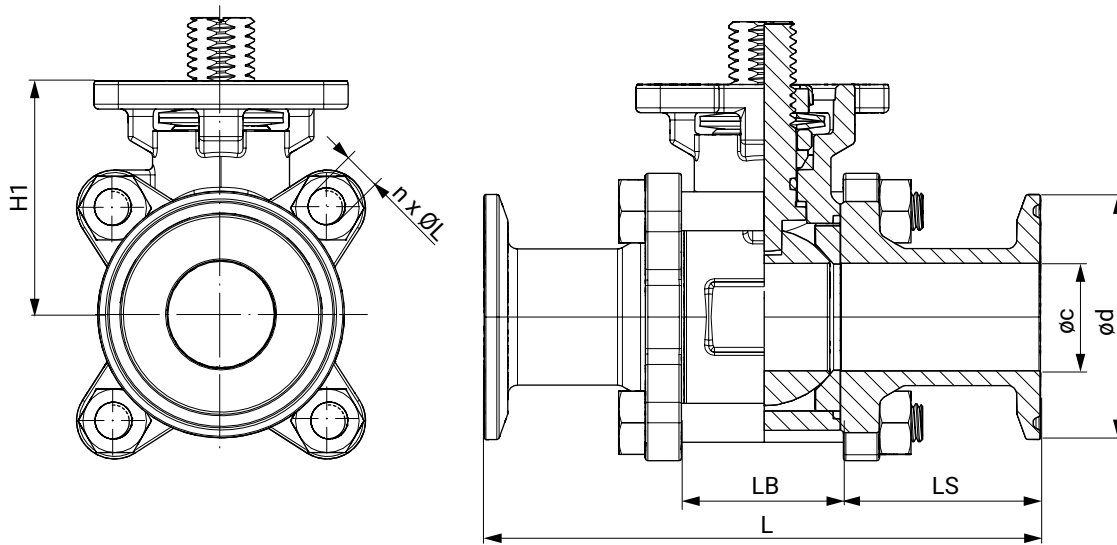
Clamp ASME BPE (connection code 80)

| DN | Øc | Ød | s | L | LB | LS | H1 | n x ØL |
|------------|------|-------|------|-------|-------|------|-------|---------|
| 15 | 9.4 | 25.0 | 1.65 | 88.8 | 25.0 | 31.9 | 38.0 | 4 x M6 |
| 20 | 15.8 | 25.0 | 1.65 | 101.6 | 25.0 | 38.3 | 38.0 | 4 x M6 |
| 25 | 22.1 | 50.4 | 1.65 | 114.3 | 32.1 | 41.1 | 48.0 | 4 x M8 |
| 40 | 34.8 | 50.4 | 1.65 | 139.8 | 46.0 | 46.9 | 60.0 | 4 x M12 |
| 50 | 47.5 | 63.9 | 1.65 | 158.8 | 59.6 | 49.6 | 69.0 | 4 x M14 |
| 65 | 60.2 | 77.4 | 1.65 | 171.5 | 77.1 | 47.2 | 89.0 | 4 x M14 |
| 80 | 72.9 | 90.9 | 1.65 | 196.3 | 91.7 | 52.3 | 98.0 | 4 x M16 |
| 100 | 97.4 | 118.9 | 2.1 | 241.3 | 118.3 | 61.5 | 130.0 | 6 x M16 |

Dimensions in mm
n = number of bolts

Mixed ends ASME BPE (connection code 93)

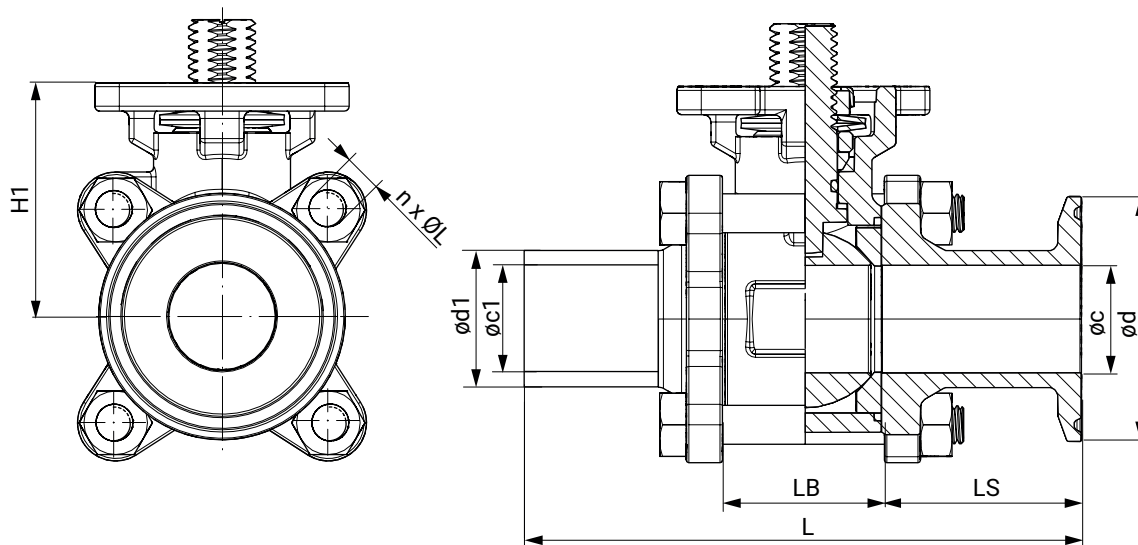

| DN | Øc | Ød | Øc1 | Ød1 | s | t | L | LB | LS | H1 | n x ØL |
|-----|------|-------|------|-------|------|------|-------|-------|------|-------|---------|
| 15 | 9.4 | 25.0 | 9.4 | 12.7 | 1.65 | 6.1 | 106.6 | 25.0 | 49.7 | 38.0 | 4 x M6 |
| 20 | 15.8 | 25.0 | 15.8 | 19.0 | 1.65 | 6.1 | 121.9 | 28.0 | 58.6 | 38.0 | 4 x M6 |
| 25 | 22.1 | 50.4 | 22.1 | 25.4 | 1.65 | 7.4 | 138.3 | 32.1 | 65.1 | 48.0 | 4 x M8 |
| 40 | 34.8 | 50.4 | 34.8 | 38.1 | 1.65 | 8.3 | 161.0 | 46.0 | 68.1 | 60.0 | 4 x M12 |
| 50 | 47.5 | 63.9 | 47.5 | 50.8 | 1.65 | 10.2 | 175.9 | 59.6 | 66.7 | 69.0 | 4 x M14 |
| 65 | 60.2 | 77.4 | 60.2 | 63.5 | 1.65 | 12.5 | 212.8 | 77.1 | 88.5 | 89.0 | 4 x M14 |
| 80 | 72.9 | 90.9 | 72.9 | 76.2 | 1.65 | 14.0 | 236.6 | 91.7 | 92.6 | 98.0 | 4 x M16 |
| 100 | 97.4 | 118.9 | 97.4 | 101.6 | 2.10 | 14.5 | 273.1 | 118.3 | 93.3 | 130.0 | 6 x M16 |

Dimensions in mm
n = number of bolts

Add-on components



GEMÜ DR

Pneumatic quarter turn actuator

GEMÜ DR is a pneumatic double acting quarter turn actuator. It works according to the double piston rack and pinion principle and is suitable for mounting to butterfly valves or ball valves.



GEMÜ SC

Pneumatic quarter turn actuator

GEMÜ SC is a pneumatic single acting quarter turn actuator. It works according to the double piston rack and pinion principle and is suitable for mounting to butterfly valves or ball valves.



GEMÜ ADA

Pneumatic quarter turn actuator

GEMÜ ADA is a pneumatic double acting quarter turn actuator. It works according to the double piston rack and pinion principle and is suitable for mounting to butterfly valves or ball valves.



GEMÜ ASR

Pneumatic quarter turn actuator

GEMÜ ASR is a pneumatic single acting quarter turn actuator. It works according to the double piston rack and pinion principle and is suitable for mounting to butterfly valves or ball valves.



GEMÜ 9428

Motorized quarter turn actuator

The product is a motorized quarter turn actuator. The actuator is designed for DC or AC operating voltages. A manual override and an optical position indicator are integrated as standard. The torque in the end positions is increased. This enables a closing curve matched to the valves.



GEMÜ J4C

Motorized quarter turn actuator

The J4C actuator is a motorized quarter turn actuator. The motor is designed for DC and AC operating voltages. A manual override and an optical position indicator are integrated as standard. The end positions are potential-free and adjustable.

GEMÜ AB24



Hand lever or gearbox with handwheel

Hand lever with standard flange according to EN ISO 5211 for the manual operation of quarter turn valves.

Accessories

GEMÜ RC0

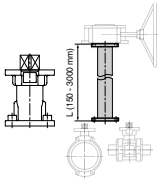

Shaft extension

The RC0 shaft extension for quarter turn valves is a distance piece between manually, pneumatically or electrically operated valves. This means that valves can be protected from flooding or better access for operation of the valve can be ensured (also for manual override).

| Nominal size | GEMÜ RC0 shaft extension | | GEMÜ AB22 and AB24 hand lever | |
|--------------|--------------------------|-----------------------------|-------------------------------|----------------|
| | Item no. | Designation | Item no. | Designation |
| DN 8–20 | 88742081 | RC0VAF04 D09KF04 D09 60 M12 | 88658096 | AB22 20D OSET |
| DN 25–32 | 88742082 | RC0VAF05 D11KF05 D11 65 M14 | 88658097 | AB22 32D OSET |
| DN 40–50 | 88742083 | RC0VAF07 D14KF07 D14 80 M18 | 88658099 | AB22 50D OSET |
| DN 65 | 88742085 | RC0VAF07 D17KF07 D17100 M22 | 88660113 | AB26 65D OSET |
| DN 80 | 88742085 | RC0VAF07 D17KF07 D17100 M22 | 88660114 | AB26 80D OSET |
| DN 100 | 88781980 | RC0VAF12 D22KF12 D22 75 M28 | 88660420 | AB24 100D OSET |

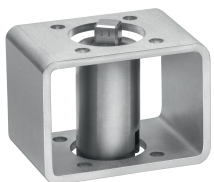

GEMÜ MSC

Mounting kit

The MSC mounting kit is an interface, for the same and different ends, to join flange designs according to ISO 5211. This mounting kit ensures thermal separation of actuator and valve body. It can also be used as height compensation for insulated pipelines. The mounting kit is available in steel, electrogalvanized and stainless steel in an open or closed design.

GEMÜ ADH

Mounting sleeve

The mounting sleeve accessories are available in the square and star geometry designs. These are used for the shaft and hub support for quarter turn actuators. Both sleeves have an internal square drive (please observe stated measurement dimensions here). The sleeve material is sintered metal and they are chemically nickel plated with a surface of 25 µm.

Certificates

| Certificate | Standard | Item number |
|-----------------------------------|-----------------------|-------------|
| 2.2 Ferrite content measurement | | 88081058 |
| 2.2 Surface roughness measurement | EN10204 - EN ISO 4288 | 88079146 |

| Certificate | Standard | Item number |
|-----------------------------------|----------|-------------|
| 3.1 Surface roughness measurement | | 88094384 |
| 3.1 Material | EN 10204 | 88333336 |



GEMÜ Gebr. Müller Apparatebau GmbH & Co. KG
Fritz-Müller-Straße 6-8, 74653 Ingelfingen-Criesbach, Germany
Phone +49 (0) 7940 1230 · info@gemue.de
www.gemu-group.com