

GEMÜ BB04

Ball valve with bare shaft

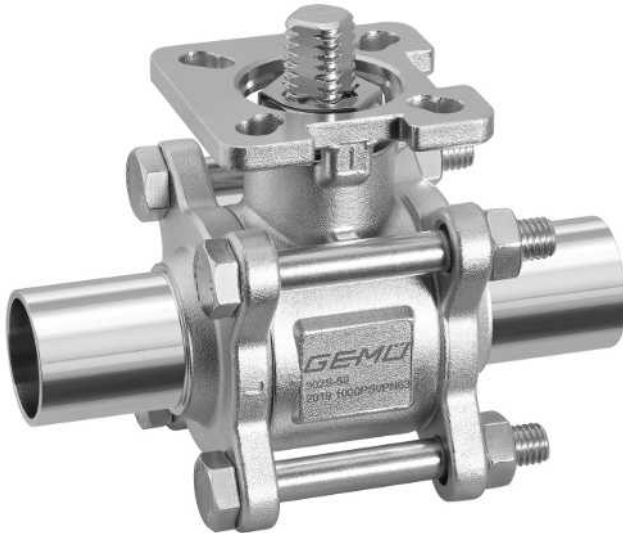

Features

- Checked delta ferrite material < 3% (1.4435)
- Material certificates for media wetted components
- Media wetted surfaces according to ASME SF5 (Ra 0.51 µm)
- Butt weld spigots in extended orbital welding design
- Optionally available with cavity-filled seat
- Suitable for vacuum applications
- Option: ATEX version
- Ball valve body, assembled free of oil/grease

Description

The three-piece 2/2-way GEMÜ BB04 metal ball valve with a bare shaft and an actuator flange in accordance with DIN ISO 5211 for simple mounting of various actuator types is particularly suited to applications in the supply sector for the pharmaceutical, foodstuffs processing and biotechnology (such as water treatment and steam generation) industries thanks to the 1.4435 stainless steel alloy material composition used (compliant with 316L) with a low delta ferrite proportion of < 3%. Only those plastics which are compliant with FDA, USP Class VI and Regulation (EU) No.10/2011 are used for the seals.

Technical specifications

- **Media temperature:** 14 to 428 °F
- **Ambient temperature:** -4 to 140 °F
- **Operating pressure:** 0 to 914 psi
- **Body configurations:** 2/2-way body
- **Connection type:** Clamp | Spigot
- **Connection standards:** ASME | DIN | ISO | SMS
- **Body materials:** 1.4435 (316L), investment casting material
- **Seal materials:** PTFE
- **Conformities:** ATEX | EAC | FDA | Reg. (EU) No. 10/2011 | Regulation (EC) No. 1935/2004 | TA Luft (German Clean Air Act) | USP

Technical data depends on the respective configuration



further information
webcode: GW-BB04



Product line

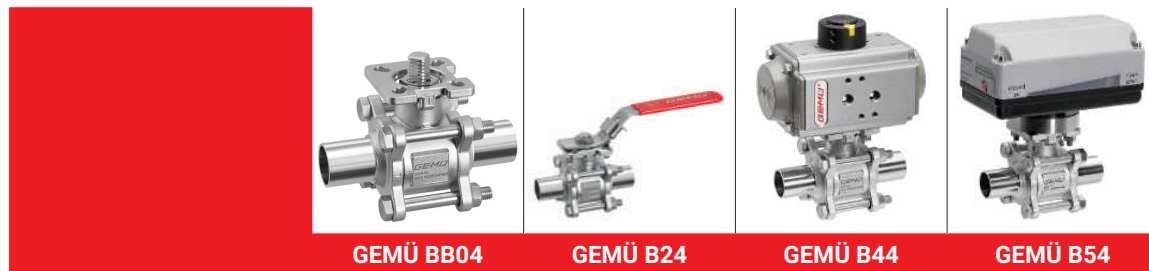

	GEMÜ BB04	GEMÜ B24	GEMÜ B44	GEMÜ B54
Operation				
With bare shaft	●	-	-	-
Manual	-	●	-	-
pneumatic	-	-	●	-
Motorized	-	-	-	●
Nominal sizes	1/4" (DN 8) to 4" (DN 100)	1/4" (DN 8) to 4" (DN 100)	1/4" (DN 8) to 4" (DN 100)	1/4" (DN 8) to 4" (DN 100)
Media temperature	14 to 428 °F	14 to 428 °F	14 to 428 °F	14 to 428 °F
Operating pressure	0 to 914 psi	0 to 914 psi	0 to 914 psi	0 to 914 psi
Connection types				
Clamp	●	●	●	●
Spigot	●	●	●	●

Product description

Construction

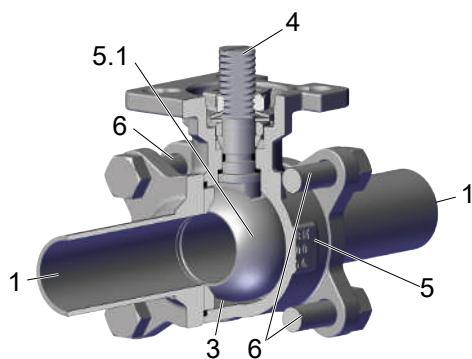

Item	Name	Materials
5	Ball valve body	ASTM A351/1.4435 (316L)
1	Pipe connections	ASTM A351/1.4435 (316L)
5.1	Ball	ASTM A351/1.4435 (316L)
4	Ball valve shaft	1.4409 (SS316L)
6	Bolt	A2 70
3	Seals	PTFE

Cavity-filled PTFE seal (Code 5H)



- The cavity-filled seal, which is made of PTFE, is specially designed to reduce excess volumes in the ball cavity.
- Media that remains in the valve's dead spaces is unwanted during food production, for example, and may decontaminate this.
- These deposits accumulate and contaminate the entire process. Thanks to this special seal variant, the volume in the ball cavity is reduced to a minimum.

Application

- Water treatment
- Steam processing
- CIP/SIP
- Waste water treatment
- Storage and distribution
- Drying

The spindle seal system

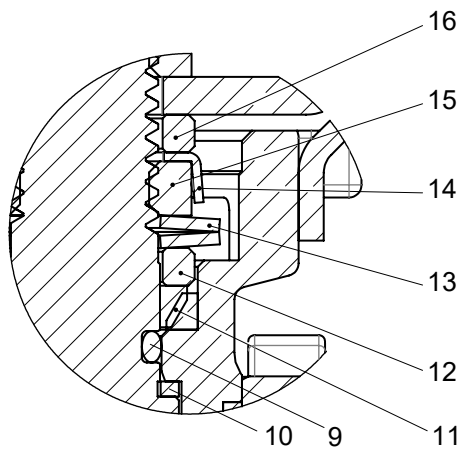

Item	Name	Material
9	O-ring	Viton
10	Seal	PTFE
11	V-ring	PTFE
12	Stainless steel sleeve	SS304-1.4301
13	Spring washer	SS304-1.4301
14	Cap	SS304-1.4301
15	Spindle nut	A2 70
16	Washer	SS304-1.4301

GEMÜ CONEXO

The interaction of valve components that are equipped with RFID chips and an associated IT infrastructure actively increase process reliability.



Thanks to serialization, every valve and every relevant valve component such as the body, actuator or diaphragm, and even automation components, can be clearly traced and read using the CONEXO pen RFID reader. The CONEXO app, which can be installed on mobile devices, not only facilitates and improves the "installation qualification" process, but also makes the maintenance process much more transparent and easier to document. The app actively guides the maintenance technician through the maintenance schedule and directly provides him with all the information assigned to the valve, such as test reports, testing documentation and maintenance histories. The CONEXO portal acts as a central element, helping to collect, manage and process all data.

For further information on GEMÜ CONEXO please visit:

www.gemu-group.com/conexo

Ordering

GEMÜ Conexo must be ordered separately with the ordering option "CONEXO".

Installing the RFID chip

In the corresponding design with CONEXO, this product has an RFID chip for electronic identification purposes. The position of the RFID chip can be seen below.

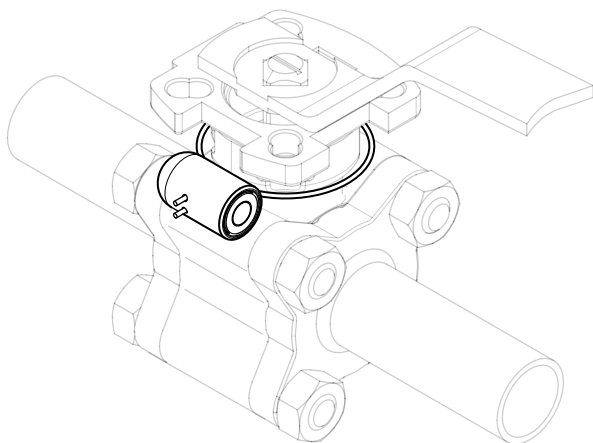

Availability

DN	NPS	Connection type code ¹⁾					
		17	37	59	60	80	93
8	1/4"	-	-	-	X	-	-
10	3/8"	X	-	-	X	-	-
15	1/2"	X	-	X	X	X	X
20	3/4"	X	X	X	X	X	X
25	1"	X	X	X	X	X	X
32	1¼"	X	-	-	X	-	-
40	1½"	X	X	X	X	X	X
50	2"	X	X	X	X	X	X
65	2½"	X	X	X	X	X	X
80	3"	X	X	X	X	X	X
100	4"	X	X	X	X	X	X

1) **Connection type**

Code 17: Spigot EN 10357 series A/DIN 11866 series A formerly DIN 11850 series 2

Code 37: Spigot SMS 3008

Code 59: Spigot ASME BPE/DIN EN 10357 series C (from 2022 edition)/DIN 11866 series C

Code 60: Spigot ISO 1127/DIN EN 10357 series C (2014 edition)/DIN 11866 series B

Code 80: Clamp ASME BPE

Code 93: On one side, clamp ASME BPE corresponding to code 80, on the other side, butt weld spigot code 59, for pipe ASME BPE

Order data

The order data provide an overview of standard configurations.

Please check the availability before ordering. Other configurations available on request.

Products ordered with **bold marked ordering options** are so-called preferred series. Depending on the nominal size, these are available more quickly.

Order codes

1 Type	Code
Ball valve body, metal, three-piece body, sanitary, ISO 5211, top flange, checked delta ferrite material and media wetted surfaces according to ASME SF5, low maintenance spindle seal and blow-out proof shaft, with antistatic unit	BB04

2 DN	Code
DN 8	8
DN 10	10
DN 15	15
DN 20	20
DN 25	25
DN 32	32
DN 40	40
DN 50	50
DN 65	65
DN 80	80
DN 100	100

3 Body/ball configuration	Code
2/2-way body	D

4 Connection type	Code
Spigot EN 10357 series A/DIN 11866 series A formerly DIN 11850 series 2	17
Spigot SMS 3008	37
Spigot ASME BPE/DIN EN 10357 series C (from 2022 edition)/DIN 11866 series C	59
Spigot ISO 1127/DIN EN 10357 series C (2014 edition)/DIN 11866 series B	60
Clamp ASME BPE	80
On one side, clamp ASME BPE corresponding to code 80, on the other side, butt weld spigot code 59, for pipe ASME BPE	93

5 Ball valve material	Code
1.4435/ASTM A351, low ferrite <3% (equivalent to 316L Δ Fe<3%) (body, connection, ball), 1.4409/SS316L (spindle)	C3

6 Seal material	Code
PTFE (FDA certification)	5T
PTFE (FDA certification), cavity filled	5H

7 Type of design	Code
Standard	

7 Type of design	Code
Ra \leq 0.4 μ m (15 μ in.) for media wetted surfaces *), in accordance with DIN 11866 HE4, electropolished internal/external, *) for inner pipe diameter \leq 6 mm, in spigot Ra \leq 0.8 μ m	1537
K-NO SF5, K-NO 7056, SF5 – Ra max. 0.51 μ m (20 μ in.) electropolished internal/external, 7056 – drilled shaft, shortened hand lever	7137
K-NO SF5, K-NO 0101, SF5 – Ra max. 0.51 μ m (20 μ in.) electropolished internal/external, 0101 – media wetted area cleaned to ensure suitability for paint applications	7140
K-NO SF5, K-NO 0104, SF5 – Ra max. 0.51 μ m (20 μ in.) electropolished internal/external, 0104 – media wetted parts cleaned for high purity media and packed in plastic bag	7141
K-NO SF5, K-NO 0107, SF5 – Ra max. 0.51 μ m (20 μ in.) electropolished internal/external, 0107 – valve free of oil and grease, media wetted area cleaned	7142
Ra max. 0.38 μ m (15 μ in.) for media wetted surfaces, in accordance with ASME BPE SF4, electropolished internal/external	SF4
Ra max. 0.51 μ m (20 μ in.) for media wetted surfaces, in accordance with ASME BPE SF5, electropolished internal/external	SF5

8 Special version	Code
Without	
ATEX version	X

9 CONEXO	Code
Without	
Integrated RFID chip for electronic identification and traceability	C

Order example

Order option	Code	Description
1 Type	BB04	Ball valve body, metal, three-piece body, sanitary, ISO 5211, top flange, checked delta ferrite material and media wetted surfaces according to ASME SF5, low maintenance spindle seal and blow-out proof shaft, with antistatic unit
2 DN	15	DN 15
3 Body/ball configuration	D	2/2-way body
4 Connection type	59	Spigot ASME BPE/DIN EN 10357 series C (from 2022 edition)/DIN 11866 series C
5 Ball valve material	C3	1.4435/ASTM A351, low ferrite <3% (equivalent to 316L Δ Fe<3%) (body, connection, ball), 1.4409/SS316L (spindle)
6 Seal material	5T	PTFE (FDA certification)
7 Type of design		Standard
8 Special version		Without
9 CONEXO		Without

Technical data

Medium

Working medium: Corrosive, inert, gaseous and liquid media and steam which have no negative impact on the physical and chemical properties of the body and seal material.

Temperature with note

Media temperature: 14 – 428 °F
 For media temperatures > 212 °F, we recommend using a mounting kit with adapter between the ball valve and the actuator.

Ambient temperature: -4 – 140 °F

Storage temperature: -76 – 140 °F

Pressure

Operating pressure: 0 – 914 psi

Vacuum: Can be used up to a vacuum of 1.5 inhg (absolute)
 These values apply to room temperature and air. The values may deviate for other media and other temperatures.

Pressure/temperature diagram:

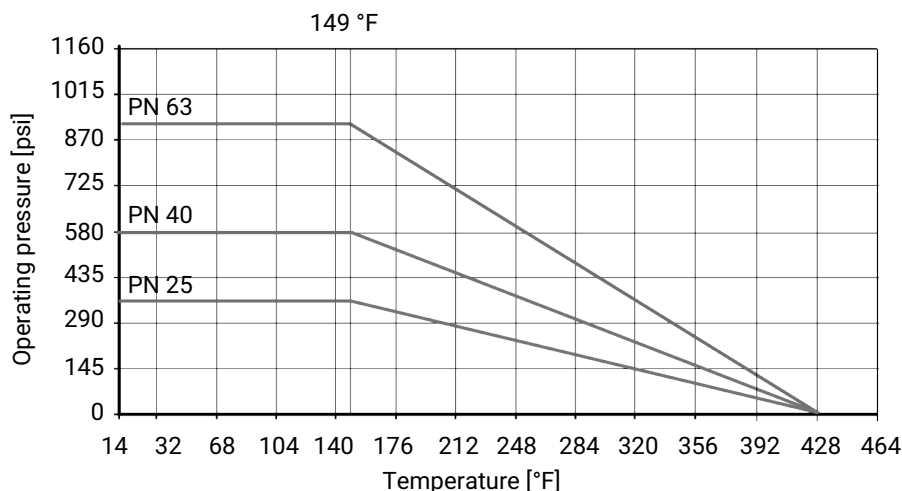

Pressure/temperature data in accordance with diagram refers to static operating conditions. Strongly fluctuating or fast-changing parameters can lead to a reduction of the service life. Special applications must be talked through with your technical contact person in advance.

Use the clamped union with the correct pressure rating for a safe and correct pipeline design. Pressure ratings of the clamp alone are generally higher, but do not take into account the fully clamped assembly with gasket

Leakage rate: Leakage rate according to ANSI FCI70 – B16.104
 Leakage rate according to EN 12266, 87 psi air, leakage rate A

Technical data

Leakage rate:

DN	NPS	Connection type (code)		
		17	37, 59, 80, 93	60
8	1/4"	8.19	-	8.19
10	3/8"	8.19	-	8.19
15	1/2"	21.06	10.53	21.06
20	3/4"	50.31	30.42	50.31
25	1"	90.09	65.52	90.09
32	1¼"	111.15	-	111.15
40	1½"	241.02	201.24	241.02
50	2"	402.48	382.59	402.48
65	2½"	704.34	603.72	704.34
80	3"	987.48	955.89	987.48
100	4"	1710.54	1609.92	1710.54

Cv values in gpm

Pressure rating:

DN	Connection type (code)			
	17	37, 59	60	80, 93
8	-	-	PN63	-
10	PN63	-	PN63	-
15	PN63	PN63	PN63	PN25
20	PN63	PN63	PN63	PN25
25	PN63	PN63	PN63	PN25
32	PN63	-	PN63	-
40	PN63	PN63	PN63	PN25
50	PN63	PN63	PN63	PN16
65	PN40	PN40	PN40	PN16
80	PN40	PN40	PN40	PN10
100	PN25	PN25	PN25	PN10





For clamp connections, the permissible pressures are designed for a temperature of 14 to 284 °F when using suitable clamps and sealing materials.

Product conformities

Pressure Equipment Directive: 2014/68/EU

Food: FDA
Regulation (EC) No. 1935/2004
Regulation (EC) No. 10/2011

Explosion protection: ATEX (2014/34/EU), order code Special version X

ATEX marking:
Up to DN 65
Gas:  II 2G Ex h IIC T6 ... T2 Gb X
Dust:  II -/2D Ex h -/IIIC T180 °C -/Db X
DN 80 and 100
Gas:  II 2G Ex h IIB T6 ... T2 Gb X
Dust:  II -/2D Ex h -/IIIC T180 °C -/Db X

Mechanical data**Torques:**

DN	NPS	Seal material (code)	
		5T	5H
8	1/4"	35.40	35.40
10	3/8"	35.40	35.40
15	1/2"	70.81	106.21
20	3/4"	70.81	106.21
25	1"	115.06	168.16
32	1¼"	141.61	194.72
40	1½"	283.22	415.99
50	2"	300.93	451.39
65	2½"	805.42	929.33
80	3"	920.48	1062.09
100	4"	1239.10	1849.81

Free of oil and grease incl. 25% safety
Torques in lbf in

Weight:

DN	NPS	Connection type (code)			
		17	37, 59	60	80, 93
8	1/4"	-	-	1.10	-
10	3/8"	-	-	1.10	-
15	1/2"	1.76	1.10	1.10	1.10
20	3/4"	1.76	1.10	1.76	1.10
25	1"	2.43	2.20	2.43	2.43
32	1¼"	3.53	-	3.53	-
40	1½"	5.95	4.63	5.95	4.85
50	2"	9.26	7.72	9.26	7.72
65	2½"	18.08	15.43	18.08	15.65
80	3"	25.57	24.25	25.57	26.01
100	4"	52.91	44.09	52.91	45.19

Weight in lb

Dimensions

Actuator flange

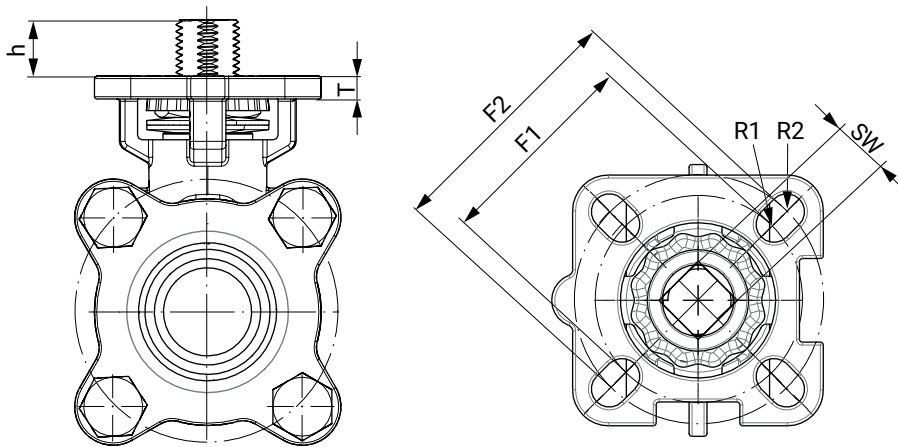

DN	G	F1	ISO 5211 (F1)	R1	F2	ISO 5211 (F2)	R2	SW [mm]	h	T
8	1/4"	1.42	F03	0.12	1.65	F04	0.12	9.0	0.35	0.20
10	3/8"	1.42	F03	0.12	1.65	F04	0.12	9.0	0.35	0.20
15	1/2"	1.42	F03	0.12	1.65	F04	0.12	9.0	0.35	0.20
20	3/4"	1.42	F03	0.12	1.65	F04	0.12	9.0	0.30	0.20
25	1"	1.65	F04	0.12	1.97	F05	0.14	11.0	0.51	0.28
32	1 1/4"	1.65	F04	0.12	1.97	F05	0.14	11.0	0.51	0.28
40	1 1/2"	1.97	F05	0.14	2.76	F07	0.18	14.0	0.59	0.35
50	2"	1.97	F05	0.14	2.76	F07	0.18	14.0	0.63	0.35
65	2 1/2"	1.97	F07	0.14	2.76	F10	0.18	17.0	0.71	0.41
80	3"	2.76	F07	0.18	4.02	F10	0.22	17.0	0.71	0.41
100	4"	4.02	F10	0.18	4.92	F12	0.22	22.0	1.02	0.41

Dimensions in inch

Body dimensions

Spigot DIN EN 10357 (connection code 17)

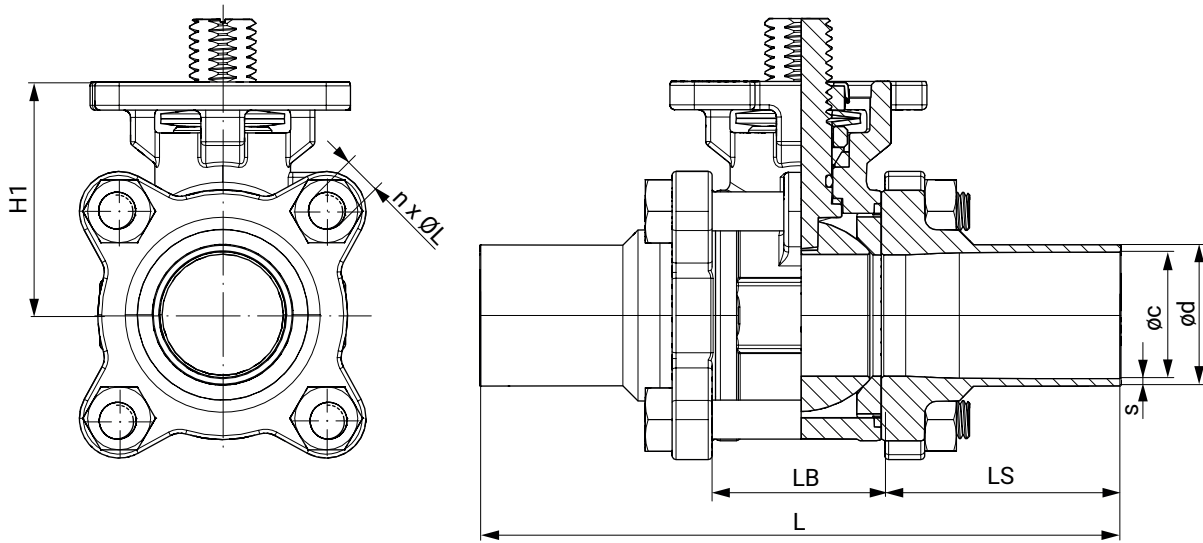

DN	Øc	Ød	L	LB	LS	H1	n x ØL	s
10	0.39	0.51	4.73	0.96	1.89	1.46	4 x M6	0.06
15	0.63	0.75	5.52	0.96	2.28	1.46	4 x M6	0.06
20	0.79	0.91	5.51	1.23	2.14	1.57	4 x M8	0.06
25	1.02	1.14	5.98	1.34	2.32	1.89	4 x M8	0.06
32	1.26	1.38	6.50	1.73	2.38	2.09	4 x M10	0.06
40	1.50	1.61	7.48	2.17	2.66	2.48	4 x M12	0.06
50	1.97	2.09	7.99	2.71	2.64	2.83	4 x M14	0.06
65	2.60	2.76	10.00	3.23	3.39	3.62	4 x M14	0.08
80	3.19	3.35	11.02	3.78	3.62	4.02	4 x M16	0.08
100	3.94	4.09	12.13	4.80	3.66	5.20	6 x M20	0.08

Dimensions in inch
n = number of bolts

Spigot SMS 3008 (connection code 37)

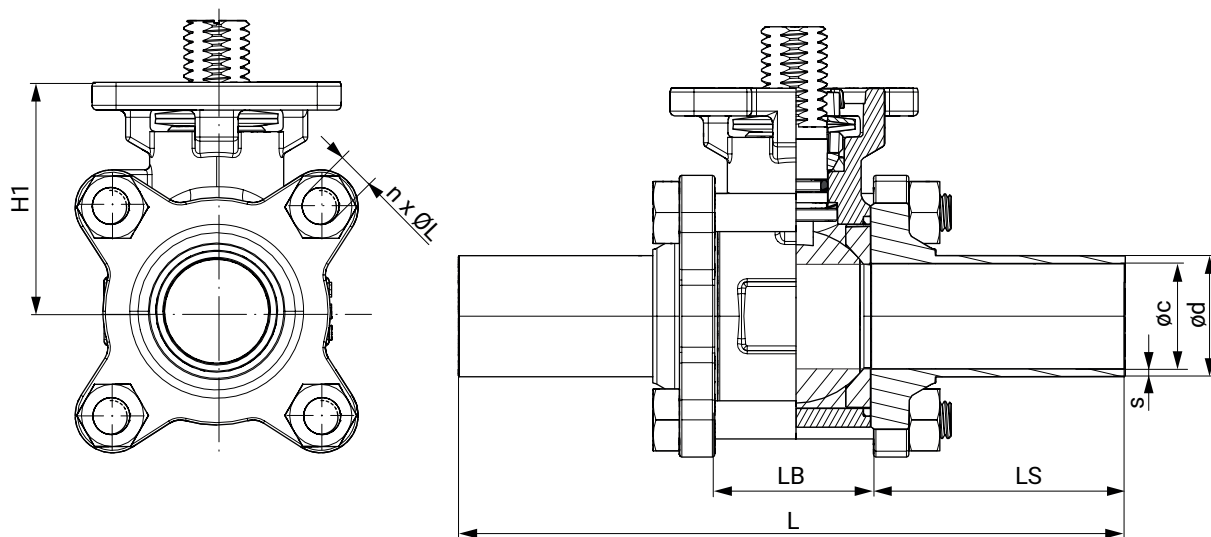

DN	øc	ød	s	t	L	LB	LS	H1	n x ØL
20	0.63	0.71	0.04	0.24	5.60	1.10	2.31	1.50	4 x M6
25	0.89	0.98	0.05	0.29	6.39	1.26	2.56	1.89	4 x M8
40	1.40	1.50	0.05	0.33	7.17	1.81	2.68	2.36	4 x M12
50	1.91	2.01	0.05	0.40	7.60	2.35	2.63	2.72	4 x M14
65	2.37	2.50	0.06	0.49	10.00	3.04	3.48	3.50	4 x M14
80	2.87	3.00	0.06	0.55	10.90	3.61	3.65	3.86	4 x M16
100	3.84	4.00	0.08	0.57	12.00	4.66	3.67	5.12	6 x M16

Dimensions in inch
n = number of bolts

Spigot ASME BPE (connection code 59)

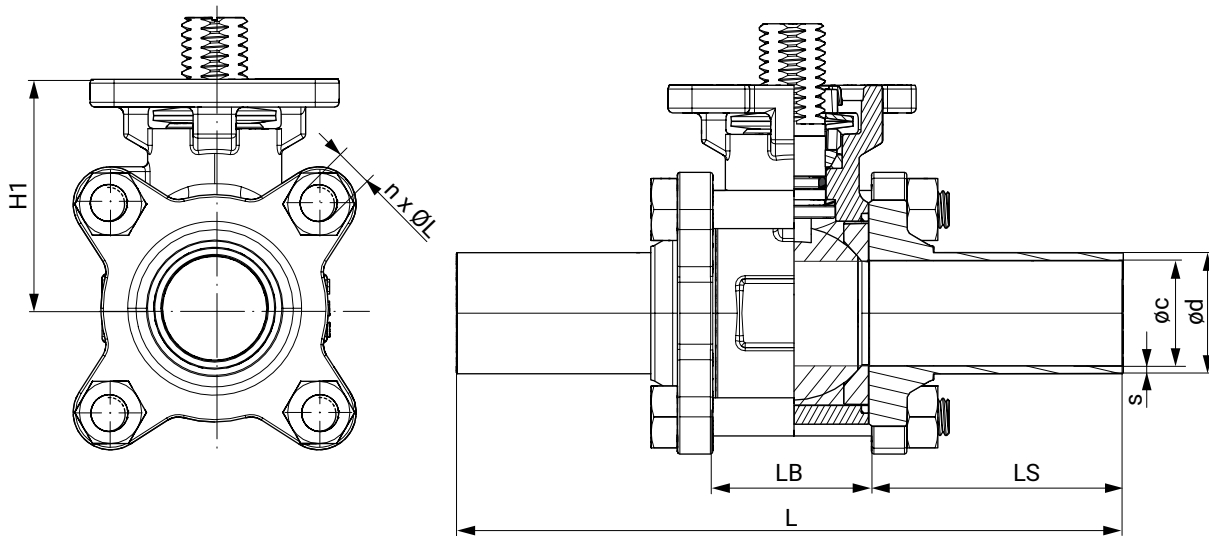

DN	Øc	Ød	s	L	LB	LS	H1	n x ØL
15	0.37	0.50	0.06	4.90	0.98	1.96	1.50	4 x M6
20	0.62	0.75	0.06	5.60	1.10	2.31	1.50	4 x M6
25	0.87	1.00	0.06	6.39	1.26	2.56	1.89	4 x M8
40	1.37	1.50	0.06	7.17	1.81	2.68	2.36	4 x M12
50	1.87	2.00	0.06	7.60	2.35	2.63	2.72	4 x M14
65	2.37	2.50	0.06	10.00	3.04	3.48	3.50	4 x M14
80	2.87	3.00	0.06	10.90	3.61	3.65	3.86	4 x M16
100	3.83	4.00	0.08	12.00	4.66	3.67	5.12	6 x M16

Dimensions in inch
n = number of bolts

Spigot ISO 1127 / EN 10357 (connection code 60)

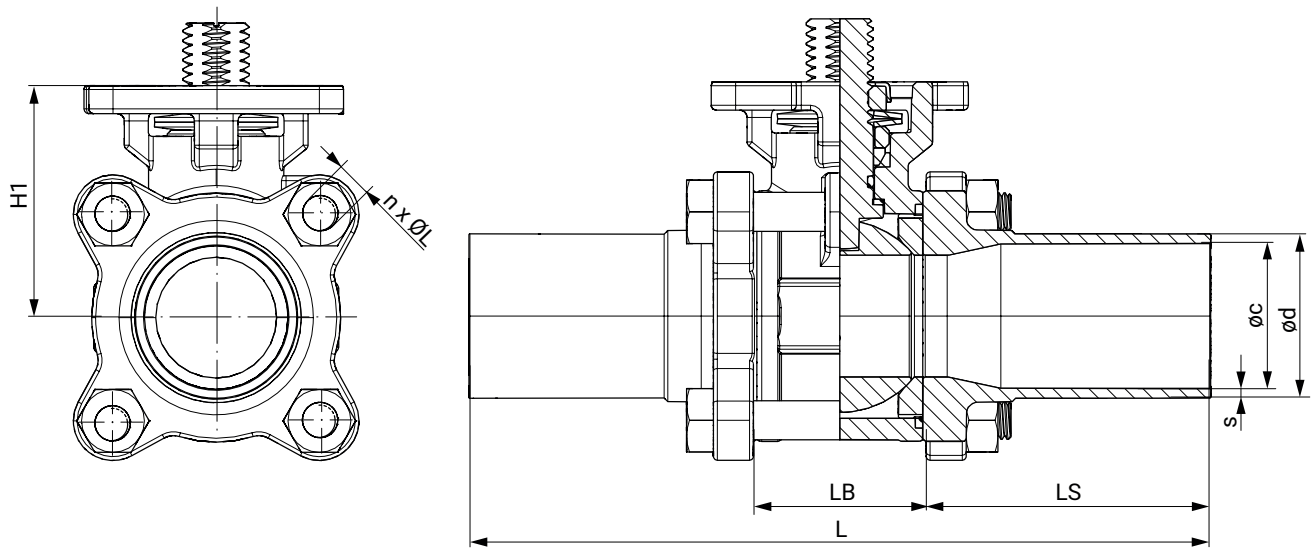

DN	øc	ød	s	L	LB	LS	H1	n x ØL
8	0.41	0.53	0.06	4.73	0.96	1.89	1.46	4 x M6
10	0.55	0.68	0.06	4.73	0.96	1.89	1.46	4 x M6
15	0.71	0.84	0.06	5.52	0.96	2.28	1.46	4 x M6
20	0.93	1.06	0.06	5.51	1.23	2.14	1.57	4 x M8
25	1.17	1.33	0.08	5.98	1.34	2.32	1.89	4 x M8
32	1.51	1.67	0.08	6.50	1.73	2.38	2.09	4 x M10
40	1.74	1.90	0.08	7.48	2.17	2.66	2.48	4 x M12
50	2.22	2.37	0.08	7.99	2.71	2.64	2.83	4 x M14
65	2.84	3.00	0.08	10.00	3.23	3.39	3.62	4 x M14
80	3.32	3.50	0.09	11.02	3.78	3.62	4.02	4 x M16
100	4.32	4.50	0.09	12.13	4.80	3.66	5.20	6 x M20

Dimensions in inch
n = number of bolts

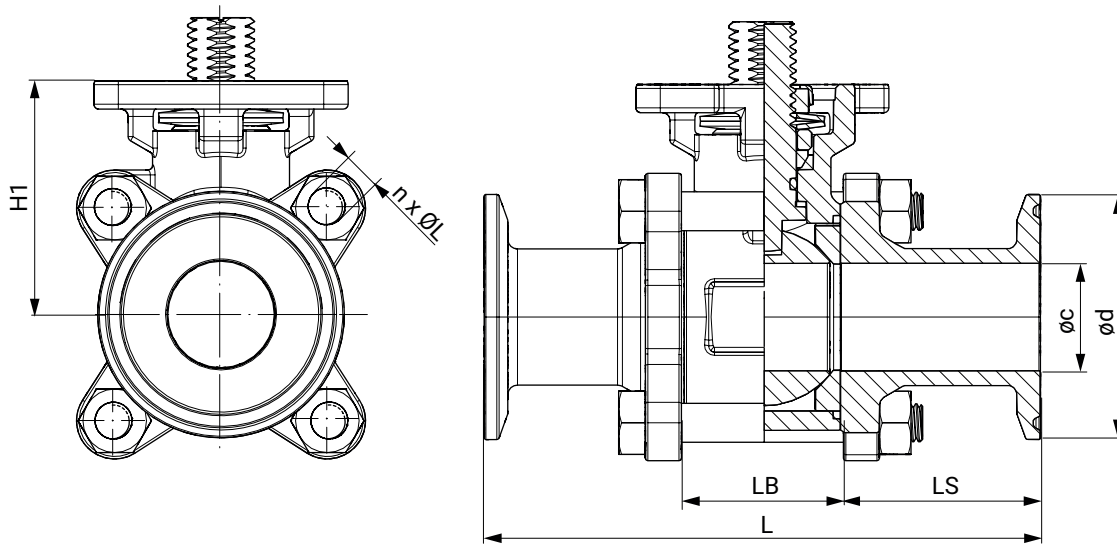
Clamp ASME BPE (connection code 80)

DN	øc	ød	s	L	LB	LS	H1	n x ØL
15	0.37	0.98	0.06	3.50	0.98	1.26	1.50	4 x M6
20	0.62	0.98	0.06	4.00	0.98	1.51	1.50	4 x M6
25	0.87	1.98	0.06	4.50	1.26	1.62	1.89	4 x M8
40	1.37	1.98	0.06	5.50	1.81	1.85	2.36	4 x M12
50	1.87	2.52	0.06	6.25	2.35	1.95	2.72	4 x M14
65	2.37	3.05	0.06	6.75	3.04	1.86	3.50	4 x M14
80	2.87	3.58	0.06	7.73	3.61	2.06	3.86	4 x M16
100	3.83	4.68	0.08	9.50	4.66	2.42	5.12	6 x M16

Dimensions in inch
n = number of bolts

Mixed ends ASME BPE (connection code 93)

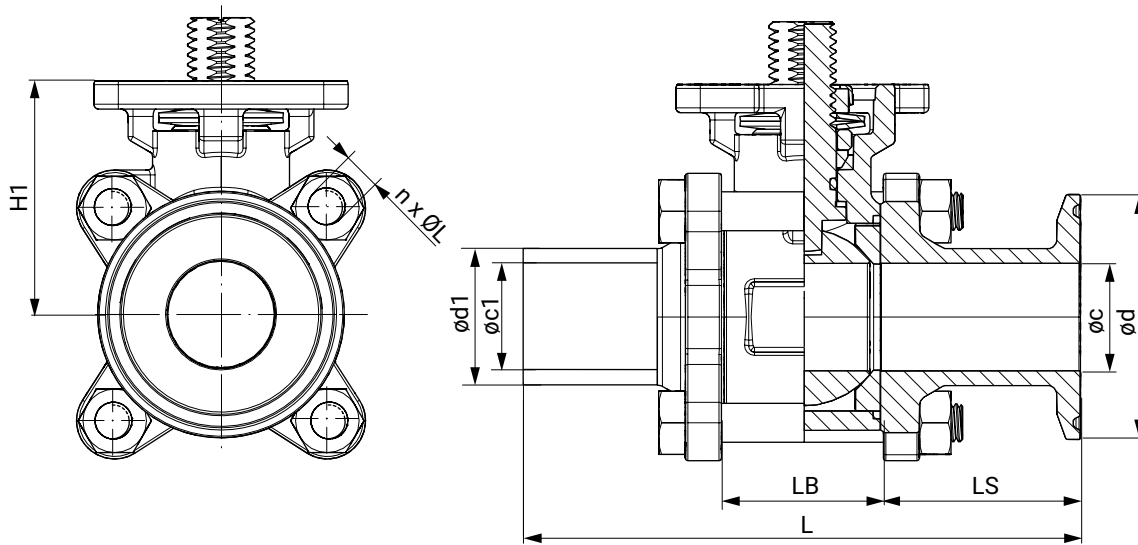

DN	øc	ød	øc1	ød1	s	t	L	LB	LS	H1	n x ØL
15	0.37	0.98	0.37	0.50	0.06	0.24	4.20	0.98	1.96	1.50	4 x M6
20	0.62	0.98	0.62	0.75	0.06	0.24	4.80	1.10	2.31	1.50	4 x M6
25	0.87	1.98	0.87	1.00	0.06	0.29	5.44	1.26	2.56	1.89	4 x M8
40	1.37	1.98	1.37	1.50	0.06	0.33	6.34	1.81	2.68	2.36	4 x M12
50	1.87	2.52	1.87	2.00	0.06	0.40	6.93	2.35	2.63	2.72	4 x M14
65	2.37	3.05	2.37	2.50	0.06	0.49	8.38	3.04	3.48	3.50	4 x M14
80	2.87	3.58	2.87	3.00	0.06	0.55	9.31	3.61	3.65	3.86	4 x M16
100	3.83	4.68	3.83	4.00	0.08	0.57	10.75	4.66	3.67	5.12	6 x M16

Dimensions in inch
n = number of bolts

Add-on components



GEMÜ DR

Pneumatic quarter turn actuator

GEMÜ DR is a pneumatic double acting quarter turn actuator. It works according to the double piston rack and pinion principle and is suitable for mounting to butterfly valves or ball valves.



GEMÜ SC

Pneumatic quarter turn actuator

GEMÜ SC is a pneumatic single acting quarter turn actuator. It works according to the double piston rack and pinion principle and is suitable for mounting to butterfly valves or ball valves.



GEMÜ ADA

Pneumatic quarter turn actuator

GEMÜ ADA is a pneumatic double acting quarter turn actuator. It works according to the double piston rack and pinion principle and is suitable for mounting to butterfly valves or ball valves.



GEMÜ ASR

Pneumatic quarter turn actuator

GEMÜ ASR is a pneumatic single acting quarter turn actuator. It works according to the double piston rack and pinion principle and is suitable for mounting to butterfly valves or ball valves.



GEMÜ 9428

Motorized quarter turn actuator

The product is a motorized quarter turn actuator. The actuator is designed for DC or AC operating voltages. A manual override and an optical position indicator are integrated as standard. The torque in the end positions is increased. This enables a closing curve matched to the valves.



GEMÜ J4C

Motorized quarter turn actuator

The J4C actuator is a motorized quarter turn actuator. The motor is designed for DC and AC operating voltages. A manual override and an optical position indicator are integrated as standard. The end positions are potential-free and adjustable.

GEMÜ AB24



Hand lever or gearbox with handwheel

Hand lever with standard flange according to EN ISO 5211 for the manual operation of quarter turn valves.

Accessories

GEMÜ RC0

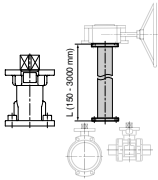

Shaft extension

The RC0 shaft extension for quarter turn valves is a distance piece between manually, pneumatically or electrically operated valves. This means that valves can be protected from flooding or better access for operation of the valve can be ensured (also for manual override).

Nominal size	GEMÜ RC0 shaft extension		GEMÜ AB22 and AB24 hand lever	
	Item no.	Designation	Item no.	Designation
DN 8–20	88742081	RC0VAF04 D09KF04 D09 60 M12	88658096	AB22 20D OSET
DN 25–32	88742082	RC0VAF05 D11KF05 D11 65 M14	88658097	AB22 32D OSET
DN 40–50	88742083	RC0VAF07 D14KF07 D14 80 M18	88658099	AB22 50D OSET
DN 65	88742085	RC0VAF07 D17KF07 D17100 M22	88660113	AB26 65D OSET
DN 80	88742085	RC0VAF07 D17KF07 D17100 M22	88660114	AB26 80D OSET
DN 100	88781980	RC0VAF12 D22KF12 D22 75 M28	88660420	AB24 100D OSET



GEMÜ MSC

Mounting kit

The MSC mounting kit is an interface, for the same and different ends, to join flange designs according to ISO 5211. This mounting kit ensures thermal separation of actuator and valve body. It can also be used as height compensation for insulated pipelines. The mounting kit is available in steel, electrogalvanized and stainless steel in an open or closed design.

GEMÜ ADH

Mounting sleeve

The mounting sleeve accessories are available in the square and star geometry designs. These are used for the shaft and hub support for quarter turn actuators. Both sleeves have an internal square drive (please observe stated measurement dimensions here). The sleeve material is sintered metal and they are chemically nickel plated with a surface of 25 µm.

Certificates

Certificate	Standard	Item number
2.2 Ferrite content measurement		88081058
2.2 Surface roughness measurement	EN10204 - EN ISO 4288	88079146

Certificate	Standard	Item number
3.1 Surface roughness measurement		88094384
3.1 Material	EN 10204	88333336



GEMÜ Gebr. Müller Apparatebau GmbH & Co. KG
Fritz-Müller-Straße 6-8, 74653 Ingelfingen-Criesbach, Germany
Tel. +49 (0)7940 123-0 · info@gemue.de
www.gemu-group.com