

GEMÜ BB06

Compact flanged ball valve with bare shaft



Features

- High flow rate
- Full-flow bore
- Compact design
- ATEX version available as an option

Description

The GEMÜ BB06 metal one-piece 2/2-way ball valve has a bare shaft. The seat seal is made of PTFE.

Technical specifications

- **Media temperature:** -40 to 180 °C
- **Ambient temperature:** -40 to 60 °C
- **Operating pressure :** 0 to 40 bar
- **Nominal sizes:** DN 15 to 100
- **Body configurations:** 2/2-way body
- **Ball configurations:** Control ball
- **Connection types:** Flange
- **Connection standards:** ANSI | EN
- **Body materials:** 1.4408, investment casting material
- **Seal materials:** PTFE
- **Conformities:** ATEX | EAC | FDA | Functional safety | Reg. (EU) No. 10/2011 | Regulation (EC) No. 1935/2004 | Regulation (EC) No. 2023/2006 | TA Luft (German Clean Air Act)

Technical data depends on the respective configuration



further information
webcode: GW-BB06



Product line



GEMÜ BB06

GEMÜ B26

GEMÜ B46

GEMÜ B56

Operation

| | | | | |
|---------------------------|---------------|---------------|---------------|---------------|
| With bare shaft | ● | - | - | - |
| Manual | - | ● | - | - |
| Pneumatic | - | - | ● | - |
| Motorized | - | - | - | ● |
| Nominal sizes | DN 15 to 100 | DN 15 to 100 | DN 15 to 100 | DN 15 to 100 |
| Media temperature | -40 to 180 °C | -20 to 180 °C | -20 to 180 °C | -20 to 180 °C |
| Operating pressure | 0 to 40 bar | 0 to 40 bar | 0 to 40 bar | 0 to 40 bar |
| Connection types | | | | |
| Flange | ● | ● | ● | ● |

Product description

Construction

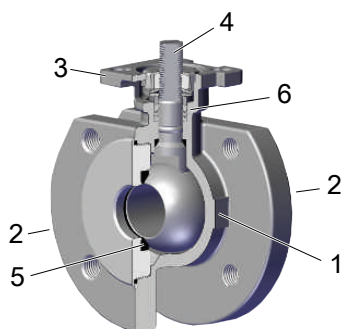

| Item | Name | Materials |
|------|--------------------------|----------------|
| 1 | Ball valve body | 1.4408 / CF8M |
| 2 | Pipe connections | 1.4408 / CF8M |
| 3 | Mounting flange ISO 5211 | 1.4408 / CF8M |
| 4 | Ball valve shaft | 1.4401 / SS316 |
| 5 | Seal | PTFE |
| 6 | Antistatic unit | 1.4408 |

Pressure-relief hole

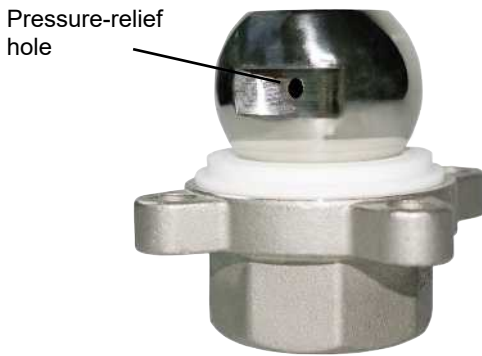

Control ball

| Control ball | Code U | Code Y | Code W |
|--------------|--------|--------|--------|
| | | | |

Note: The control ball cannot be retrofitted to standard 2/2-way bodies at a later date.

The spindle seal system

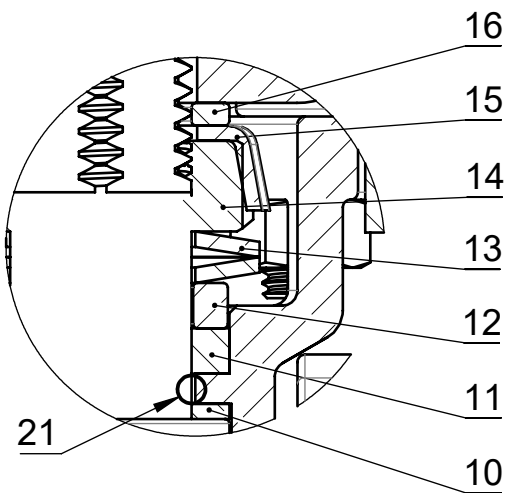

| Item | Name | Material |
|------|------------------------|--------------|
| 10 | Seal | PTFE |
| 11 | V-ring | PTFE |
| 12 | Stainless steel sleeve | SS304-1.4301 |
| 13 | Spring washer | SS304-1.4301 |
| 14 | Spindle nut | A2 70 |
| 15 | Cap | SS304-1.4301 |

The spindle seal system

| Item | Name | Material |
|------|-----------------------|--------------|
| 16 | Washer | SS304-1.4301 |
| 21 | O-ring (spindle seal) | Viton |

Long service life due to triple spindle seal

- Conical spindle seal:

The seal **10** arranged at an angle of 45° effectively prevents the leakage of media when operating the spindle

- O-ring:

Stabilising spindle seal **21** with low wear and long service life

- Pretensioned self-adjusting spindle seal:

The spindle packing consists of several V-rings **11**, a spring washer **13** and a stainless steel sleeve **12**. The spring washer **13** is pretensioned via the spindle nut **14**. The pretension force is distributed to the V-rings **11** via the stainless steel sleeve **12**, thereby preventing the leakage of media. The pretension provides low maintenance and reliable spindle sealing even after a long service life.

Application

- Heating systems
- Beverage industry
- Foodstuff industry
- Chemical industry
- Drinking water installations
- Processing industry
- HVAC

Order data

The order data provide an overview of standard configurations.

Please check the availability before ordering. Other configurations available on request.

Products ordered with **bold marked ordering options** are so-called preferred series. Depending on the nominal size, these are available more quickly.

Order codes

| 1 Type | Code | 5 Ball valve material | Code |
|--|-----------|---|-----------|
| Ball valve body, metal, one-piece body, compact flange, ISO 5211, top flange, low-maintenance spindle seal and blow-out proof shaft, with anti-static unit | BB06 | 1.4408 / CF8M (body, connection), 1.4401 / SS316 (ball, shaft) | 37 |
| 2 DN | Code | 6 Seal material | Code |
| DN 15 | 15 | PTFE | 5 |
| DN 20 | 20 | 7 Type of design | Code |
| DN 25 | 25 | Standard | |
| DN 32 | 32 | Thermal separation between actuator and valve body via mounting kit | 5222 |
| DN 40 | 40 | Thermal separation between actuator and valve body via mounting kit, mounting kit and mounting parts made from stainless steel | 5227 |
| DN 50 | 50 | K-no. 5227, K-no. 7056, 5227 - Thermal separation via mounting kit, 7056 - Drilled shaft, shortened hand lever | 5237 |
| DN 65 | 65 | Hand lever shortened to set up feedback units. Shaft face drilled for mounting kit: DN8-DN20 M5 X 12,5 / depth of thread 9.0mm, DN25-DN100 M6 x 15 / depth of thread 10.0mm | 7056 |
| DN 80 | 80 | 8 Special version | Code |
| DN 100 | 100 | Without | |
| 3 Body/ball configuration | Code | ATEX certification | X |
| 2/2-way body | D | 9 CONEXO | Code |
| 2/2-way body, V-ball 30° (for Kv value see datasheet) | U | Without | |
| 2/2-way body, V-ball 60° (for Kv value see datasheet) | Y | Integrated RFID chip for electronic identification and traceability | C |
| 2/2-way body, V-ball 90° (for Kv value see datasheet) | W | 4 Connection type | Code |
| 4 Connection type | Code | Flange ANSI Class 125/150 RF, face-to-face dimension FTF EN 558 series 1, ISO 5752, basic series 1, length only for body configuration D | 39 |
| Flange EN 1092, PN16/PN40, form B DN15 to DN50, flange EN1092, PN 16, form B DN65 to DN100 | 68 | | |

Order example

| Ordering option | Code | Description |
|---------------------------|------|--|
| 1 Type | BB06 | Ball valve body, metal, one-piece body, compact flange, ISO 5211, top flange, low-maintenance spindle seal and blow-out proof shaft, with anti-static unit |
| 2 DN | 25 | DN 25 |
| 3 Body/ball configuration | D | 2/2-way body |
| 4 Connection type | 39 | Flange ANSI Class 125/150 RF |
| 5 Ball valve material | 37 | 1.4408 / CF8M (body, connection), 1.4401 / SS316 (ball, shaft) |
| 6 Seal material | 5 | PTFE |
| 7 Type of design | | Without |
| 8 Special version | | Standard |

| Ordering option | Code | Description |
|-----------------|------|-------------|
| 9 CONEXO | | Without |

Technical data

Medium

Working medium: Corrosive, inert, gaseous and liquid media and steam which have no negative impact on the physical and chemical properties of the body and seal material.

Temperature

Media temperature: -40 – 180 °C
For media temperatures > 100 °C, we recommend using a mounting kit with adapter between the ball valve and the actuator.

Ambient temperature: -40 – 60 °C
Higher temperatures on request

Storage temperature: -60 – 60 °C

Pressure

Operating pressure: 0 – 40 bar

Vacuum: Can be used up to a vacuum of 50 mbar (absolute)
These values apply to room temperature and air. The values may deviate for other media and other temperatures.

Leakage rate: Leakage rate according to ANSI FCI70 – B16.104
Leakage rate according to EN12266, 6 bar air, leakage rate A

Pressure/temperature diagram:

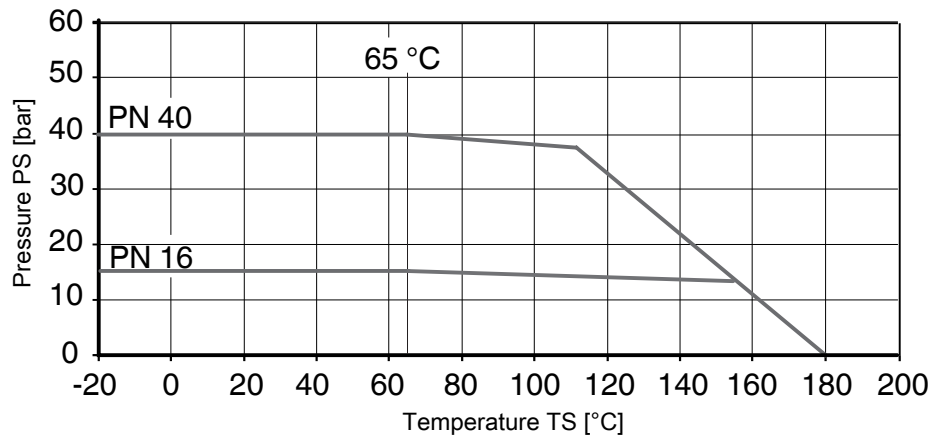

Pressure/temperature data according to the diagram refer to static operating conditions. Strongly fluctuating parameters or parameters that change quickly over time can lead to a reduction in service life. Special applications are to be discussed with your technical contact in advance.

Pressure rating: DN 15 – 50: PN40
DN 65 – 100: PN16

Kv values:

| DN | NPS | Kv values |
|-----|------|-----------|
| 15 | 1/2" | 13.0 |
| 20 | 3/4" | 34.0 |
| 25 | 1" | 60.0 |
| 32 | 1¼" | 94.0 |
| 40 | 1½" | 213.0 |
| 50 | 2" | 366.0 |
| 65 | 2½" | 595.0 |
| 80 | 3" | 935.0 |
| 100 | 4" | 1700.0 |

Kv values in m³/h

V-ball 30° (code U)

| DN | NPS | Opening angle | | | | | | | | | | |
|-----|------|---------------|-------|-------|-------|--------|--------|--------|--------|--------|--------|--------|
| | | 0 | 15% | 20% | 30% | 40% | 50% | 60% | 70% | 80% | 90% | 100% |
| 15 | 1/2" | 0 | 0.085 | 0.085 | 0.170 | 0.255 | 0.425 | 0.680 | 0.935 | 1.360 | 1.870 | 2.210 |
| 20 | 3/4" | 0 | 0.085 | 0.170 | 0.425 | 0.595 | 0.935 | 1.530 | 2.040 | 2.805 | 3.825 | 4.590 |
| 25 | 1" | 0 | 0.085 | 0.255 | 0.680 | 1.105 | 1.955 | 2.975 | 4.335 | 5.961 | 8.128 | 8.500 |
| 32 | 1¼" | 0 | 0.170 | 0.340 | 0.935 | 1.700 | 3.145 | 4.675 | 6.800 | 8.500 | 11.050 | 12.750 |
| 40 | 1½" | 0 | 0.255 | 0.510 | 1.360 | 2.550 | 4.250 | 6.375 | 9.350 | 11.900 | 14.450 | 17.000 |
| 50 | 2" | 0 | 0.340 | 1.020 | 3.230 | 5.100 | 8.500 | 12.75 | 19.550 | 26.350 | 36.550 | 51.000 |
| 65 | 2½" | 0 | 0.340 | 0.850 | 3.400 | 6.800 | 10.200 | 15.300 | 23.800 | 31.450 | 52.70 | 63.750 |
| 80 | 3" | 0 | 0.425 | 1.020 | 3.400 | 6.800 | 11.900 | 19.550 | 28.050 | 39.100 | 55.250 | 69.700 |
| 100 | 4" | 0 | 0.510 | 1.700 | 5.100 | 12.750 | 24.650 | 40.800 | 60.350 | 85.000 | 110.50 | 135.20 |

Kv values in m³/h

V-ball 60° (code Y)

| DN | NPS | Opening angle | | | | | | | | | | |
|-----|------|---------------|-------|-------|-------|--------|--------|--------|--------|-------|--------|--------|
| | | 0 | 15% | 20% | 30% | 40% | 50% | 60% | 70% | 80% | 90% | 100% |
| 15 | 1/2" | 0 | 0.085 | 0.085 | 0.255 | 0.425 | 0.765 | 1.190 | 1.700 | 2.805 | 3.740 | 5.100 |
| 20 | 3/4" | 0 | 0.085 | 0.170 | 0.595 | 0.850 | 1.445 | 2.380 | 3.400 | 5.525 | 7.650 | 10.200 |
| 25 | 1" | 0 | 0.170 | 0.340 | 0.935 | 1.530 | 2.890 | 4.505 | 6.715 | 10.46 | 13.010 | 17.850 |
| 32 | 1¼" | 0 | 0.170 | 0.510 | 1.530 | 2.550 | 4.675 | 8.075 | 10.880 | 16.15 | 22.100 | 33.150 |
| 40 | 1½" | 0 | 0.340 | 0.680 | 2.125 | 3.400 | 6.800 | 11.050 | 16.150 | 22.95 | 34.000 | 44.200 |
| 50 | 2" | 0 | 0.340 | 1.275 | 3.910 | 7.650 | 14.030 | 22.950 | 33.150 | 46.75 | 70.550 | 93.500 |
| 65 | 2½" | 0 | 0.340 | 1.275 | 4.250 | 8.500 | 17.850 | 28.900 | 45.050 | 63.75 | 87.550 | 127.50 |
| 80 | 3" | 0 | 0.425 | 2.125 | 5.100 | 11.900 | 21.250 | 34.000 | 55.250 | 77.35 | 108.80 | 140.30 |
| 100 | 4" | 0 | 0.595 | 2.550 | 9.350 | 21.250 | 34.000 | 50.150 | 76.500 | 119.9 | 180.20 | 302.60 |

Kv values in m³/h

Kv values:

V-ball 90° (code W)

| DN | NPS | Opening angle | | | | | | | | | | |
|-----|------|---------------|-------|-------|--------|--------|--------|--------|--------|--------|--------|--------|
| | | 0 | 15% | 20% | 30% | 40% | 50% | 60% | 70% | 80% | 90% | 100% |
| 15 | 1/2" | 0 | 0.085 | 0.170 | 0.340 | 0.510 | 0.765 | 1.275 | 1.870 | 3.230 | 4.590 | 5.865 |
| 20 | 3/4" | 0 | 0.170 | 0.340 | 0.680 | 1.020 | 1.700 | 2.635 | 3.910 | 6.800 | 9.605 | 11.900 |
| 25 | 1" | 0 | 0.170 | 0.510 | 1.530 | 2.890 | 4.335 | 6.885 | 9.690 | 13.600 | 17.850 | 24.650 |
| 32 | 1¼" | 0 | 0.255 | 0.680 | 1.700 | 4.250 | 6.800 | 11.900 | 16.150 | 23.800 | 33.150 | 46.750 |
| 40 | 1½" | 0 | 0.425 | 0.765 | 2.975 | 5.950 | 11.050 | 17.000 | 26.350 | 35.700 | 53.550 | 66.300 |
| 50 | 2" | 0 | 0.595 | 1.700 | 5.100 | 10.200 | 18.700 | 29.750 | 38.250 | 59.500 | 89.250 | 114.80 |
| 65 | 2½" | 0 | 0.425 | 1.445 | 5.950 | 11.900 | 23.800 | 40.800 | 59.500 | 90.100 | 136.00 | 185.30 |
| 80 | 3" | 0 | 0.595 | 2.975 | 6.800 | 15.300 | 29.750 | 51.000 | 76.500 | 114.80 | 174.30 | 263.50 |
| 100 | 4" | 0 | 0.850 | 2.975 | 13.600 | 34.000 | 63.750 | 106.30 | 161.50 | 250.80 | 375.70 | 569.50 |





Kv values in m³/h

Product conformities

Pressure Equipment Directive: 2014/68/EU

Food: FDA
Regulation (EC) No. 10/2011
Regulation (EC) No. 1935/2006

Explosion protection: ATEX (2014/34/EU) and IECEx, order code Special version X

ATEX marking: **Up to DN 65**
Gas:  II 2G Ex h IIC T6 ... T2 Gb X
Dust:  II -/2D Ex h -/IIIC T180 °C -/Db X
DN 80 and 100
Gas:  II 2G Ex h IIB T6 ... T2 Gb X
Dust:  II -/2D Ex h -/IIIC T180 °C -/Db X

Mechanical data

Torques:

| DN | NPS | Breakaway torque |
|-----|------|------------------|
| 15 | 1/2" | 7 |
| 20 | 3/4" | 8 |
| 25 | 1" | 10 |
| 32 | 1¼" | 14 |
| 40 | 1½" | 29 |
| 50 | 2" | 58 |
| 65 | 2½" | 62 |
| 80 | 3" | 120 |
| 100 | 4" | 174 |

Torques in Nm

Weight:

Ball valve

| DN | NPS | Weight |
|-----|------|--------|
| 15 | 1/2" | 1.3 |
| 20 | 3/4" | 2.0 |
| 25 | 1" | 2.8 |
| 32 | 1¼" | 4.2 |
| 40 | 1½" | 5.3 |
| 50 | 2" | 6.7 |
| 65 | 2½" | 11.9 |
| 80 | 3" | 14.9 |
| 100 | 4" | 20.4 |

Weights in kg

Dimensions

Actuator flange

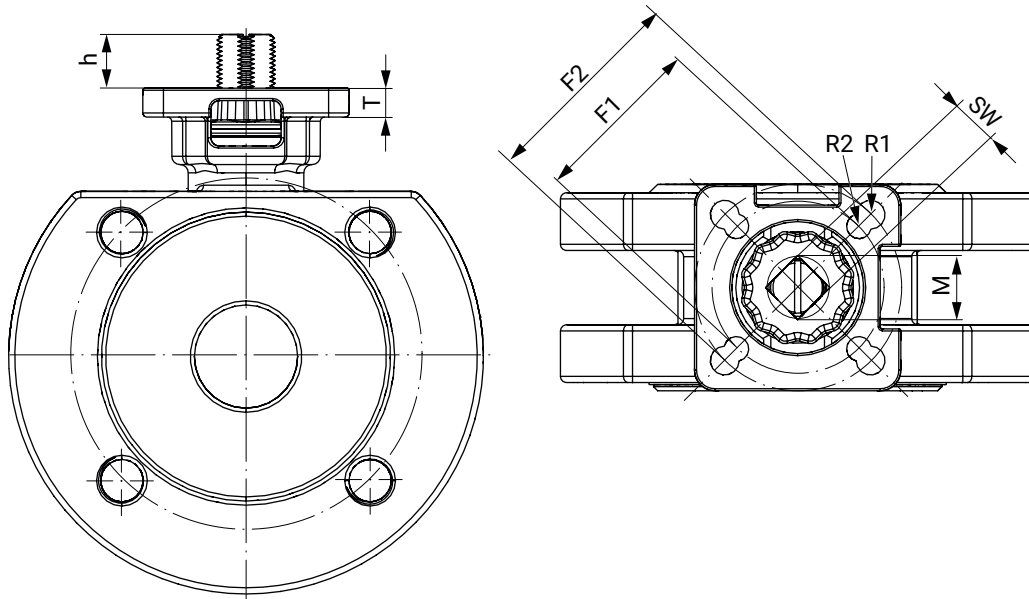

| DN | G | F1 | R1 | F2 | R2 | SW | h | T | M |
|-----|------|------|-----|-------|-----|------|------|------|-----|
| 15 | 1/2" | 36.0 | 3.0 | 42.0 | 3.0 | 9.0 | 9.0 | 5.0 | M12 |
| 20 | 3/4" | 36.0 | 3.0 | 42.0 | 3.0 | 9.0 | 7.5 | 5.0 | M12 |
| 25 | 1" | 42.0 | 3.0 | 50.0 | 3.5 | 11.0 | 13.0 | 7.0 | M14 |
| 32 | 1¼" | 42.0 | 3.0 | 50.0 | 3.5 | 11.0 | 13.0 | 7.0 | M14 |
| 40 | 1½" | 50.0 | 3.5 | 70.0 | 4.5 | 14.0 | 15.0 | 9.0 | M18 |
| 50 | 2" | 50.0 | 3.5 | 70.0 | 4.5 | 14.0 | 16.0 | 9.0 | M18 |
| 65 | 2½" | 70.0 | 5.0 | 102.0 | 6.0 | 17.0 | 18.0 | 10.5 | M22 |
| 80 | 3" | 70.0 | 5.0 | 102.0 | 6.0 | 17.0 | 18.0 | 10.5 | M22 |
| 100 | 4" | 70.0 | 5.0 | 102.0 | 6.0 | 17.0 | 18.0 | 10.5 | M22 |

Dimensions in mm

Body dimensions

Flange (connection code 39)

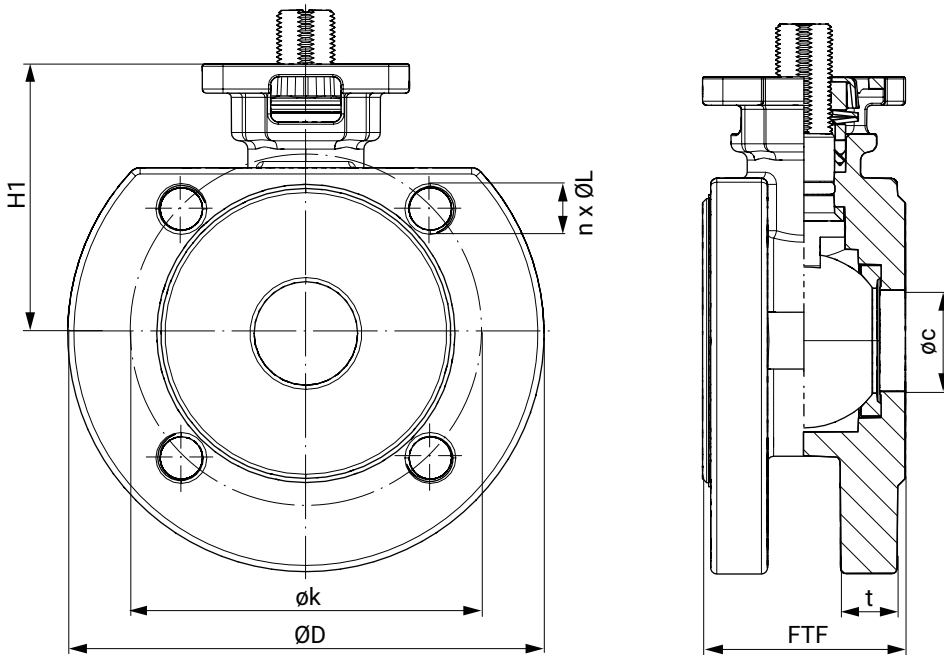

| DN | øc | ØD | øk | t | FTF | H1 | n x ØL |
|-----|-------|-------|-------|------|-------|-------|-------------|
| 15 | 15.0 | 89.0 | 60.5 | 9.2 | 38.0 | 48.5 | 4x1/2-13UNC |
| 20 | 20.0 | 99.0 | 69.8 | 11.0 | 40.0 | 54.0 | 4x1/2-13UNC |
| 25 | 25.0 | 108.0 | 79.2 | 13.5 | 46.0 | 65.0 | 4x1/2-13UNC |
| 32 | 32.0 | 117.0 | 88.9 | 14.0 | 56.0 | 78.0 | 4x1/2-13UNC |
| 40 | 38.0 | 127.0 | 98.6 | 15.5 | 65.0 | 85.0 | 4x1/2-13UNC |
| 50 | 50.0 | 152.0 | 120.6 | 17.0 | 78.0 | 93.0 | 4x5/8-11UNC |
| 65 | 65.0 | 178.0 | 139.7 | 20.5 | 99.0 | 107.0 | 4x5/8-11UNC |
| 80 | 76.0 | 190.0 | 152.4 | 22.0 | 116.0 | 119.0 | 4x5/8-11UNC |
| 100 | 100.0 | 229.0 | 190.5 | 22.0 | 149.0 | 132.0 | 8x5/8-11UNC |

Dimensions in mm

Flange (connection code 68)

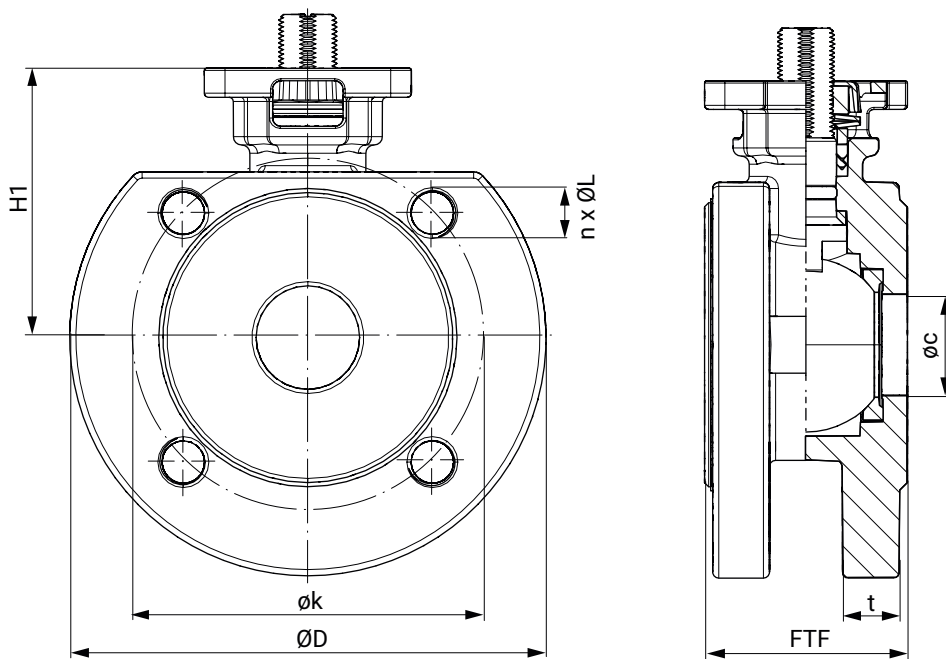

| DN | øc | ØD | øk | t | FTF | H1 | n x ØL |
|-----|-------|-------|-------|------|-------|-------|---------|
| 15 | 15.0 | 82.0 | 65.0 | 14.0 | 42.0 | 48.5 | 4 x M12 |
| 20 | 20.0 | 98.0 | 75.0 | 14.0 | 44.0 | 54.0 | 4 x M12 |
| 25 | 25.0 | 115.0 | 85.0 | 14.0 | 50.0 | 65.0 | 4 x M12 |
| 32 | 32.0 | 140.0 | 100.0 | 16.0 | 60.0 | 78.0 | 4 x M16 |
| 40 | 38.0 | 150.0 | 110.0 | 15.0 | 69.0 | 85.0 | 4 x M16 |
| 50 | 50.0 | 165.0 | 125.0 | 15.5 | 82.0 | 93.0 | 4 x M16 |
| 65 | 65.0 | 185.0 | 145.0 | 15.5 | 103.0 | 107.0 | 4 x M16 |
| 80 | 76.0 | 200.0 | 160.0 | 17.0 | 119.0 | 119.0 | 8 x M16 |
| 100 | 100.0 | 220.0 | 180.0 | 17.0 | 150.0 | 132.0 | 8 x M16 |

Dimensions in mm

Add-on components



GEMÜ ADA

Pneumatic quarter turn actuator

GEMÜ ADA is a pneumatic double acting quarter turn actuator. It works according to the double piston rack and pinion principle and is suitable for mounting to butterfly valves or ball valves.



GEMÜ ASR

Pneumatic quarter turn actuator

GEMÜ ASR is a pneumatic single acting quarter turn actuator. It works according to the double piston rack and pinion principle and is suitable for mounting to butterfly valves or ball valves.



GEMÜ 9428

Motorized quarter turn actuator

The product is a motorized quarter turn actuator. The actuator is designed for DC or AC operating voltages. A manual override and an optical position indicator are integrated as standard. The torque in the end positions is increased. This enables a closing curve matched to the valves.



GEMÜ J4C

Motorized quarter turn actuator

The J4C actuator is a motorized quarter turn actuator. The motor is designed for DC and AC operating voltages. A manual override and an optical position indicator are integrated as standard. The end positions are potential-free and adjustable.



GEMÜ AB26

Hand lever or gearbox with handwheel

Hand lever with standard flange according to EN ISO 5211 for the manual operation of quarter turn valves.



GEMÜ LSR

Electrical position indicators for quarter turn actuators

The GEMÜ LS series electrical position indicators are used to feed back and verify the position of quarter turn valves. Depending on the version, they have either one or two mechanical microswitches or 2-wire or 3-wire proximity switches.



GEMÜ LSC

Limit switch box for quarter turn actuators

The GEMÜ LSC limit switch box is suitable for mounting to manually and pneumatically operated quarter turn valves. It is also fitted with an optical position indicator for visual confirmation of position.

Accessories

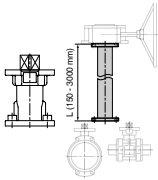

GEMÜ RC0

Shaft extension

The RC0 shaft extension for quarter turn valves is a distance piece between manually, pneumatically or electrically operated valves. This means that valves can be protected from flooding or better access for operation of the valve can be ensured (also for manual override).

| Nominal size | GEMÜ RC0 shaft extension | | GEMÜ AB22 hand lever | |
|--------------|--------------------------|-----------------------------|----------------------|---------------|
| | Item no. | Designation | Item no. | Designation |
| DN 15 - 20 | 88742081 | RC0VAF04 D09KF04 D09 60 M12 | 88658096 | AB22 20D 0SET |
| DN 25 - 32 | 88742082 | RC0VAF05 D11KF05 D11 65 M14 | 88658097 | AB22 32D 0SET |
| DN 40 - 50 | 88742083 | RC0VAF07 D14KF07 D14 80 M18 | 88658099 | AB22 50D 0SET |
| DN 65 | 88742085 | RC0VAF07 D17KF07 D17100 M22 | 88658101 | AB22 65D 0SET |
| DN 80 | 88742085 | RC0VAF07 D17KF07 D17100 M22 | 88658102 | AB22 80D 0SET |
| DN 100 | 88742085 | RC0VAF07 D17KF07 D17100 M22 | 88658103 | AB22100D 0SET |

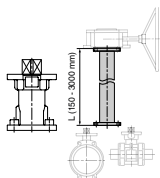

GEMÜ RC0

Shaft extension

The RC0 shaft extension for quarter turn valves is a distance piece between manually, pneumatically or electrically operated valves. This means that valves can be protected from flooding or better access for operation of the valve can be ensured (also for manual override).

Ball valve with shaft neck extension,
K-no. 5227, as well as variants thereof
K-no. 7132, 7138, 5232, 5234, 5235, 5238, 5239

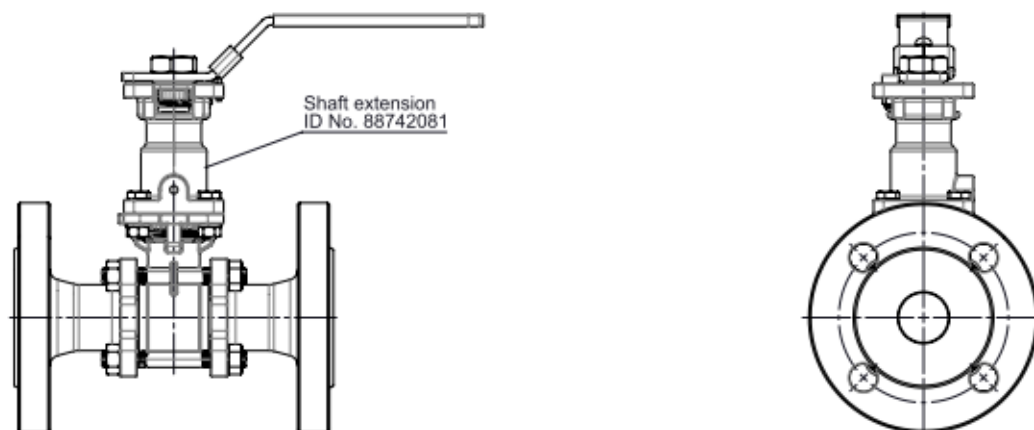

Ordering information for ball valve with RC0 shaft neck extension, for thermal separation (K-no. 5227)

The manual ball valve is equipped with an RC0 shaft neck extension and a hand lever.
The shaft neck height is dependent on the nominal size of the ball valve.

Ordering information for ball valve with RC0 shaft neck extension, for thermal separation, cleaned so that it's PWIS-free (K-no. 7097 - 5227, 0101)

The manual ball valve is equipped with an RC0 shaft neck extension and a hand lever.
The shaft neck height is dependent on the nominal size of the ball valve.
The media wetted area is cleaned without compromising the paint coating.

Ordering information for ball valve with RC0 shaft neck extension, for thermal separation, cleaned so that it's PWIS-free (K-no. 7039 - 5227, 0107)

The manual ball valve is equipped with an RC0 shaft neck extension and a hand lever.
The shaft neck height is dependent on the nominal size of the ball valve.
The media wetted area is degreased.

Mounting example

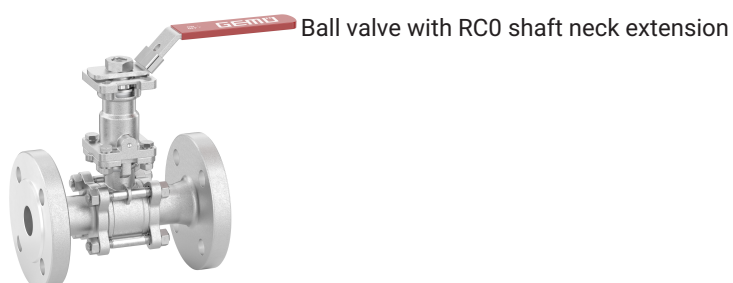

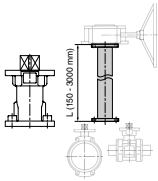

GEMÜ RC0

Shaft extension

The RC0 shaft extension for quarter turn valves is a distance piece between manually, pneumatically or electrically operated valves. This means that valves can be protected from flooding or better access for operation of the valve can be ensured (also for manual override).

Preparation for mounting a position indicator (K-no. 5237 - 5227, 7056)

NOTE: The corresponding mounting kit must be entered separately.

Ordering information for ball valve with RC0 shaft neck extension, prepared for mounting a position indicator (K-no. 5237 - 5227, 7056)

The manual ball valve is equipped with an RC0 shaft neck extension and a modified hand lever. Different limit switches can then be mounted. These must be ordered separately. See GEMÜ LSF or LSC for this.

Ordering information for ball valve with RC0 shaft neck extension, prepared for mounting a position indicator (K-no. 5240 - 5227, 0101, 7056)

The manual ball valve is equipped with an RC0 shaft neck extension and a modified hand lever. The media wetted area is cleaned without compromising the paint coating. Different limit switches can then be mounted. These must be ordered separately. See GEMÜ LSF or LSC for this.

Ordering information for ball valve with RC0 shaft neck extension, prepared for mounting a position indicator (K-no. 5241 - 5227, 0107, 7056)

The manual ball valve is equipped with an RC0 shaft neck extension and a modified hand lever. The media wetted area is degreased. Different limit switches can then be mounted. These must be ordered separately. See GEMÜ LSF or LSC for this.

Mounting example

Ball valve with RC0 shaft neck extension

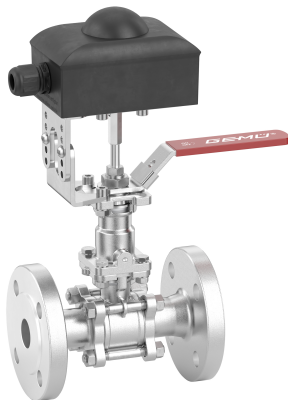

GEMÜ MSC

Mounting kit

The MSC mounting kit is an interface, for the same and different ends, to join flange designs according to ISO 5211. This mounting kit ensures thermal separation of actuator and valve body. It can also be used as height compensation for insulated pipelines. The mounting kit is available in steel, electrogalvanized and stainless steel in an open or closed design.

GEMÜ ADH**Mounting sleeve**

The mounting sleeve accessories are available in the square and star geometry designs. These are used for the shaft and hub support for quarter turn actuators. Both sleeves have an internal square drive (please observe stated measurement dimensions here). The sleeve material is sintered metal and they are chemically nickel plated with a surface of 25 µm.

Certificates

| Certificate | Standard | Item number |
|--------------|----------|-------------|
| 3.1 Material | EN 10204 | 88333336 |

GEMÜ CONEXO

The interaction of valve components that are equipped with RFID chips and an associated IT infrastructure actively increase process reliability.



Thanks to serialization, every valve and every relevant valve component such as the body, actuator or diaphragm, and even automation components, can be clearly traced and read using the CONEXO pen RFID reader. The CONEXO app, which can be installed on mobile devices, not only facilitates and improves the "installation qualification" process, but also makes the maintenance process much more transparent and easier to document. The app actively guides the maintenance technician through the maintenance schedule and directly provides him with all the information assigned to the valve, such as test reports, testing documentation and maintenance histories. The CONEXO portal acts as a central element, helping to collect, manage and process all data.

For further information on GEMÜ CONEXO please visit:

www.gemu-group.com/conexo

Ordering

GEMÜ Conexo must be ordered separately with the ordering option "CONEXO".

Installing the RFID chip

In the corresponding design with CONEXO, this product has an RFID chip for electronic identification purposes. The position of the RFID chip can be seen below.

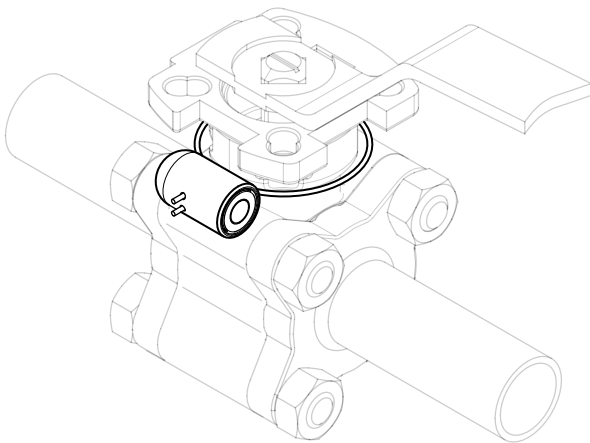



GEMÜ Gebr. Müller Apparatebau GmbH & Co. KG
Fritz-Müller-Straße 6-8, 74653 Ingelfingen-Criesbach, Germany
Phone +49 (0) 7940 1230 · info@gemu.de
www.gemu-group.com