

Construction

The GEMÜ C30 is equipped with a PFA transmitter and a pressure gauge. The body is made from PFA/PTFE and can be directly integrated into the pipe system by common flare unions. A PFA double diaphragm prevents contamination of the working medium. Only the PFA/PTFE body and the PFA diaphragm are wetted parts. The pressure is transmitted by a monitor liquid (IPA (isopropyl alcohol) / DI water, further liquids on request). The pressure gauge complies with EN 837-1.

Features

- C30 is especially suitable for pressure measurement of ultra high purity chemicals
- All wetted parts are made from High Purity PFA/PTFE
- Pressure transmission by double diaphragm technology
- Pressure gauge can be rotated through 360°
- Not suitable for applications with strong vibrations, pulsing process pressure or pressure peaks; provide for suitable pulsation dampers and throttling sections, if necessary
- Optionally with electrical switching contacts
- REACH / RoHS compliant
- Other certificates on request (e.g. FDA compliance)

Advantages

- Minimal deadleg
- The proven GEMÜ **CleanStar®** technology is the basis of the transmitter
- Working medium hermetically isolated from the gauge by a double diaphragm
- Proven long term reliability
- Pressure gauge can be positioned through 360° enabling individual user options
- Production, assembly, calibration and packaging in cleanroom ISO 6

Dimensions - GEMÜ C30

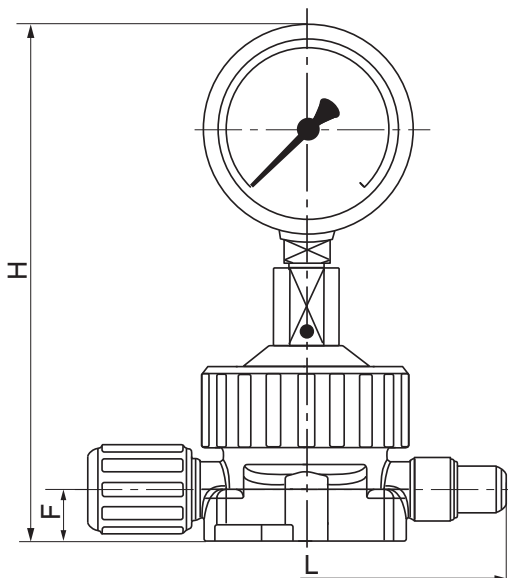
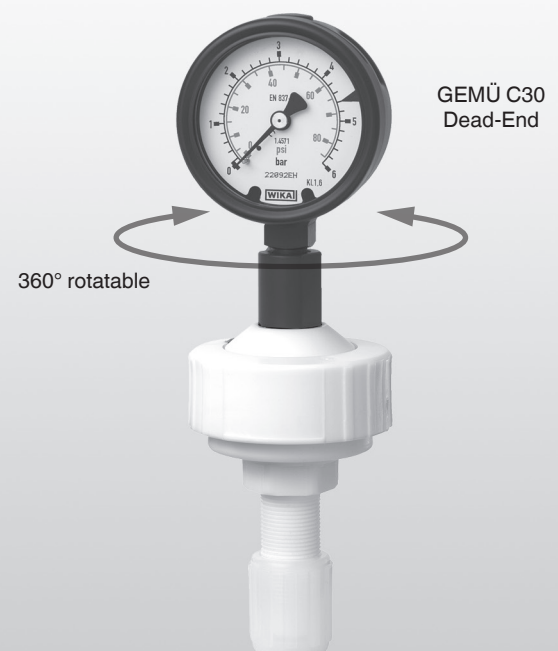
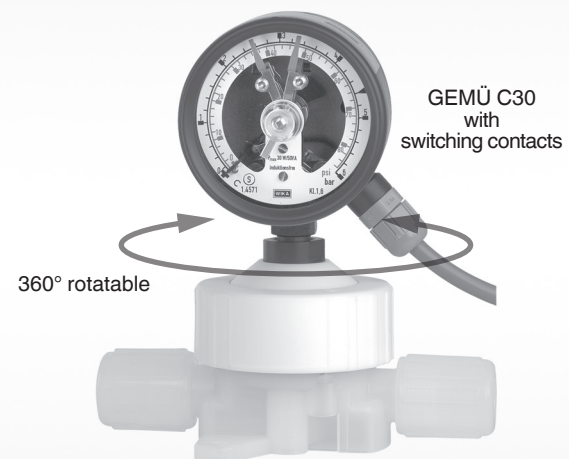

Table of dimensions and further dimensions see last page.



Technical data

Transmitter

Flow medium

Suitable for any inert or corrosive gases or liquids, especially high purity media which do not corrode the respective body and diaphragm materials.

Version of transmitter diaphragm

- Double diaphragm system for working-/ measuring range ≥ 0 bar relative (Code BF, BG, BH)
- Single diaphragm for working-/ measuring range ≤ 0 bar relative (Code CF, CG, CH)

Material of wetted parts

Diaphragm PFA
Body PFA (In-Line), PTFE (Dead-End)

Flow direction

Optional

Working range

Constant: 3/4 of full scale range
Variable: 2/3 of full scale range
Momentary: full scale range

Temperature

Ambient 41 ... 140 °F
Medium 41 ... 140 °F
Storage/transport -4 ... 140 °F
Depending on operating pressure

Influence of temperature

0.5 % of measuring range (scale end value) per 10°C temperature change (reference temperature 20°C).

Pressure/temperature correlation

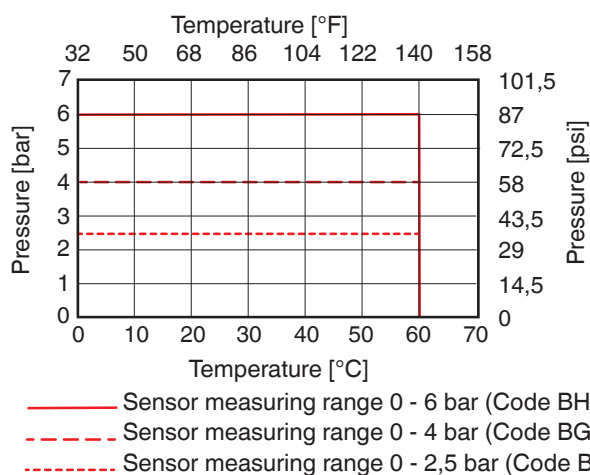

Pressure gauge

Accuracy

± 1.6 % of measuring range or scale end value

Nominal size

063 mm

Material of measuring system

CrNi steel 1.4571

Gauge material

CrNi steel with Teflon coating

Switching contacts (optionally)

Switching functions

Make contact: closes as pressure increases
Break contact: opens as pressure decreases
The switching function is irrelevant when piloting a PLC.

Inductive contact

Non-touching switch, no wear, high reliability, additional switching unit required

Magnetic spring contact

Open contacts, can switch power directly

Electronic contact

Inductive contact with integrated switching amplifier, non-touching switch, high reliability, for direct connection to a PLC or piloting relays

Limiting values for the contact load at ohmic load

Rated voltage U_{eff}	Inductive contact type 81		Magnetic spring contact type 82	
	unfilled units		filled units	
Rated working current:	250 V			
Start-up current	0.7 A	1.0 A	1.0 A	1.0 A
Cutoff current	0.7 A	1.0 A	1.0 A	1.0 A
Constant current	0.6 A	0.6 A	0.6 A	0.6 A
Switch rating	10 W/18 VA	30 W/50 VA	20 W/20 VA	

Order data

Transmitter

Nominal size		Code
1/4" (only Dead-End)	DN 4	4
3/8" (Dead-End + In-Line)	DN 6	6
1/2" (Dead-End + In-Line)	DN 10	8
3/4" (only In-Line)	DN 15	12
1" (only In-Line)	DN 20	16
1 1/4" (only In-Line)	DN 25	20

Mounting variant	Code
Dead-End	E
In-Line	L

Connection	Code
NPT male thread (only 1/4" Dead-End)	13
Flare connection with CPFA union nut	73
Flare connection with PVDF union nut	75
Flare connection with PFA union nut	77

Body material	Code
PTFE (Dead-End)	26
PFA (In-Line)	30

Diaphragm material	Code
PFA	H3

Measuring range*			Code
0...30 psi	0...250 kPa	0...2.5 bar**	BF
0...60 psi	0...400 kPa	0...4.0 bar	BG
0...100 psi	0...600 kPa	0...6.0 bar	BH
-30 inHg...15 psi	-100...150 kPa	-1...1.5 bar**	CF
-30 inHg...30 psi	-100...300 kPa	-1...3.0 bar	CG
-30 inHg...60 psi	-100...500 kPa	-1...5.0 bar	CH

* Pressure reference: Relative pressure
** Not possible with electrical contacts

Connection form	Code
Back, center mount, not possible with switching contacts	B
Bottom	U

Sight glass	Code
Acrylic glass	A

Switching contacts		Code
Without		Z
Inductive contact	1. Break / 2. Make contact	I
Inductive contact	1. Make / 2. Break contact	K
Magnetic spring contact	1. Break / 2. Make contact	M
Magnetic spring contact	1. Make / 2. Break contact	N
Electronic contact PNP	1. Break / 2. Make contact	P
Electronic contact PNP	1. Make / 2. Break contact	S

Pressure gauge

Units	Code
Double scale bar / psi	B
Double scale psi / bar	D
Double scale kPa / bar	G

Fill fluid of transmitter	Code
Isopropyl-alcohol (IPA) / DI-water 50:50	2
further fill fluids on request	

Transmitter version	Code
High Purity White	HPW

Order example	C30	8	L	75	30	H3	B	BF	U	A	Z	2	HPW
Type	C30												
Nominal size (code)		8											
Mounting variant (code)			L										
Connection (code)				75									
Body material (code)					30								
Diaphragm material (code)						H3							
Unit (code)							B						
Measuring range (code)								BF					
Connection form (code)									U				
Sight glass (code)										A			
Switching contacts (code)											Z		
Fill fluid of transmitter (code)												2	
Transmitter version (code)													HPW

**Dimensions - GEMÜ C30 Normal version,
with switching contacts and Dead-End version [mm / inch]**

In-Line

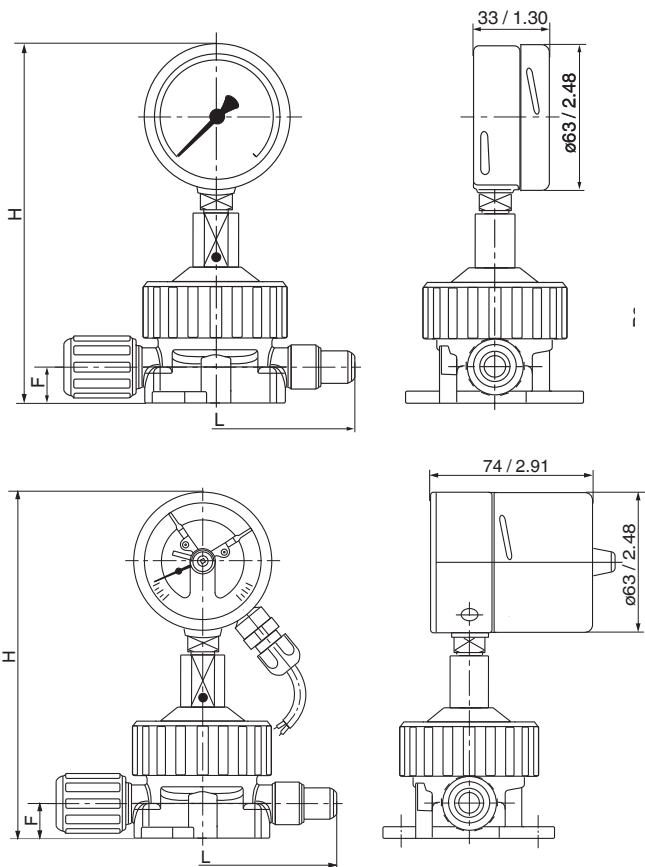

for version with Min./Max. contact

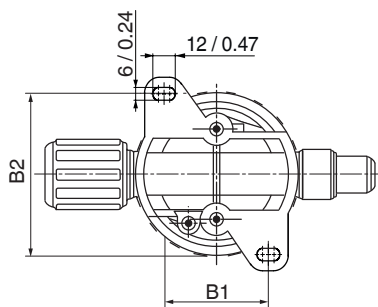

Dead-End

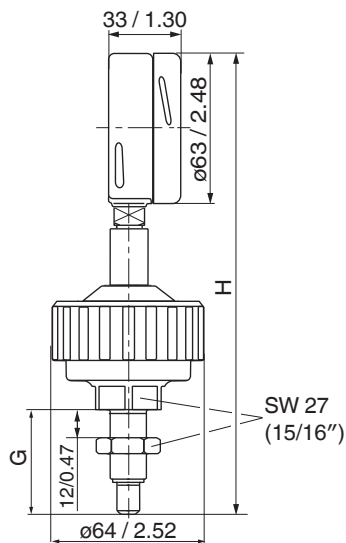

	[mm]		[inch]	
	H	G	H	G
1/4" Flare	193.0	44.0	7.60	1.73
3/8" Flare	193.0	44.0	7.60	1.73
1/2" Flare	196.0	47.0	7.72	1.85

	[mm]					[inch]				
	H	L	F	B1	B2	H	L	F	B1	B2
3/8" Flare	156.0	118	16	40	62	6.14	4.65	0.63	1.57	2.44
1/2" Flare	156.0	122	16	40	62	6.14	4.80	0.63	1.57	2.44
3/4" Flare	162.0	122	19	40	62	6.38	4.80	0.75	1.57	2.44
1" Flare	186.5	165	25	56	78	7.34	6.50	0.98	2.20	3.07
1 1/4" Flare	186.5	224	25	56	78	7.34	8.82	0.98	2.20	3.07

For further High purity products, accessories and other products, please see our
Product Range catalogue and Price List. Contact GEMÜ.

GEMÜ® VALVES, MEASUREMENT
AND CONTROL SYSTEMS

