

GEMÜ Code 29 EPDM diaphragm



Features

- Fabric-reinforced
- Geringe Drehmomente
- High performance capability thanks to improved positioning of the fabric insert
- Greatly reduced adhesive behaviour (no adhesion on the valve seat) of the diaphragm as a result of new material compounding
- Extremely long service life thanks to good material properties
- Simple and defined mounting thanks to the threaded pin that is vulcanised in place with integrated screw-in stop

Description

The GEMÜ code 29 diaphragm is a one-piece peroxide-cured EPDM diaphragm that has been developed for use in industrial applications. The diaphragm displays reduced setting behaviour and signs of wear, which enables high switching cycles and therefore an increased service life. The GEMÜ code 29 EPDM diaphragm is suitable for use with abrasive media. The diaphragm is specifically compounded for GEMÜ and manufactured within the GEMÜ Group.

Technical specifications

- **Media temperature:** 14 to 212 °F
- **Sterilization temperature:** Not sterilizable
- **Diaphragm material:** EPDM
- **Diaphragm sizes:** 10 | 20 | 25 | 40 | 50 | 65 | 80 | 100 | 125 | 150 | 200
- **Vacuum:** up to 70 mbar (absolute)

Technical data depends on the respective configuration

Product comparison



	GEMÜ Code 29	GEMÜ Code 4A/4	GEMÜ Code 2	GEMÜ Code 6	GEMÜ Code 8
Media temperature	-10 to 100 °C	-10 to 90 °C	-10 to 100 °C	-5 to 100 °C	-10 to 100 °C
Diaphragm materials					
CR	-	-	-	-	●
EPDM	●	-	-	-	-
FKM	-	●	-	-	-
IIR	-	-	-	●	-
NBR	-	-	●	-	-
Diaphragm sizes					
8	-	●	-	-	-
10	●	●	●	-	-
20	●	●	●	-	-
25	●	●	●	●	●
40	●	●	●	●	●
50	●	●	●	●	●
65	●	●	●	●	●
80	●	●	●	●	●
100	●	●	●	●	●
125	●	●	●	●	-
150	●	●	●	●	-
200	●	-	-	●	-
Conformities					
BSE/TSE	●	-	●	●	●

Each application must be analysed before the selection of the diaphragm material. Since the most varied operating conditions often prevail within a plant at different locations, it can be necessary to use different valves and materials. In particular, the chemical properties and the temperature of the working media often lead to different interactions. The suitability of the materials used must therefore always be examined individually with regard to the current resistance list or checked by an authorised specialist. Only this procedure guarantees that the application will operate safely and economically for a longer period. Diaphragms are wearing parts. They need to be regularly inspected and replaced otherwise malfunctions can occur, possibly resulting in hazardous situations.

Please note: The maintenance intervals for inspecting and replacing diaphragms are application-dependent. In order to determine a suitable maintenance interval, the maintenance history and the stresses placed on the parts due to frequent cycle duties must be taken into account.

Product comparison



	GEMÜ Code 5T	GEMÜ Code 56	GEMÜ Code 71
Media temperature	-10 to 100 °C	-10 to 100 °C	-20 to 100 °C
Diaphragm materials			
PTFE/FKM	●	●	-
PTFE/PVDF/EPDM	-	-	●
Diaphragm sizes			
10	●	●	●
20	-	●	-
25	●	●	●
40	●	●	●
50	●	●	●
80	●	●	●
100	●	●	●
Conformities			
BSE/TSE	●	●	●

Each application must be analysed before the selection of the diaphragm material. Since the most varied operating conditions often prevail within a plant at different locations, it can be necessary to use different valves and materials. In particular, the chemical properties and the temperature of the working media often lead to different interactions. The suitability of the materials used must therefore always be examined individually with regard to the current resistance list or checked by an authorised specialist. Only this procedure guarantees that the application will operate safely and economically for a longer period. Diaphragms are wearing parts. They need to be regularly inspected and replaced otherwise malfunctions can occur, possibly resulting in hazardous situations.

Please note: The maintenance intervals for inspecting and replacing diaphragms are application-dependent. In order to determine a suitable maintenance interval, the maintenance history and the stresses placed on the parts due to frequent cycle duties must be taken into account.

Product description

Construction

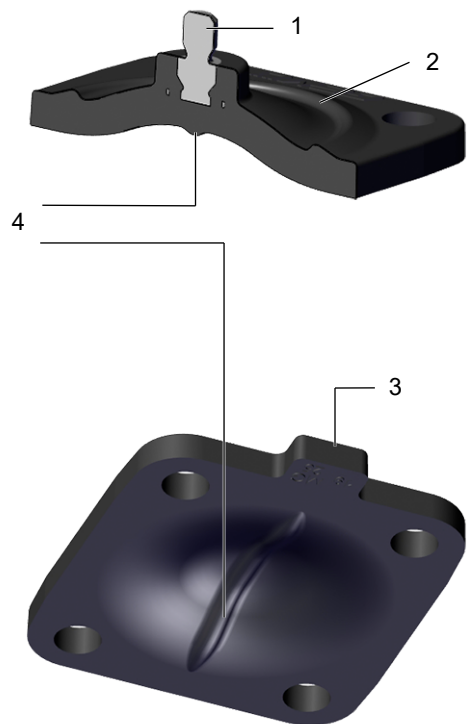

Item	Name
1	Threaded pin vulcanized in place with integrated screw-in stop
2	Additional sealing bead for optimum external sealing
3	Tab
4	Sealing bead for reliable sealing on the valve weir

GEMÜ CONEXO

The interaction of valve components that are equipped with RFID chips and an associated IT infrastructure actively increase process reliability.



Thanks to serialization, every valve and every relevant valve component such as the body, actuator or diaphragm, and even automation components, can be clearly traced and read using the CONEXO pen RFID reader. The CONEXO app, which can be installed on mobile devices, not only facilitates and improves the "installation qualification" process, but also makes the maintenance process much more transparent and easier to document. The app actively guides the maintenance technician through the maintenance schedule and directly provides him with all the information assigned to the valve, such as test reports, testing documentation and maintenance histories. The CONEXO portal acts as a central element, helping to collect, manage and process all data.

For further information on GEMÜ CONEXO please visit:

www.gemu-group.com/conexo

Ordering

GEMÜ Conexo must be ordered separately with the ordering option "CONEXO".

For electronic identification purposes, each replaceable component contained in the product you have purchased is equipped with an RFID chip (1). Where you can find the RFID chip differs from product to product.

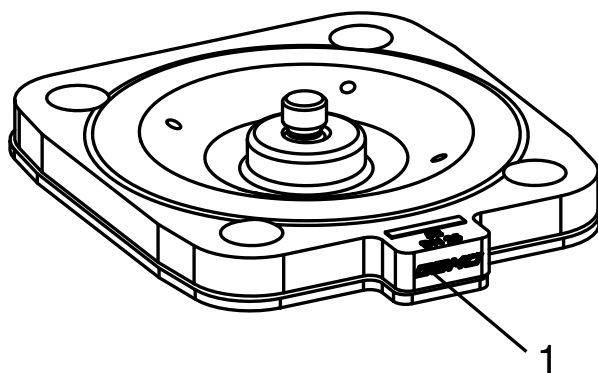

Fig. 1: Diaphragm RFID chip

Order data

The order data provide an overview of standard configurations.

Please check the availability before ordering. Other configurations available on request.

Order codes

1 Type	Code
Diaphragm size 10 to 100, without diaphragm size 20 and 65	
Diaphragm	600
Diaphragm size 20	
Diaphragm	R690
Diaphragm size 65, diaphragm size 125 to 200	
Diaphragm	620

2 Diaphragm size	Code
Diaphragm size 10	10
Diaphragm size 20	20
Diaphragm size 25	25
Diaphragm size 40	40
Diaphragm size 50	50
Diaphragm size 65	65
Diaphragm size 80	80
Diaphragm size 100	100
Diaphragm size 125	125
Diaphragm size 150	150
Diaphragm size 200	200

3 Replacement diaphragm	Code
Replacement diaphragm	M

4 Diaphragm material	Code
EPDM	29

5 Packaging unit	Code
Without	

6 Type of design	Code
Without	
Media wetted area cleaned to ensure suitability for paint applications, parts sealed in plastic bag	0101
Media wetted parts cleaned for high purity media and packed in plastic bag	0104

7 Special version	Code
Without	

8 CONEXO	Code
Without	
Integrated RFID chip for electronic identification and traceability	C

Order example

Order option	Code	Description
1 Type	600	Diaphragm
2 Diaphragm size	10	Diaphragm size 10
3 Replacement diaphragm	M	Replacement diaphragm
4 Diaphragm material	29	EPDM
5 Packaging unit		Without
6 Type of design		Without
7 Special version		Without
8 CONEXO		Without

Technical data

Medium

Working medium: Corrosive, inert, gaseous and liquid media which have no negative impact on the physical and chemical properties of the body and diaphragm material.

Temperature

Media temperature: 14 – 212 °F

Storage temperature: 14 °C – 77 °F (preferably 59 °F) must be observed

Pressure

Operating pressure: max. 150 psi (dependent on the diaphragm valve used)

Vacuum: Can be used up to a vacuum of 2.1 inhg (absolute)

Product conformities

BSE/TSE: The product conforms to EMA/410/01 revision 3 and is free of animal substances

Unused components: Certificate BAM / ZBA / 005 / 07
ACS
PVC

Mechanical data

Service life: Max. recommended service life, 8 years
The service life is the sum of the storage life and operating life.
Note the Technical Information "Service life, storage and marking of GEMÜ diaphragms".

Dimensions

EPDM diaphragm

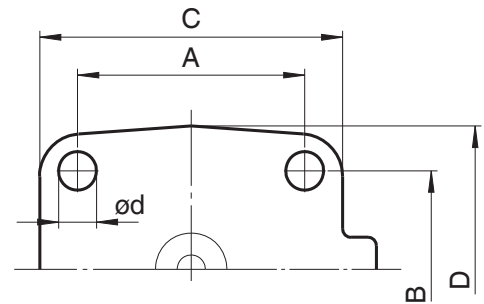

MG 10 to 80

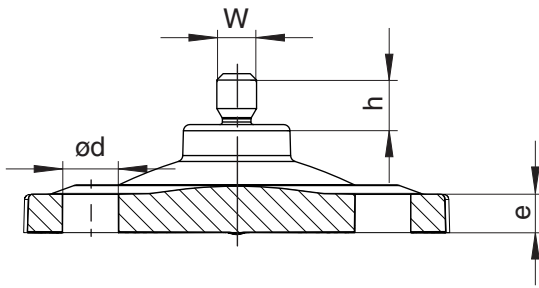

MG 10 to 200

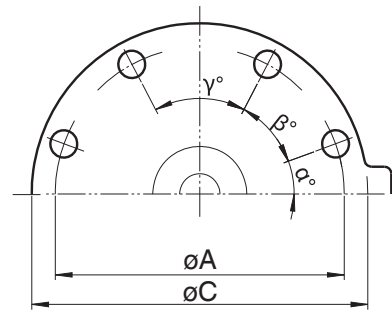

MG 100 to 200

MG	DN	NPS	A	B	C	D	$\varnothing d$	e	h	W	α	β	γ	n
10	10 - 20	3/8" - 3/4"	1.54	1.73	1.89	2.09	0.20	0.20	0.35	M4	-	-	-	4
20	15 - 25	1/2", 3/4", 1"	1.75	1.57	2.42	2.24	0.25	0.20	0.35	5/32"	-	-	-	4
25	15 - 25	1/2" - 1"	2.13	1.81	2.83	2.64	0.35	0.24	0.31	1/4"	-	-	-	4
40	32 - 40	1 1/4" - 1 1/2"	2.76	2.56	3.94	3.54	0.45	0.28	0.31	1/4"	-	-	-	4
50	50	2"	3.23	3.07	4.88	4.17	0.51	0.28	0.28	1/4"	-	-	-	4
80	80	3"	5.00	4.49	7.32	6.14	0.71	0.28	0.31	5/16"	-	-	-	4
100	100	4"	7.72	-	9.06	-	0.51	0.39	0.35	5/16"	28.0°	42.0°	40.0°	8
125	125	5"	8.74	-	10.24	-	0.69	0.45	0.44	3/8"	25.0°	43.5°	43.5°	8
150	150	6"	10.71	-	12.05	-	0.69	0.47	0.44	3/8"	20.0°	35.0°	35.0°	10
200	200	8"	14.72	-	16.14	-	0.67	0.52	0.55	7/8"	18.0°	27.0°	22.5°	14

Dimensions in inch

n = number of bolts

The thread of the diaphragm pin "W" corresponds to Whitworth standard.



GEMÜ Gebr. Müller Apparatebau GmbH & Co. KG
Fritz-Müller-Straße 6-8, 74653 Ingelfingen-Criesbach, Germany
Tel. +49 (0)7940 123-0 · info@gemue.de
www.gemu-group.com