

GEMÜ Code 5T PTFE/FKM diaphragm



Features

- Fabric reinforced FKM backing (diaphragm size 10 to diaphragm size 100)
- Resistant to aggressive chemicals such as hydrocarbons (aromatic, non-aromatic and chlorinated), mineral acids and chlorine bleach
- Ozone and weather resistant
- Very high chemical resistance due to PTFE face
- Simple and defined mounting thanks to the threaded pin that is vulcanised in place with integrated screw-in stop
- Improved service life
- Improved long-term tightness thanks to optimized geometry
- Improved vacuum compatibility
- Easy-to-read identification

Description

The GEMÜ PTFE / FKM diaphragm code 5T has a two-piece design and consists of a PTFE face and a FKM backing. The diaphragm is available in diaphragm sizes 10 to 100 and has a threaded pin that is sintered into place with integrated screw-in stop. The diaphragm has been developed for use in industrial applications, for example in the chemical industry, environmental engineering or the processing industry.

Technical specifications

- **Media temperature :** -10 to 100 °C
- **Diaphragm material:** PTFE/FKM
- **Diaphragm sizes:** 10 | 25 | 40 | 50 | 80 | 100

Technical data depends on the respective configuration

Product comparison



	GEMÜ Code 29	GEMÜ Code 4A/4	GEMÜ Code 2	GEMÜ Code 6	GEMÜ Code 8
Media temperature	-10 to 100 °C	-10 to 90 °C	-10 to 100 °C	-5 to 100 °C	-10 to 100 °C
Diaphragm materials					
CR	-	-	-	-	●
EPDM	●	-	-	-	-
FKM	-	●	-	-	-
IIR	-	-	-	●	-
NBR	-	-	●	-	-
Diaphragm sizes					
8	-	●	-	-	-
10	●	●	●	-	-
20	●	●	●	-	-
25	●	●	●	●	●
40	●	●	●	●	●
50	●	●	●	●	●
65	●	●	●	●	●
80	●	●	●	●	●
100	●	●	●	●	●
125	●	●	●	●	-
150	●	●	●	●	-
200	●	-	-	●	-
Conformities					
BSE/TSE	●	-	●	●	●

Each application must be analysed before the selection of the diaphragm material. Since the most varied operating conditions often prevail within a plant at different locations, it can be necessary to use different valves and materials. In particular, the chemical properties and the temperature of the working media often lead to different interactions. The suitability of the materials used must therefore always be examined individually with regard to the current resistance list or checked by an authorised specialist. Only this procedure guarantees that the application will operate safely and economically for a longer period.

Diaphragms are wearing parts. They need to be regularly inspected and replaced otherwise malfunctions can occur, possibly resulting in hazardous situations.

Please note: The maintenance intervals for inspecting and replacing diaphragms are application-dependent. In order to determine a suitable maintenance interval, the maintenance history and the stresses placed on the parts due to frequent cycle duties must be taken into account.

Product comparison



	GEMÜ Code 5T	GEMÜ Code 56	GEMÜ Code 71
Media temperature	-10 to 100 °C	-10 to 100 °C	-20 to 100 °C
Diaphragm materials			
PTFE/FKM	●	●	-
PTFE/PVDF/EPDM	-	-	●
Diaphragm sizes			
10	●	●	●
20	-	●	-
25	●	●	●
40	●	●	●
50	●	●	●
80	●	●	●
100	●	●	●
Conformities			
BSE/TSE	●	●	●

Each application must be analysed before the selection of the diaphragm material. Since the most varied operating conditions often prevail within a plant at different locations, it can be necessary to use different valves and materials. In particular, the chemical properties and the temperature of the working media often lead to different interactions. The suitability of the materials used must therefore always be examined individually with regard to the current resistance list or checked by an authorised specialist. Only this procedure guarantees that the application will operate safely and economically for a longer period. Diaphragms are wearing parts. They need to be regularly inspected and replaced otherwise malfunctions can occur, possibly resulting in hazardous situations.

Please note: The maintenance intervals for inspecting and replacing diaphragms are application-dependent. In order to determine a suitable maintenance interval, the maintenance history and the stresses placed on the parts due to frequent cycle duties must be taken into account.

Product description



Item	Name
1	Threaded pin sintered in place with integrated screw-in stop
2	Sealing bead for optimum external sealing
3	Tab
4	PTFE face
5	Sealing bead for reliable sealing on the valve weir
6	FKM backing

Order data

The order data provide an overview of standard configurations.

Please check the availability before ordering. Other configurations available on request.

Order codes

1 Type	Code
Diaphragm	600

2 Diaphragm size	Code
Diaphragm size 10	10
Diaphragm size 25	25
Diaphragm size 40	40
Diaphragm size 50	50
Diaphragm size 80	80
Diaphragm size 100	100

3 Replacement diaphragm	Code
Replacement diaphragm	M

4 Diaphragm material	Code
Backing diaphragm PTFE/FKM for diaphragm code 5T	5T

5 Type of design	Code
Without	
Media wetted area cleaned to ensure suitability for paint applications, parts sealed in plastic bag	0101
Media wetted parts cleaned for high purity media and packed in plastic bag	0104

6 CONEXO	Code
Without	

Order example

Ordering option	Code	Description
1 Type	600	Diaphragm
2 Diaphragm size	10	Diaphragm size 10
3 Replacement diaphragm	M	Replacement diaphragm
4 Diaphragm material	5T	Backing diaphragm PTFE/FKM for diaphragm code 5T
5 Type of design		Without
6 CONEXO		Without

Technical data

Medium

Working medium: Corrosive, inert, gaseous and liquid media which have no negative impact on the physical and chemical properties of the body and diaphragm material.

Temperature

Media temperature: -10 – 100 °C

Steam temperature: max. 150 °C¹⁾, max. 180 min.²⁾

¹⁾The steam temperature is only valid for steam (saturated steam) or superheated water.

²⁾If the steam temperatures listed above are applied to the PTFE/FKM diaphragms for longer periods of time, the service life of the diaphragms will be reduced. In these cases, maintenance cycles must be adapted accordingly.

Storage temperature: Storage temperature in accordance with technical information "Service life, storage and marking of GEMÜ diaphragms".

Pressure

Operating pressure: max. 10 bar (dependent on the diaphragm valve used)

Vacuum: Can be used up to a vacuum of 70 mbar (absolute)

Mechanical data

Service life: Max. recommended service life, 10 years

The service life is the sum of the storage life and operating life.

Note the Technical Information "Service life, storage and marking of GEMÜ diaphragms".

Dimensions

FKM backing

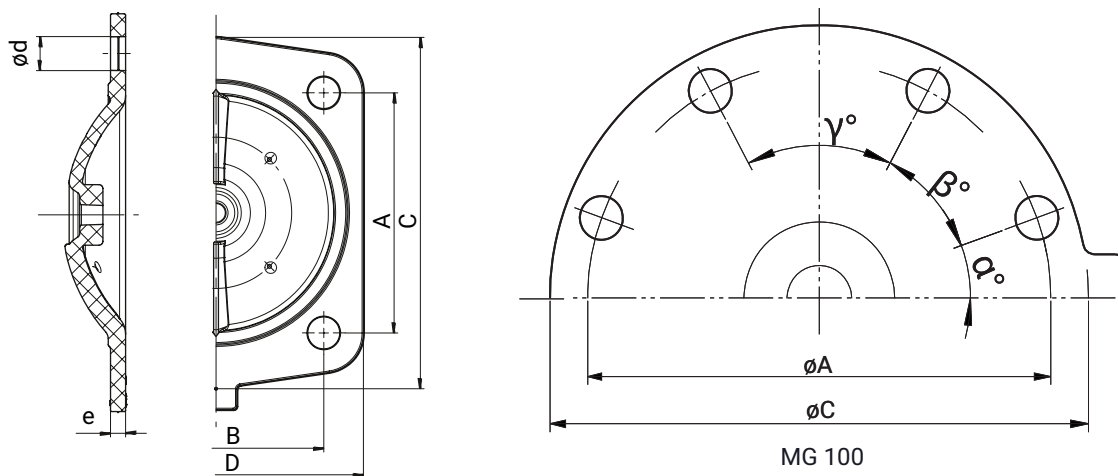

MG	DN	NPS	A	B	C	D	ϕd	e	n
10	10 - 20	3/8" - 3/4"	39.0	44.0	49.0	54.0	5.2	4.0	4
25	15 - 25	1/2" - 1"	54.0	46.0	72.0	67.0	9.0	6.0	4
40	32 - 40	1 1/4" - 1 1/2"	70.0	65.0	100.0	90.0	11.0	6.0	4
50	50	2"	82.0	78.0	124.0	107.0	13.5	6.0	4
80	80	3"	127.0	114.0	186.0	156.0	18.0	8.0	4
100	100	4"	194.0	-	228.0	-	14.3	8.5	8

Dimensions in mm, MG = diaphragm size

The thread of the diaphragm pin "W" corresponds to Whitworth standard.

PTFE face

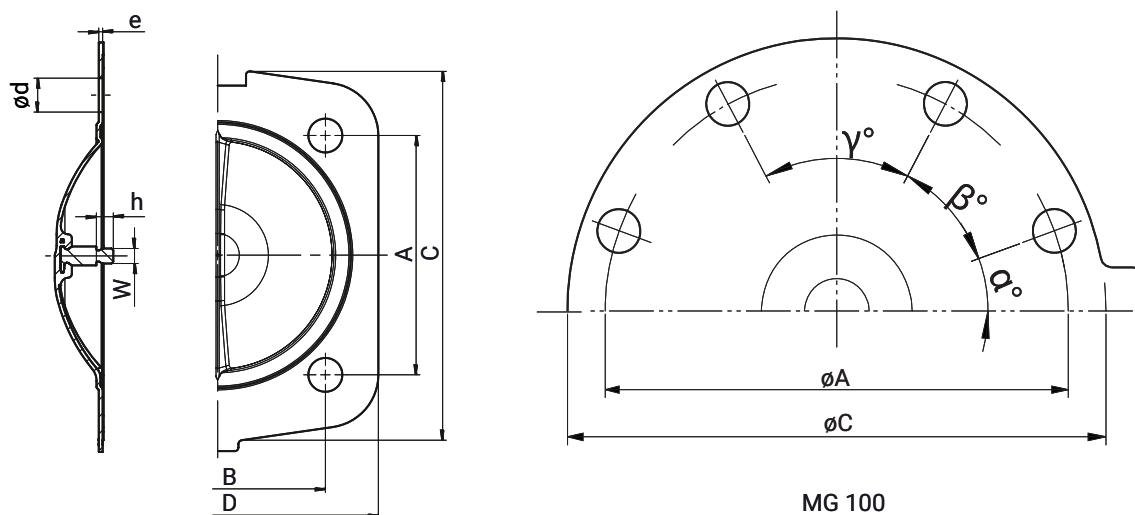

MG 100

MG	DN	NPS	A	B	C	D	ød	e	h	W	n
10	10 - 20	3/8" - 3/4"	40.0	45.1	49.0	54.0	6.7	1.0	9.2	M4	4
25	15 - 25	1/2" - 1"	54.0	46.0	80.0	75.0	9.0	1.5	6.0	1/4"	4
40	32 - 40	1 1/4" - 1 1/2"	70.0	65.0	107.0	99.0	11.0	1.5	7.4	1/4"	4
50	50	2"	82.0	78.0	130.0	116.0	13.5	1.5	7.4	1/4"	4
80	80	3"	127.0	114.0	196.0	170.0	18.0	2.0	9.0	5/16"	4
100	100	4"	194.5	-	241.0	-	2x13, 6x14	2.0	9.4	5/16"	8

Dimensions in mm, MG = diaphragm size
 The thread of the diaphragm pin "W" corresponds to Whitworth standard.



GEMÜ Gebr. Müller Apparatebau GmbH & Co. KG
Fritz-Müller-Straße 6-8, 74653 Ingelfingen-Criesbach, Germany
Phone +49 (0) 7940 1230 · info@gemue.de
www.gemu-group.com