

GEMÜ Code 71

PTFE / PVDF / EPDM diaphragm



Features

- The diaphragm shows excellent permeation properties, as tested and certified by TÜV SÜD
- Excellent resistance to wet chlorine is tested and confirmed by TÜV SÜD
- Resistant against virtually all chemicals, such as volatile acids, oxidizing agents and salts
- Mounting pin made of grade 7 titanium offers tried and tested corrosion resistance against chlorine, bromine and their derivatives
- Mechanical stop integrated into the diaphragm face mounting pin in order to ensure correct installation
- The diaphragm has no leakage holes in the EPDM backing in order to improve the permeation properties
- The design of the diaphragm face is based on the tried and tested contour of the code 5M diaphragm

Description

The GEMÜ diaphragm code 71 is a three-piece diaphragm that has been developed for use in industrial applications. The diaphragm is made up of a PTFE face, a PVDF intermediate layer and an EPDM backing. The diaphragm is based on the tried and tested design and dimensions of the code 5M diaphragm with regard to the PTFE face. The diaphragm shows excellent permeation properties against gases.. The diaphragm is extremely resistant to wet chlorine in particular due to the PVDF intermediate layer and the titanium mounting pin.

Technical specifications

- **Media temperature:** -20 to 100 °C
- **Diaphragm material:** PTFE/PVDF/EPDM
- **Diaphragm sizes:** 10 | 25 | 40 | 50 | 80 | 100
- **Vacuum:** up to 70 mbar (absolute)

Technical data depends on the respective configuration

Product comparison



	GEMÜ Code 29	GEMÜ Code 4A/4	GEMÜ Code 2	GEMÜ Code 6	GEMÜ Code 8
Media temperature	-10 to 100 °C	-10 to 90 °C	-10 to 100 °C	-5 to 100 °C	-10 to 100 °C
Diaphragm materials					
CR	-	-	-	-	●
EPDM	●	-	-	-	-
FKM	-	●	-	-	-
IIR	-	-	-	●	-
NBR	-	-	●	-	-
Diaphragm sizes					
8	-	●	-	-	-
10	●	●	●	-	-
20	●	●	●	-	-
25	●	●	●	●	●
40	●	●	●	●	●
50	●	●	●	●	●
65	●	●	●	●	●
80	●	●	●	●	●
100	●	●	●	●	●
125	●	●	●	●	-
150	●	●	●	●	-
200	●	-	-	●	-
Conformities					
BSE/TSE	●	-	●	●	●

Each application must be analysed before the selection of the diaphragm material. Since the most varied operating conditions often prevail within a plant at different locations, it can be necessary to use different valves and materials. In particular, the chemical properties and the temperature of the working media often lead to different interactions. The suitability of the materials used must therefore always be examined individually with regard to the current resistance list or checked by an authorised specialist. Only this procedure guarantees that the application will operate safely and economically for a longer period. Diaphragms are wearing parts. They need to be regularly inspected and replaced otherwise malfunctions can occur, possibly resulting in hazardous situations.

Please note: The maintenance intervals for inspecting and replacing diaphragms are application-dependent. In order to determine a suitable maintenance interval, the maintenance history and the stresses placed on the parts due to frequent cycle duties must be taken into account.

Product comparison



	GEMÜ Code 5T	GEMÜ Code 56	GEMÜ Code 71
Media temperature	-10 to 100 °C	-10 to 100 °C	-20 to 100 °C
Diaphragm materials			
PTFE/FKM	●	●	-
PTFE/PVDF/EPDM	-	-	●
Diaphragm sizes			
10	●	●	●
20	-	●	-
25	●	●	●
40	●	●	●
50	●	●	●
80	●	●	●
100	●	●	●
Conformities			
BSE/TSE	●	●	●

Each application must be analysed before the selection of the diaphragm material. Since the most varied operating conditions often prevail within a plant at different locations, it can be necessary to use different valves and materials. In particular, the chemical properties and the temperature of the working media often lead to different interactions. The suitability of the materials used must therefore always be examined individually with regard to the current resistance list or checked by an authorised specialist. Only this procedure guarantees that the application will operate safely and economically for a longer period. Diaphragms are wearing parts. They need to be regularly inspected and replaced otherwise malfunctions can occur, possibly resulting in hazardous situations.

Please note: The maintenance intervals for inspecting and replacing diaphragms are application-dependent. In order to determine a suitable maintenance interval, the maintenance history and the stresses placed on the parts due to frequent cycle duties must be taken into account.

Product description

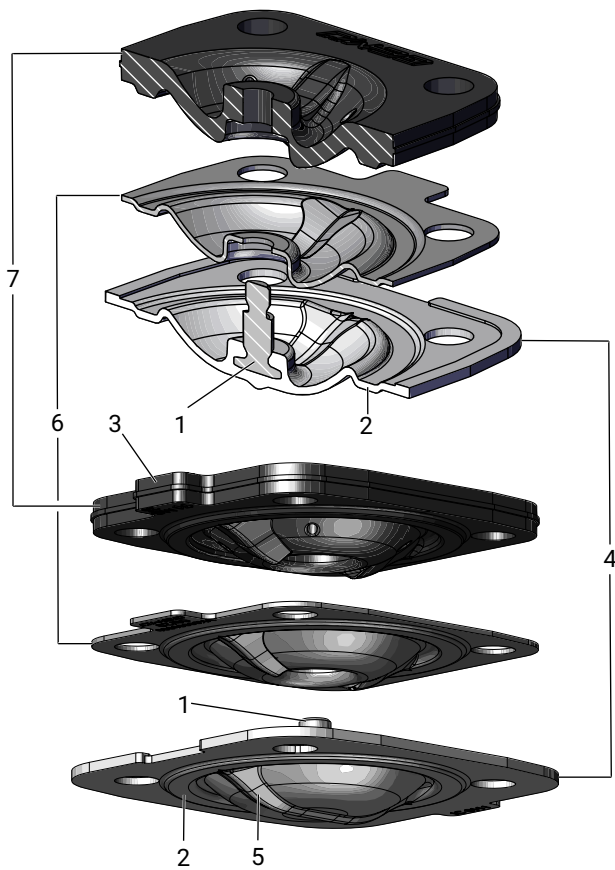

Item	Name
1	Threaded pin sintered in place with integrated screw-in stop
2	Sealing bead for optimum external sealing
3	Tab
4	PTFE face
5	Sealing bead for reliable sealing on the valve weir
6	PVDF intermediate layer
7	EPDM backing

Order data

The order data provide an overview of standard configurations.

Please check the availability before ordering. Other configurations available on request.

Order codes

1 Type	Code
Diaphragm	600

2 Diaphragm size	Code
Diaphragm size 10	10
Diaphragm size 25	25
Diaphragm size 40	40
Diaphragm size 50	50
Diaphragm size 80	80
Diaphragm size 100	100

3 Replacement diaphragm	Code
Replacement diaphragm	M

4 Diaphragm material	Code
PTFE/PVDF/EPDM	71

5 Type of design	Code
Without	
Media wetted area cleaned to ensure suitability for paint applications, parts sealed in plastic bag	0101
Media wetted parts cleaned for high purity media and packed in plastic bag	0104

6 CONEXO	Code
Without	

Order example

Ordering option	Code	Description
1 Type	600	Diaphragm
2 Diaphragm size	10	Diaphragm size 10
3 Replacement diaphragm	M	Replacement diaphragm
4 Diaphragm material	71	PTFE/PVDF/EPDM
5 Type of design		Without
6 CONEXO		Without

Technical data

Medium

Working medium: Corrosive, inert, gaseous and liquid media which have no negative impact on the physical and chemical properties of the body and diaphragm material.

Temperature

Media temperature: -20 – 100 °C

Steam temperature: max. 150 °C¹⁾, max. 180 min.²⁾

¹⁾The steam temperature is only valid for steam (saturated steam) or superheated water.

²⁾If the steam temperatures listed above are applied to the PTFE/PVDF/EPDM diaphragms for longer periods of time, the service life of the diaphragms will be reduced. In these cases, maintenance cycles must be adapted accordingly.

Storage temperature: Storage temperature in accordance with technical information "Service life, storage and marking of GEMÜ diaphragms".

Pressure

Operating pressure: max. 10 bar (dependent on the diaphragm valve used)

Vacuum: Can be used up to a vacuum of 70 mbar (absolute)

Mechanical data

Service life: Max. recommended service life, 8 years

The service life is the sum of the storage life and operating life.

Note the Technical Information "Service life, storage and marking of GEMÜ diaphragms".

Dimensions

EPDM back

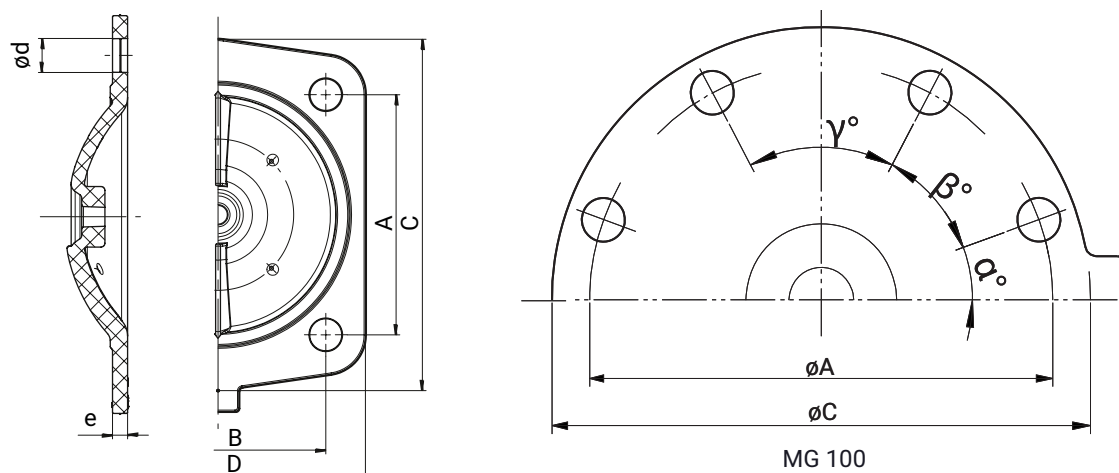

MG	DN	NPS	A	B	C	D	ϕd	e	α	β	γ	n
10	10 - 20	3/8" - 3/4"	39.0	44.0	49.0	54.0	5.2	4.0	-	-	-	4
25	15 - 25	1/2" - 1"	54.0	46.0	72.0	67.0	9.0	6.0	-	-	-	4
40	32 - 40	1 1/4" - 1 1/2"	70.0	65.0	100.0	90.0	11.0	6.0	-	-	-	4
50	50	2"	82.0	78.0	124.0	107.0	13.5	6.0	-	-	-	4
80	80	3"	127.0	114.0	186.0	156.0	18.0	8.0	-	-	-	4
100	100	4"	194.0	-	228.0	-	14.3	8.5	28.0°	42.0°	40.0°	8

Dimensions in mm, MG = diaphragm size

The thread of the diaphragm pin "W" corresponds to Whitworth standard.

Thickness of PVDF intermediate layer 1 mm for each nominal size. The other dimensions can be taken from the EPDM backing table.

PTFE face

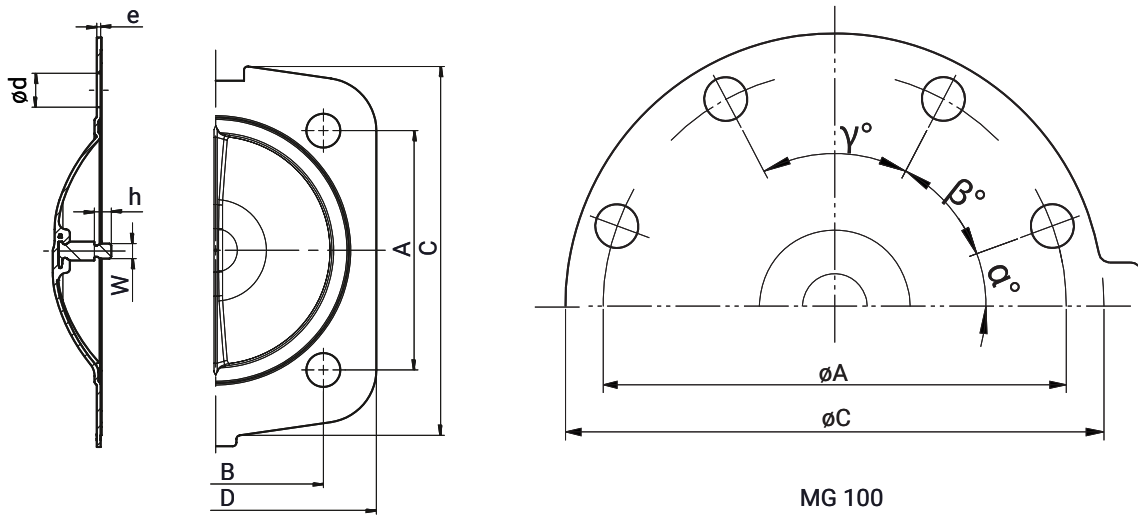

MG	DN	NPS	A	B	C	D	$\varnothing d$	e	h	W	α	β	γ	n
10	10 - 20	3/8" - 3/4"	40.0	45.1	49.0	54.0	6.7	1.0	9.2	M4	-	-	-	4
25	15 - 25	1/2" - 1"	54.0	46.0	80.0	75.0	9.0	1.5	6.0	1/4"	-	-	-	4
40	32 - 40	1 1/4" - 1 1/2"	70.0	65.0	107.0	99.0	11.0	1.5	7.4	1/4"	-	-	-	4
50	50	2"	82.0	78.0	130.0	116.0	13.5	1.5	7.4	1/4"	-	-	-	4
80	80	3"	127.0	114.0	196.0	170.0	18.0	2.0	9.0	5/16"	-	-	-	4
100	100	4"	194.5	-	241.0	-	2x13, 6x14	2.0	9.4	5/16"	28.0°	42.0°	40.0°	8

Dimensions in mm

The thread of the diaphragm pin "W" corresponds to Whitworth standard.



GEMÜ Gebr. Müller Apparatebau GmbH & Co. KG
Fritz-Müller-Straße 6-8, 74653 Ingelfingen-Criesbach, Germany
Phone +49 (0) 7940 1230 · info@gemue.de
www.gemu-group.com