

Pressure retaining valve, Plastic

Construction

The GEMÜ N086 and N186 pressure retaining valves are used to provide a constant back pressure in process plant. If the inlet pressure rises above a preset value, the diaphragm is raised against the spring force. The valve opens and the excess pressure can escape into the outlet line. If the pressure on the inlet side is reduced, the valve closes as the spring force pushes the diaphragm against the seal seat. The spring force can be adjusted as required using a set screw and secured with the lock nut.

Technical specifications*

- Nominal sizes: DN 10 to DN 100
- Connections: Spigots, flanges, union ends with insert
- Body materials: PVC-U, PP-B, PVDF
- Seal materials: EPDM, PTFE
- Media temperature: -20 °C to +100 °C
- Setting range: 0.5 to 10 bar

Advantages

- The working pressure can be very easily adjusted using a set screw and secured with the integrated lock nut. If required, the setting that has been made can be lead sealed.
- The flow-efficient design of the valve body ensures good flow rate values.
- Control errors are kept to a minimum due to the large control face and the spiral spring.
- The actuator is hermetically separated from the medium.

*Dependent on version and/or operating parameters



Sectional view

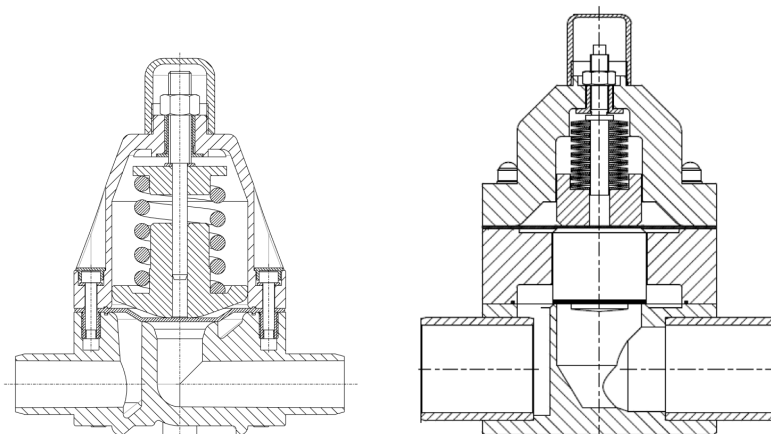

DN 10-80

DN 100

Technical data

Working medium

Corrosive, inert, liquid media which have no negative impact on the physical and chemical properties of the body and seal material. Approved for fluids of Group 1 in accordance with directive 2014/68/EC Article 13 whose steam pressure at the permissible maximum temperature is a maximum of 0.5 bar above the normal atmospheric pressure (1013 mbar).

Working medium temperature

Valve body PVC-U	0 to 60 °C
Valve body PP-B	0 to 80 °C
Valve body PVDF	-20 to 100 °C

The permissible operating pressure depends on the working medium temperature.

Ambient conditions

Ambient temperature	0 to 60 °C
---------------------	------------

Technical data

Type	Nominal size	PN	Setting range [bar]
GEMÜ N186	DN 10 - 50	10	0.5 - 10
GEMÜ N086	DN 65 - 80	6	1 - 6
	DN 100	4	1 - 4

Pressure / temperature correlation for N186 (DN 10 - DN 50)

Temperature in °C (plastic body)		-20	-10	±0	5	10	20	25	30	40	50	60	70	80	90	100
Valve body material		Permissible operating pressure in bar														
PVC-U	Code 1	-	-	-	-	10.0	10.0	10.0	8.0	6.0	3.5	1.5	-	-	-	-
PP-B	Code B5	-	-	10.0	10.0	10.0	10.0	10.0	8.5	7.0	5.5	4.0	2.7	1.5	-	-
PVDF	Code 20	10.0	10.0	10.0	10.0	10.0	10.0	10.0	9.0	8.0	7.0	6.3	5.4	4.7	3.6	2.5

Data for extended temperature ranges on request. Please note that the ambient temperature and medium temperature generate a combined temperature at the valve body which must not exceed the above values.

Pressure / temperature correlation for N086 (DN 65 - DN 80)

Temperature in °C (plastic body)		-20	-10	±0	5	10	20	25	30	40	50	60	70	80	90	100
Valve body material		Permissible operating pressure in bar														
PVC-U	Code 1	-	-	-	-	6.0	6.0	6.0	4.8	3.6	2.10	0.90	-	-	-	-
PP-B	Code B5	-	-	6.0	6.0	6.0	6.0	6.0	5.1	4.2	3.30	2.40	1.62	0.90	-	-
PVDF	Code 20	6.0	6.0	6.0	6.0	6.0	6.0	6.0	5.4	4.8	4.26	3.78	3.24	2.82	2.16	1.50

Data for extended temperature ranges on request. Please note that the ambient temperature and medium temperature generate a combined temperature at the valve body which must not exceed the above values.

Pressure / temperature correlation for N086 (DN 100)

Temperature in °C (plastic body)		-20	-10	±0	5	10	20	25	30	40	50	60	70	80	90	100
Valve body material		Permissible operating pressure in bar														
PVC-U	Code 1	-	-	-	-	4.0	4.0	4.0	3.2	2.4	1.40	0.60	-	-	-	-
PP-B	Code B5	-	-	4.0	4.0	4.0	4.0	4.0	3.4	2.8	2.20	1.60	1.08	0.60	-	-
PVDF	Code 20	4.0	4.0	4.0	4.0	4.0	4.0	4.0	3.6	3.2	2.84	2.52	2.16	1.88	1.44	1.0

Data for extended temperature ranges on request. Please note that the ambient temperature and medium temperature generate a combined temperature at the valve body which must not exceed the above values.

Diagrams - N186

DN 10 - 15

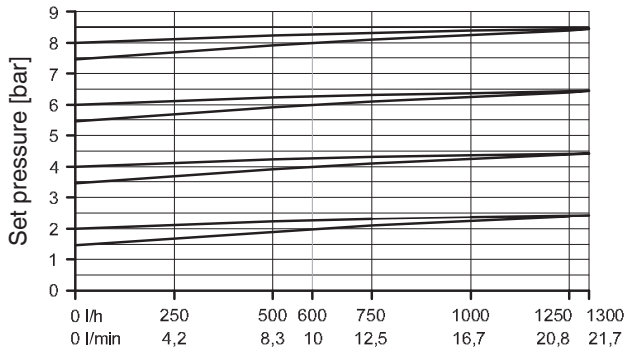

DN 20

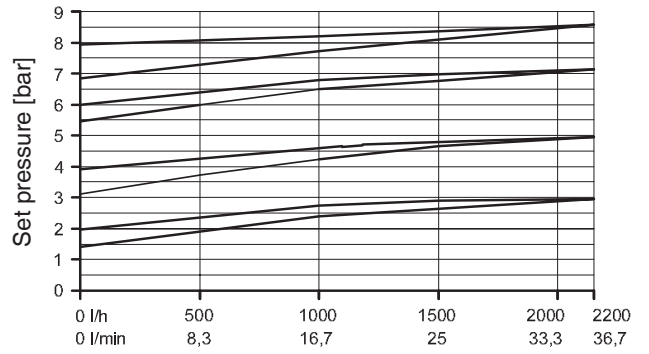

DN 25

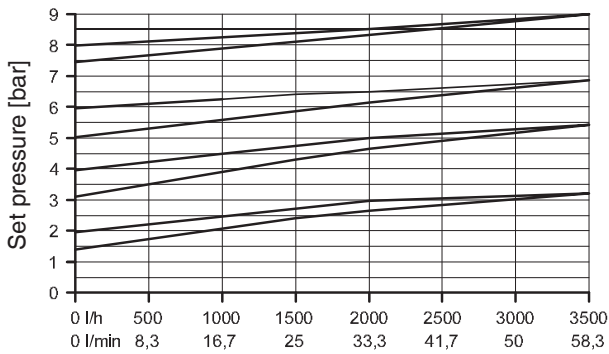

DN 32

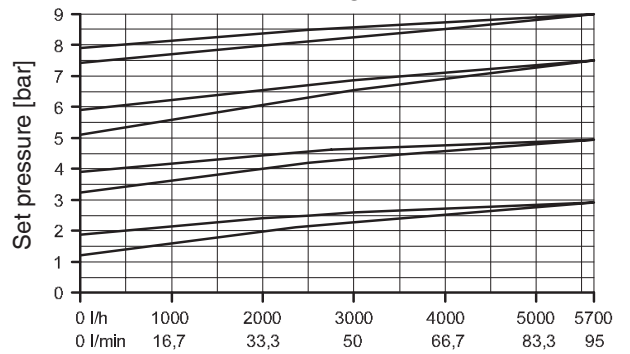

DN 40

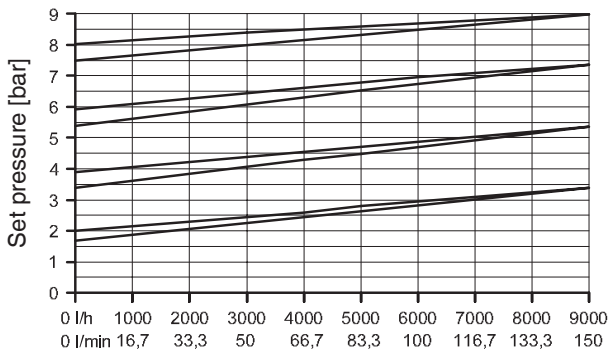

DN 50

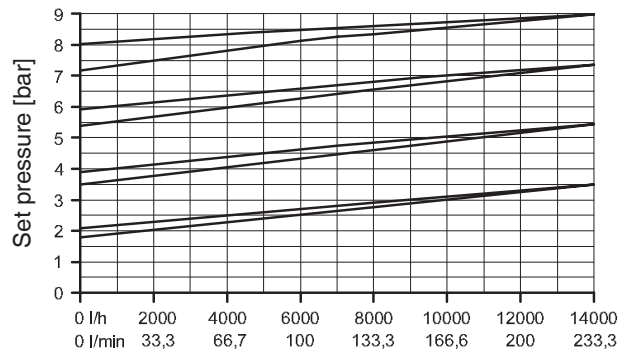

The characteristics in the diagrams show the pressure drop of the set pressure from 0 to max. permissible flow.
 The upper line shows the progression of the opening pressure, the lower line shows the progression of the closing pressure.
 All characteristics relate to water at 20 °C.

Diagrams - N086

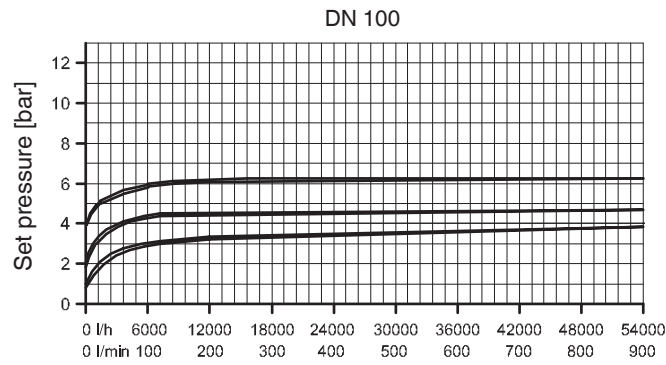
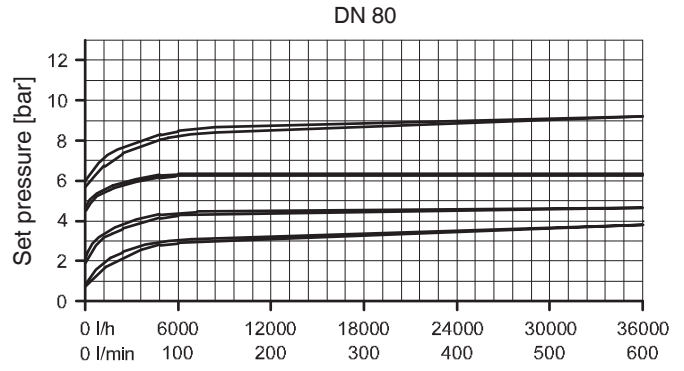
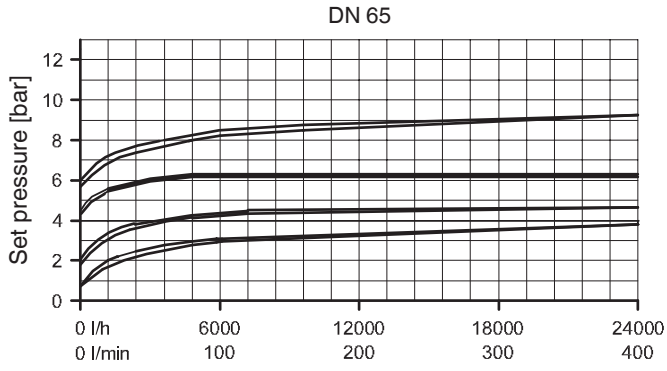

The characteristics in the diagrams show the pressure drop of the set pressure from 0 to max. permissible flow.
 The upper line shows the progression of the opening pressure, the lower line shows the progression of the closing pressure.
 All characteristics relate to water at 20 °C.

Order data

Valve type		Code
Pressure retaining valve	DN 65 - DN 100	N086
Pressure retaining valve	DN 10 - DN 50	N186

Valve body material	Code
PVC-U, grey	1
PVDF	20
PP-B	B5

Body configuration	Code
2/2-way body	D

Diaphragm material	Code
EPDM	14
PTFE/EPDM, PTFE laminated	52

Connection	Code
Spigots DIN	0
Flanges EN 1092 / PN10 / form B, length EN 558, series 1, ISO 5752, basic series 1	4
Union ends with DIN insert (socket)	7
Spigots for IR butt welding	20
Union ends with DIN insert (for IR butt welding)	78

Order example	N186	25	D	0	1	14
Type	N186					
Nominal size		25				
Body configuration (code)			D			
Connection (code)				0		
Valve body material (code)					1	
Diaphragm material (code)						14

Dimensions [mm]

N086, N186

DN	d	L		L1			L2			ø D	h	h1	H
		Connection code 0	Connection code 20	Connection code 4			Connection code 7, 78						
		Material code 1, 20, B5	Material code 20, B5	Material code 1	Material code 20	Material code B5	Material code 1	Material code 20	Material code B5				
10	16	134	158	140	168	-	154	180	180	83	20.0	20.0	137
15	20	134	158	140	168	168	154	182	182	83	20.0	20.0	137
20	25	134	158	140	168	168	154	182	182	83	20.0	20.0	137
25	32	174	198	180	208	208	194	222	222	112	27.0	27.0	199
32	40	174	202	180	212	212	198	230	230	112	27.0	27.0	199
40	50	224	256	230	266	266	252	288	288	165	43.0	43.0	290
50	63	244	256	250	266	266	280	296	296	165	43.0	43.0	290
65	75	284	284	290	-	294	320	-	320	180	47.5	117.0	275
80	90	360	360	370	-	374	396	-	396	250	55.0	155.0	410
100	110	380	380	390	-	394	402	-	424	250	70.0	180.0	450

Code 4

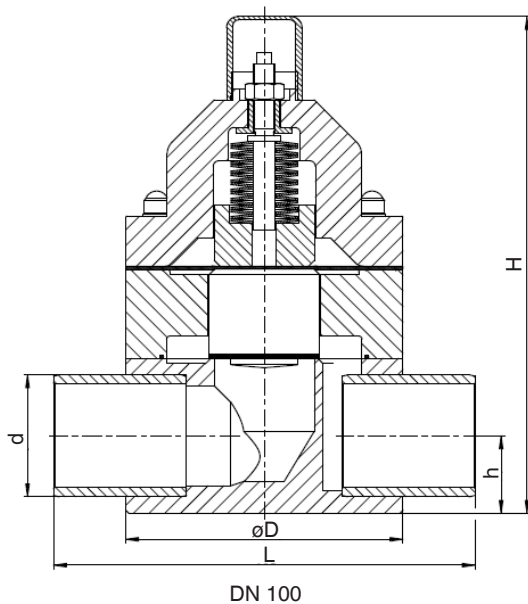
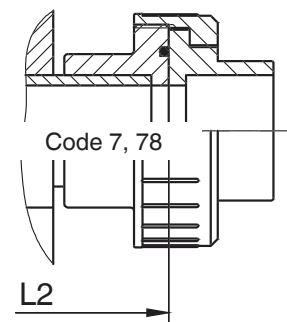
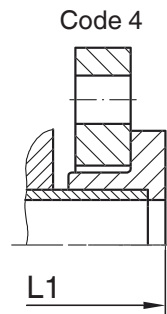
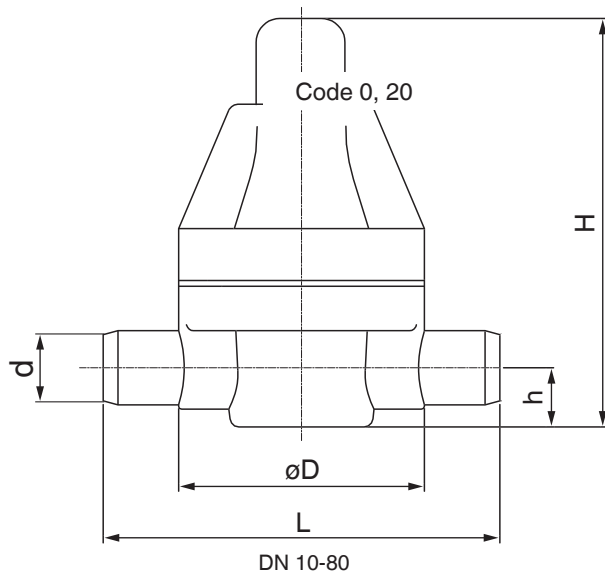

Overview of valve bodies for N186

Connection code	0	4		7	20	78
Material code	1, 20, B5	1, 20	B5	1, 20, B5	20, B5	20, B5
DN						
10	X	X	-	X	-	-
15	X	X	X	X	X	X
20	X	X	X	X	X	X
25	X	X	X	X	X	X
32	X	X	X	X	X	X
40	X	X	X	X	X	X
50	X	X	X	X	X	X

Overview of valve bodies for N086

Connection code	0		4		20	
Material code	1, B5	20	1, B5	20	B5	20
DN						
65	X	X	X	X	X	X
80	X	-	X	-	X	-
100	X	-	X	-	X	-

All rights including copyright and industrial property rights are expressly reserved.

Should there be any doubts or misunderstandings, the German version of this data sheet is the authoritative document!

Subject to alteration · 11/2023 · 88449276