

GEMÜ R690

Pneumatically operated diaphragm valve



Features

- Same mounting height planes over multiple nominal sizes
- Compact system design thanks to flow-optimized high-flow valve bodies
- Reduced control air consumption
- Modified spring sets available for applications with reduced control pressure

Description

The GEMÜ R690 2/2-way diaphragm valve has a low maintenance membrane actuator and is pneumatically operated. Normally Closed (NC), Normally Open (NO) and Double Acting (DA) control functions are available. The high-flow valve body provides compact dimensions at high flow rates.

Technical specifications

- **Media temperature:** 14 to 176 °F
- **Ambient temperature:** 14 to 122 °F
- **Operating pressure :** 0 to 150 psi
- **Body configurations:** 2/2-way body
- **Connection standards:** ANSI | ASTM | BS | DIN | EN | ISO | JIS
- **Body materials:** ABS | Inliner PP-H, grey / outliner PP, reinforced | Inliner PVDF/outliner PP, reinforced | PP, reinforced | PVC-U, grey | PVDF
- **Diaphragm materials:** EPDM | FKM | NBR | PTFE/EPDM
- **Conformities:** EAC | FDA | NSF

Technical data depends on the respective configuration



Product description

Construction



Item	Name	Materials
1	Optical position indicator	PP-H red
2	Actuator	PP- H 30% glass fibre reinforced
3	CONEXO actuator RFID chip (see Conexo information)	
4	Control air connector	Brass
5	Diaphragm	NBR, FKM, EPDM, PTFE / EPDM one-piece, PTFE / EPDM two-piece
6	Valve body	PVC-U, grey ABS PP, reinforced PVDF Inliner PP-H, grey / outliner PP, reinforced Inliner PVDF / outliner PP, reinforced
7	CONEXO diaphragm RFID chip (see Conexo information)	
8	CONEXO body RFID chip (see Conexo information)	

GEMÜ CONEXO

The interaction of valve components that are equipped with RFID chips and an associated IT infrastructure actively increase process reliability.



Thanks to serialization, every valve and every relevant valve component such as the body, actuator or diaphragm, and even automation components, can be clearly traced and read using the CONEXO pen RFID reader. The CONEXO app, which can be installed on mobile devices, not only facilitates and improves the "installation qualification" process, but also makes the maintenance process much more transparent and easier to document. The app actively guides the maintenance technician through the maintenance schedule and directly provides him with all the information assigned to the valve, such as test reports, testing documentation and maintenance histories. The CONEXO portal acts as a central element, helping to collect, manage and process all data.

For further information on GEMÜ CONEXO please visit:

www.gemu-group.com/conexo

Ordering

GEMÜ Conexo must be ordered separately with the ordering option "CONEXO".

Availabilities

Availability of valve bodies

Spigot

MG	DN	Connection type code ¹⁾						
		0			20		30	7X
		Material code ²⁾						
		1	5, 20	71, 75	20	71, 75	1, 4	1, 4, 71, 75
20	15	X	-	X	-	X	X	X
	20	X	-	X	-	X	X	X
	25	X	-	X	-	X	X	X
25	32	X	-	X	-	X	X	X
40	40	X	-	X	-	X	X	X
	50	X	-	X	-	X	X	X
50	65	X	X	-	X	-	X	-
80	80	X	X	-	X	-	X	-
100	100	X	X	-	X	-	X	-

MG = diaphragm size, X = standard

1) **Connection type**

Code 0: Spigot DIN

Code 20: Spigot for IR butt welding

Code 30: Spigot – inch, for welding or solvent cementing, depending on the body material

Code 7X: Body with threaded spigots for unions

2) **Valve body material**

Code 1: PVC-U, grey

Code 4: ABS

Code 5: PP, reinforced

Code 20: PVDF

Code 71: Inliner PP-H, grey, outliner PP, reinforced

Code 75: Inliner PVDF/outliner PP, reinforced

Union end

MG	DN	Connection type code ¹⁾											
		7				7R, 3P	33			3M	3T	78	
		Material code ²⁾											
		1	4	71	75	1	1	4	1	1	71	75	
20	15	X	X	X	X	X	X	X	X	-	X	X	
	20	X	X	X	X	X	X	X	X	X	X	X	
	25	X	X	X	X	X	X	X	X	X	X	X	
25	32	X	X	X	X	X	X	X	X	X	X	X	
40	40	X	X	X	X	X	X	X	X	X	X	X	
	50	X	X	X	X	X	X	X	X	X	X	X	

MG = diaphragm size, X = standard

1) **Connection type**

- Code 7: Union end with insert (socket) – DIN
- Code 7R: Union end with insert (Rp threaded socket) – DIN
- Code 33: Union end with inch insert – BS (socket)
- Code 3M: Union end with inch insert – ASTM (socket)
- Code 3P: Union end with insert (NPT threaded socket)
- Code 3T: Union end with insert – JIS (socket)
- Code 78: Union end with insert (for IR butt welding) – DIN

2) **Valve body material**

- Code 1: PVC-U, grey
- Code 4: ABS
- Code 71: Inliner PP-H, grey, outliner PP, reinforced
- Code 75: Inliner PVDF/outliner PP, reinforced

Flange

MG	DN	Connection type code ¹⁾									
		4					39				
		Material code ²⁾									
		1	5	20	71	75	1	5	20	71	75
20	15	X	-	-	X	X	X	-	-	X	X
	20	X	-	-	X	X	X	-	-	X	X
	25	X	-	-	X	X	X	-	-	X	X
25	32	X	-	-	X	X	X	-	-	X	X
40	40	X	-	-	X	X	X	-	-	X	X
	50	X	-	-	X	X	X	-	-	X	X
50	65	X	X	X	-	-	X	X	X	-	-
80	80	X	X	X	-	-	X	X	X	-	-
100	100	X	X	X	-	-	X	X	X	-	-

MG = diaphragm size, X = standard

1) **Connection type**

- Code 4: Flange EN 1092, PN 10, form B, face-to-face dimension FTF EN 558 series 1, ISO 5752, basic series 1
- Code 39: Flange ANSI Class 125/150 RF, length only for body configuration D acc. to EN 558 series 1, ISO 5752, basic series 1

2) **Valve body material**

- Code 1: PVC-U, grey
- Code 5: PP, reinforced
- Code 20: PVDF
- Code 71: Inliner PP-H, grey, outliner PP, reinforced
- Code 75: Inliner PVDF/outliner PP, reinforced

Availability - Product conformity NSF (special function code N)

MG	DN	Connection type code ¹⁾									Material code	Diaphragm material (code)
		0	4	7	7R	30	33	39	3M	3T		
20	15	X	X	X	X	X	X	X	X	-	X	X
	20	X	X	X	X	X	X	X	X	X	X	X
	25	X	X	X	X	X	X	X	X	X	X	X
25	32	X	X	X	X	X	X	X	X	X	X	X
40	40	X	X	X	X	X	X	X	X	X	X	X
	50	X	X	X	X	X	X	X	X	X	X	X
50	65	X	X	-	-	X	-	X	-	-	X	X
80	80	X	X	-	-	X	-	X	-	-	X	X
100	100	X	X	-	-	X	-	X	-	-	X	X

MG = diaphragm size

1) **Connection type**

Code 0: Spigot DIN

Code 4: Flange EN 1092, PN 10, form B, face-to-face dimension FTF EN 558 series 1, ISO 5752, basic series 1

Code 7: Union end with insert (socket) – DIN

Code 30: Spigot – inch, for welding or solvent cementing, depending on the body material

Code 33: Union end with inch insert – BS (socket)

Code 39: Flange ANSI Class 125/150 RF, length only for body configuration D acc. to EN 558 series 1, ISO 5752, basic series 1

Code 3M: Union end with inch insert – ASTM (socket)

Code 3T: Union end with insert – JIS (socket)

Code 7R: Union end with insert (Rp threaded socket) – DIN

Order data

The order data provide an overview of standard configurations.

Please check the availability before ordering. Other configurations available on request.

Order codes

1 Type	Code
Diaphragm valve, pneumatically operated, plastic membrane actuator	R690

2 DN	Code
DN 15	15
DN 20	20
DN 25	25
DN 32	32
DN 40	40
DN 50	50
DN 65	65
DN 80	80
DN 100	100

3 Body configuration	Code
2/2-way body	D

4 Connection type	Code
Spigot	
Spigot DIN	0
Spigot for IR butt welding	20
Spigot – inch, for welding or solvent cementing, depending on the body material	30
Body with threaded spigots for unions	7X
Union end	
Union end with insert (socket) – DIN	7
Union end with insert (Rp threaded socket) – DIN	7R
Union end with inch insert – BS (socket)	33
Union end with inch insert – ASTM (socket)	3M
Union end with insert – JIS (socket)	3T
Union end with insert (for IR butt welding) – DIN	78
Flange	
Flange EN 1092, PN 10, form B, face-to-face dimension FTF EN 558 series 1, ISO 5752, basic series 1	4
Flange ANSI Class 125/150 RF, length only for body configuration D acc. to EN 558 series 1, ISO 5752, basic series 1	39

5 Valve body material	Code
PVC-U, grey	1
ABS	4
PP, reinforced	5

5 Valve body material	Code
PVDF	20
Inliner PP-H, grey, outliner PP, reinforced	71
Inliner PVDF/outliner PP, reinforced	75

6 Diaphragm material	Code
Elastomer	
NBR	2
FKM	4
EPDM	17
EPDM	29
PTFE	
PTFE/EPDM one-piece	54
PTFE/EPDM two-piece	5M
Note: The PTFE/EPDM diaphragm (code 5M) is available from diaphragm size 25.	

7 Control function	Code
Normally closed (NC)	1
Normally open (NO)	2
Double acting (DA)	3

8 Actuator version	Code
Actuator size EDL (diaphragm size 20)	EDL
Diaphragm size 20	EDM
Diaphragm size 20	EDN
Actuator size FDL (diaphragm size 25)	FDL
Actuator size FDM	FDM
Actuator size FDN	FDN
Actuator size HDL (diaphragm size 40)	HDL
Actuator size HDM	HDM
Actuator size HDN	HDN
Actuator size JDL	JDL
Actuator size JDM	JDM
Actuator size JDN	JDN
Actuator size MDN (diaphragm size 80)	MDN
Actuator size NDN (diaphragm size 100)	NDN

9 Special version	Code
NSF 61 water approval	N

10 CONEXO	Code
Integrated RFID chip for electronic identification and traceability	C
Without	

Order codes

Order option	Code	Description
1 Type	R690	Diaphragm valve, pneumatically operated, plastic membrane actuator
2 DN	20	DN 20
3 Body configuration	D	2/2-way body
4 Connection type	7	Union end with insert (socket) – DIN
5 Valve body material	1	PVC-U, grey
6 Diaphragm material	17	EPDM
7 Control function	1	Normally closed (NC)
8 Actuator version	EDN	Diaphragm size 20
9 Special version	N	NSF 61 water approval
10 CONEXO		Without

Technical data

Medium

Working medium: Corrosive, inert, gaseous and liquid media which have no negative impact on the physical and chemical properties of the body and diaphragm material.

Control medium: Inert gases

Temperature

Media temperature:

Valve body material	
PVC-U, grey (code 1)	50 – 140 °F
ABS (code 4)	14 – 140 °F
PP, reinforced (code 5)	41 – 176 °F
PVDF (code 20)	14 – 176 °F
Inliner PP-H grey / outliner PP, reinforced (code 71)	41 – 176 °F
Inliner PVDF / outliner PP, reinforced (code 75)	14 – 176 °F

Ambient temperature:

Valve body material	
PVC-U, grey (code 1)	50 – 122 °F
ABS (code 4)	14 – 122 °F
PP, reinforced (code 5)	41 – 122 °F
PVDF (code 20)	14 – 122 °F
Inliner PP-H grey / outliner PP, reinforced (code 71)	41 – 122 °F
Inliner PVDF / outliner PP, reinforced (code 75)	23 – 122 °F

Control medium temperature: 32 – 104 °F

Storage temperature: 32 – 104 °F

Pressure

Operating pressure:

MG	DN	NPS	Actuator size*	Control function	Diaphragm materials	
					Elastomer	PTFE
20	15, 20, 25	1/2", 3/4", 1"	EDL	1	0 - 45	0 - 45
			EDM	1	0 - 90	0 - 90
			EDN	1	0 - 150	0 - 150
			EDN	2, 3	0 - 150	0 - 150
25	32	1 1/4"	FDL	1	0 - 45	0 - 45
			FDM	1	0 - 90	0 - 90
			FDN	1	0 - 150	0 - 150
			FDN	2, 3	0 - 150	0 - 150
40	40, 50	1 1/2", 2"	HDL	1	0 - 60	0 - 60
			HDM	1	0 - 90	0 - 90
			HDN	1	0 - 150	0 - 150
			HDN	2, 3	0 - 150	0 - 150
50	65	2 1/2"	JDL	1	0 - 45	0 - 45
			JDM	1	0 - 90	0 - 90
			JDN	1	0 - 150	0 - 150
			JDN	2, 3	0 - 150	0 - 150
80	80	3"	MDN	1, 2, 3	0 - 120	0 - 90
100	100	4"	NDN	1, 2, 3	0 - 90	0 - 60

MG = diaphragm size

* Actuator sizes _DL, _DM with weaker spring set for operating the system with low wear on the diaphragm and for vacuum applications.

All pressures are psi - gauge pressures. Operating pressure values were determined with static operating pressure applied on one side of a closed valve. Sealing at the valve seat and atmospheric sealing is ensured for the given values.

Information on operating pressures applied on both sides and for high purity media on request.

Pressure rating:

PN 10

Pressure/temperature correlation:

Valve body material		Temperature in °C (valve body)											
Materials	Code	-10	±0	5	10	20	25	30	40	50	60	70	80
PVC-U	1	-	-	-	150.0	150.0	150.0	120.0	90.0	50.76	21.76	-	-
ABS	4	150.0	150.0	150.0	150.0	150.0	150.0	120.0	90.0	60.0	30.0	-	-
PP	5	-	-	150.0	150.0	150.0	150.0	123.2	105.0	79.77	60.0	39.16	21.76
PP-H	71	-	-	150.0	150.0	150.0	150.0	123.2	105.0	79.77	60.0	39.16	21.76
PVDF	20	150.0	150.0	150.0	150.0	150.0	150.0	130.5	120.0	102.9	91.38	78.32	68.17
PVDF	75	150.0	150.0	150.0	150.0	150.0	150.0	130.5	120.0	102.9	91.38	78.32	68.17

Data for extended temperature ranges on request. Please note that the ambient temperature and media temperature generate a combined temperature at the valve body which must not exceed the above values.

Control pressure:

MG	DN	NPS	Actuator size	Control function	Control pressure*
20	15, 20, 25	1/2", 3/4", 1"	EDL	1	43.5 - 105.0
			EDM	1	55,0 - 105.0
			EDN	1	75.0 - 105.0
			EDN	2, 3	max. 90.0
25	32	1 1/4"	FDL	1	36.5 - 90.0
			FDM	1	55,0 - 90.0
			FDN	1	75.0 - 105.0
			FDN	2, 3	max. 80.0
40	40, 50	1 1/2", 2"	HDL	1	45.0 - 105.0
			HDM	1	55.0 - 90.0
			HDN	1	75.0 - 105.0
			HDN	2, 3	max. 80.0
50	65	2 1/2"	JDL	1	45.0 - 90.0
			JDM	1	55.0 - 90.0
			JDN	1	80.0 - 105.0
			JDN	2, 3	max. 75.0
80	80	3"	MDN	1	75.0 - 105.0
			MDN	2	max. 75.0
			MDN	3	max. 65.0
100	100	4"	NDN	1	80.0 - 105.0
			NDN	2	max. 75.0
			NDN	3	max. 65.0

MG = diaphragm size

*For required control pressure depending on operating pressure see diagram

Control pressure characteristic DN 15 - 100 (EPDM, FPM)

Control function 2 and 3

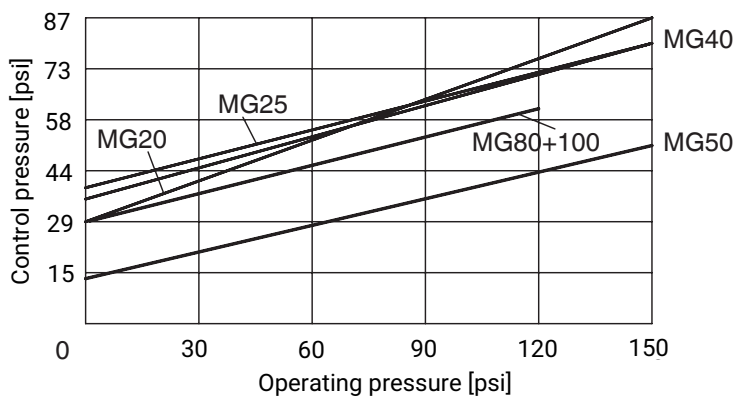

The control pressure depending on the prevailing operating pressure, as shown in the diagram, is intended as a guide for operating the system with low wear on the diaphragm.

Technical data

Control pressure:

MG	DN	Kv values
20	15	7.0
	20	11.7
	25	14.0
25	32	23.4
40	40	49.1
	50	53.8
50	65	81.9
80	80	140.4
100	100	221.1

MG = diaphragm size, Kv values in m³/h

Kv values determined acc.to DIN EN 60534 standard, inlet pressure 5 bar, Δp 1 bar, PVC-U valve body and soft elastomer diaphragm.

The Kv values for other product configurations (e.g. other diaphragm or body materials) may differ. In general, all diaphragms are subject to the influences of pressure, temperature, the process and their tightening torques. Therefore the Kv values may exceed the tolerance limits of the standard.

The Kv value curve (Kv value dependent on valve stroke) can vary depending on the diaphragm material and duration of use.

Filling volume:

Diaphragm size 20	0.10 dm ³
Diaphragm size 25	0.20 dm ³
Diaphragm size 40	0.55 dm ³
Diaphragm size 50	1.06 dm ³
Diaphragm size 80	2.50 dm ³
Diaphragm size 100	2.50 dm ³

Product conformity

Pressure Equipment Directive: 2014/68/EU

Food: FDA*
Regulation (EC) No. 1935/2004
Regulation (EC) No. 10/2011*

EAC: TR CU 010/2011

Drinking water: NSF/ANSI*
* depending on version and/or operating parameters

Materials

Materials:

Diaphragm material	O-ring material
PTFE	FKM
NBR	EPDM
FKM	FKM
EPDM	EPDM

Mechanical data

Weight:

Actuator

MG	Actuator size	Control function	Weight
20	EDL, EDM, EDN	1	1.54
	EDL, EDM, EDN	2 + 3	1.10
25	FDL, FDM, FDN	1	3.53
	FDL, FDM, FDN	2 + 3	2.20
40	HDL, HDM, HDN	1	7.72
	HDL, HDM, HDN	2 + 3	4.41
50	JDL, JDM, JDN	1	12.57
	JDL, JDM, JDN	2 + 3	8.38
80	MDN	1	24.91
	MDN	2 + 3	17.86
100	NDN	1	25.35
	NDN	2 + 3	20.72

Valve body

MG	DN	Spigot		Union end				Flange
		Connection type code						
		0, 30	20	3P, 7, 7R	33	3M, 3T	78	
20	15	0.26	0.22	0.37	0.53	0.57	0.60	1.48
	20	0.29	0.26	0.46	0.62	0.66	0.79	1.85
	25	0.35	0.31	0.57	0.73	0.84	0.82	2.82
25	32	0.49	0.40	0.88	1.54	1.61	1.39	4.17
40	40	1.10	0.88	1.61	1.83	2.05	2.49	5.20
	50	1.26	1.04	2.20	3.09	3.31	3.53	6.79
50	65	2.03	7.87	-	-	-	-	7.05
80	80	8.82	7.28	-	-	-	-	14.77
100	100	9.70	8.82	-	-	-	-	18.08

MG = diaphragm size
Weight in lb

Installation position: Optional

Flow direction: Optional

Dimensions

Actuator dimensions

Actuator - Control function 1

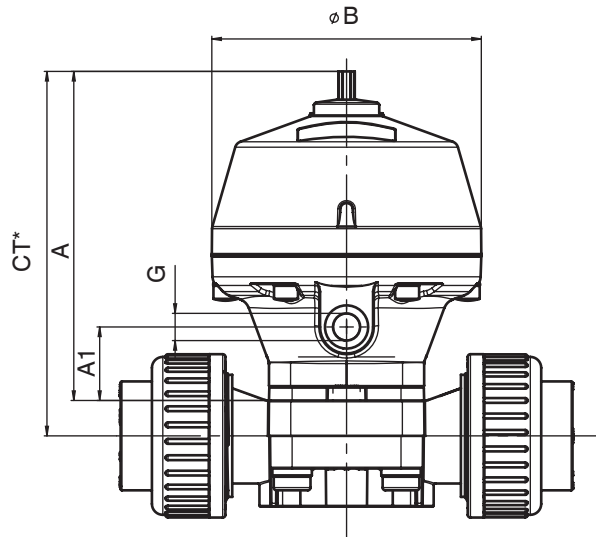

MG	DN	Actuator size	ϕB	A	A1	G
20	15 - 25	EDL, EDM, EDN	3.94	4.69	1.06	G 1/4
25	32	FDL, FDM, FDN	5.12	5.71	1.10	G 1/4
40	40 - 50	HDL, HDM, HDN	6.69	7.80	2.05	G 1/4
50	65	JDL, JDM, JDN	8.31	9.65	3.54	G 1/4
80	80	MDN	10.24	12.48	5.00	G 1/4
100	100	NDN	10.24	13.74	5.87	G 1/4

Dimensions in inch

MG = diaphragm size

* CT = A + H1 (see body dimensions)

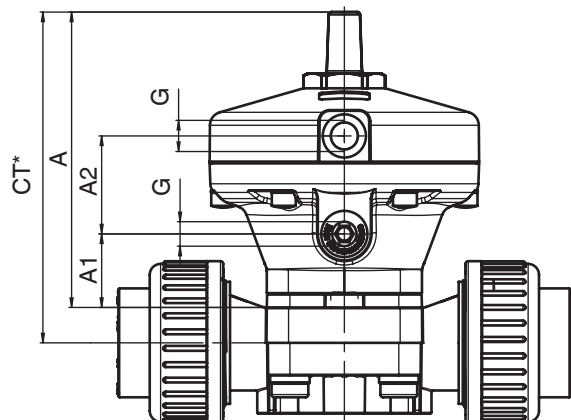
Actuator - Control function 2 and 3

MG	DN	Actuator size	A	A1	A2	G
20	15 - 25	EDL, EDM, EDN	4.29	1.06	1.42	G 1/4
25	32	FDL, FDM, FDN	4.84	1.10	1.81	G 1/4
40	40 - 50	HDL, HDM, HDN	6.42	2.05	2.17	G 1/4
50	65	JDL, JDM, JDN	8.11	3.54	1.89	G 1/4
80	80	MDN	10.63	5.00	1.61	G 1/4
100	100	NDN	12.09	5.87	1.81	G 1/4

Dimensions in inch

MG = diaphragm size

* CT = A + H1 (see body dimensions)

Body dimensions

Spigot DIN/inch (code 0, 30)

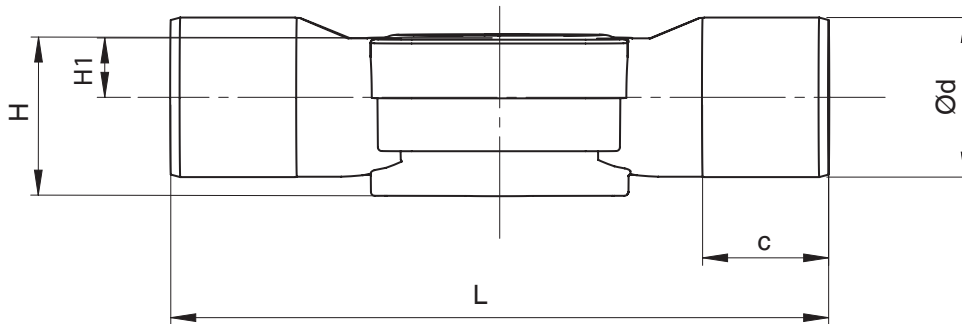

Connection type spigot DIN (code 0)¹⁾, body material PVC-U (code 1), PP (code 5), PVDF (code 20), inliner/outliner (code 71, 75)²⁾

MG	DN	NPS	c			ød	H			H1	L
			Material				Material				
			1	5, 20	71, 75		1	5, 20	71, 75		
20	15	1/2"	0.63	-	0.71	0.79	1.42	-	1.42	0.39	4.88
	20	3/4"	0.75	-	0.75	0.98	1.50	-	1.50	0.47	5.67
	25	1"	0.87	-	0.87	1.26	1.54	-	1.54	0.51	6.06
25	32	1 1/4"	1.26	-	1.26	1.57	1.61	-	1.61	0.59	6.85
40	40	1 1/2"	1.38	-	1.02	1.97	2.49	-	2.49	0.91	7.64
	50	2"	1.50	-	1.30	2.48	2.49	-	2.49	0.91	8.82
50	65	2 1/2"	1.81	1.81	-	2.95	3.10	3.10	-	1.53	11.18
80	80	3"	2.01	2.01	-	3.54	4.61	4.61	-	2.44	11.81
100	100	4"	2.40	2.40	-	4.33	5.51	5.51	-	2.95	13.39

Connection type spigot - inch (code 30)¹⁾, body material PVC-U (code 1), ABS (code 4)²⁾

MG	DN	NPS	c	ød	H	H1	L
20	15	1/2"	0.94	0.84	1.42	0.39	5.55
	20	3/4"	1.06	1.05	1.50	0.47	5.67
	25	1"	1.18	1.32	1.54	0.51	6.06
25	32	1 1/4"	1.30	1.66	1.61	0.59	6.85
40	40	1 1/2"	1.38	1.90	2.49	0.91	7.64
	50	2"	1.57	2.37	2.49	0.91	8.82
50	65	2 1/2"	1.81	2.87	3.10	1.53	11.18
80	80	3"	2.01	3.50	4.61	2.44	11.81
100	100	4"	2.40	4.50	5.51	2.95	13.39

Dimensions in inch

MG = diaphragm size

1) **Connection type**

Code 0: Spigot DIN

Code 30: Spigot - inch, for welding or solvent cementing, depending on the body material

2) **Valve body material**

Code 1: PVC-U, grey

Code 4: ABS

Code 5: PP, reinforced

Code 20: PVDF

Code 71: Inliner PP-H, grey, outliner PP, reinforced

Code 75: Inliner PVDF/outliner PP, reinforced

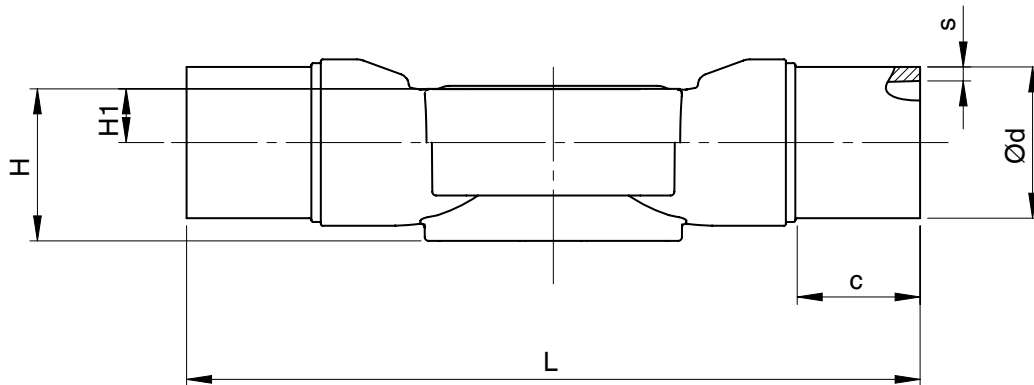
Spigot IR (code 20)**Connection type spigot IR (code 20)¹⁾, body material inliner/outliner (code 71, 75)²⁾**

MG	DN	NPS	c	ød	H	H1	L	s	
								Material	
								71	75
20	15	1/2"	1.30	0.79	1.42	0.39	6.06	0.07	0.07
	20	3/4"	1.30	0.98	1.50	0.47	6.06	0.09	0.07
	25	1"	1.30	1.26	1.54	0.51	6.06	0.11	0.09
25	32	1¼"	1.30	1.57	1.61	0.59	7.64	0.15	0.09
40	40	1½"	1.30	1.97	2.49	0.91	7.64	0.18	0.12
	50	2"	1.30	2.48	2.49	0.91	8.82	0.23	0.12

Connection type spigot IR (code 20)¹⁾, body material PVDF (code 20)²⁾

MG	DN	NPS	c	ød	H	H1	L	s
50	65	2½"	1.69	2.95	3.10	1.53	11.18	0.14
80	80	3"	2.01	3.54	4.61	2.44	11.81	0.17
100	100	4"	2.32	4.33	5.51	2.95	13.39	0.21

Dimensions in inch

MG = diaphragm size

1) Connection type

Code 20: Spigot for IR butt welding

2) Valve body material

Code 20: PVDF

Code 71: Inliner PP-H, grey, outliner PP, reinforced

Code 75: Inliner PVDF/outliner PP, reinforced

Union end DIN (code 7)

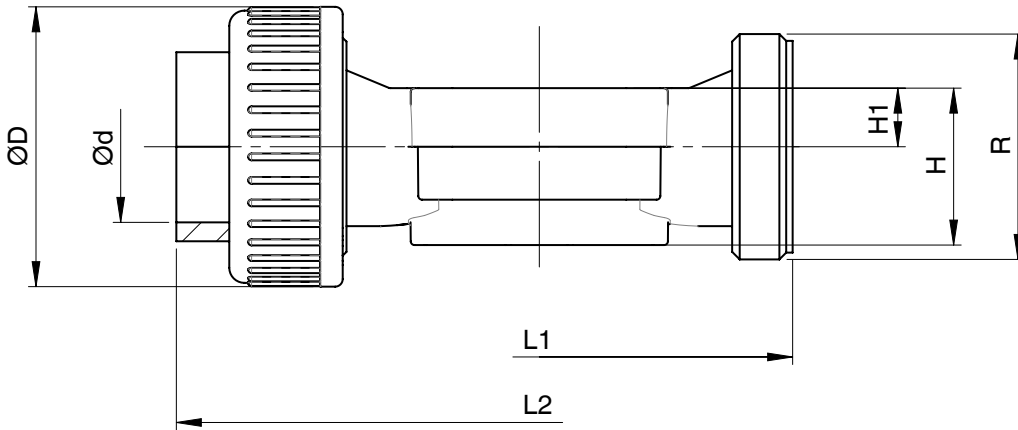

Connection type union end (code 7)¹⁾, body material PVC-U (code 1), ABS (code 4), inliner/outliner (code 71, 75)²⁾, diaphragm sizes 20 – 40

MG	DN	NPS	ød	øD	H	H1	L1	L2				R
								Material				
								1	4	71	75	
20	15	1/2"	0.79	1.69	1.42	0.39	4.25	5.75	5.91	5.63	5.75	G 1
	20	3/4"	0.98	2.09	1.50	0.47	4.25	5.98	6.14	5.75	5.91	G 1¼
	25	1"	1.26	2.36	1.54	0.51	4.57	6.54	6.69	6.22	6.38	G 1½
25	32	1¼"	1.57	2.91	1.61	0.59	5.28	7.56	7.72	7.13	7.24	G 2
40	40	1½"	1.97	3.27	2.49	0.91	6.06	8.74	8.74	8.15	8.27	G 2¼
	50	2"	2.48	4.06	2.49	0.91	7.24	10.47	10.47	9.65	9.76	G 2¾

Dimensions in inch
 MG = diaphragm size

- 1) **Connection type**
 Code 7: Union end with insert (socket) – DIN
- 2) **Valve body material**
 Code 1: PVC-U, grey
 Code 4: ABS
 Code 71: Inliner PP-H, grey, outliner PP, reinforced
 Code 75: Inliner PVDF/outliner PP, reinforced

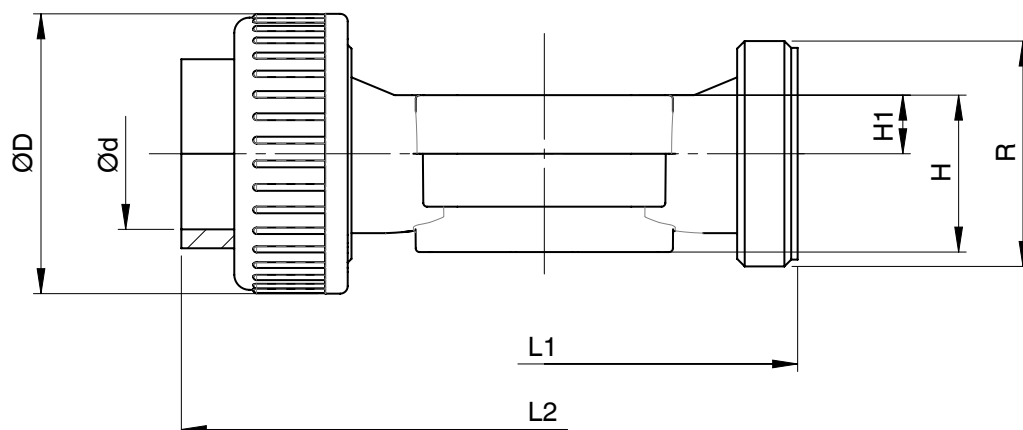
Union end inch (code 33, 3M, 3T)**Connection type union end inch (code 33, 3M, 3T)¹⁾, body material PVC-U (code 1)²⁾, diaphragm sizes 20 - 40**

MG	DN	NPS	ød			øD			H	H1	L1	L2			R	
			Connection type			Connection type						Connection type			Connection type	
			33	3M	3T	33, 3M	3T	33				3M	3T	33	3M	3T
20	15	1/2"	0.84	0.84	0.87	1.69	2.09 *	1.42	0.39	4.25	5.75	6.22	5.98	G 1	G 1 1/4 *	
	20	3/4"	1.06	1.05	1.02	2.09	2.09	1.50	0.47	4.25	5.98	6.46	5.98	G 1 1/4	G 1 1/4	
	25	1"	1.32	1.32	1.26	2.36	2.36	1.54	0.51	4.57	6.54	7.09	6.54	G 1 1/2	G 1 1/2	
25	32	1 1/4"	1.67	1.66	1.50	2.91	2.91	1.61	0.59	5.28	7.56	8.03	7.56	G 2	G 2	
40	40	1 1/2"	1.90	1.90	1.89	3.27	3.27	2.49	0.91	6.06	8.74	9.06	8.74	G 2 1/4	G 2 1/4	
	50	2"	2.38	2.38	2.36	4.06	4.06	2.49	0.91	7.24	10.39	10.47	10.47	G 2 3/4	G 2 3/4	

Connection type BS (code 33)¹⁾, body material ABS (code 4)²⁾

MG	DN	NPS	ød	øD	H	H1	L1	L2	R
20	15	1/2"	0.84	1.69	1.42	0.39	4.25	5.91	G 1
	20	3/4"	1.06	2.09	1.50	0.47	4.25	6.14	G 1 1/4
	25	1"	1.32	2.36	1.54	0.51	4.57	6.69	G 1 1/2
25	32	1 1/4"	1.67	2.91	1.61	0.59	5.28	7.80	G 2
40	40	1 1/2"	1.90	3.27	2.49	0.91	6.06	8.66	G 2 1/4
	50	2"	2.38	4.06	2.49	0.91	7.24	10.39	G 2 3/4

Dimensions in inch

MG = diaphragm size

* Insert requires valve body DN 20

1) Connection type

Code 33: Union end with inch insert – BS (socket)

Code 3M: Union end with inch insert – ASTM (socket)

Code 3T: Union end with insert – JIS (socket)

2) Valve body material

Code 1: PVC-U, grey

Code 4: ABS

Union end DIN, IR butt welding (code 78)

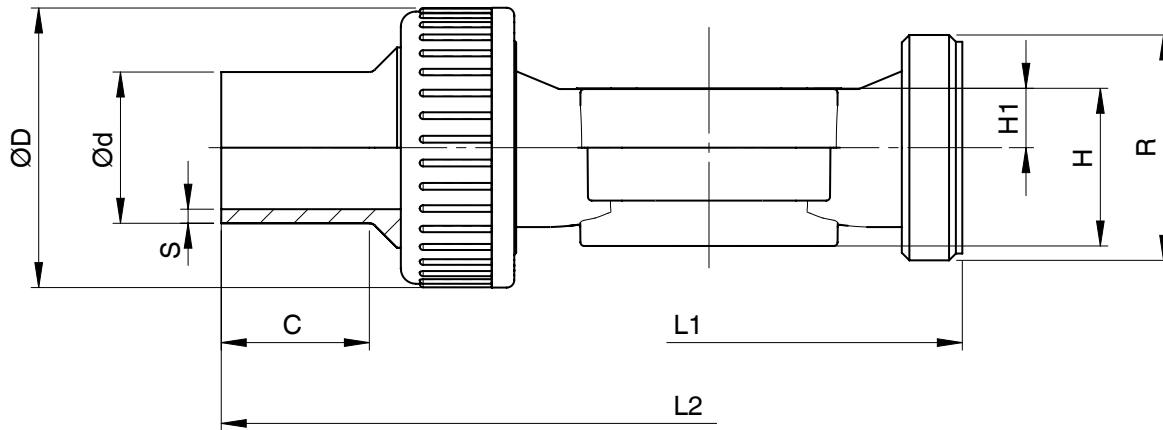

Connection type union end DIN, IR butt welding (code 78)¹⁾, body materials inliner/outliner (code 71, 75)²⁾

MG	DN	NPS	c	ød	øD	H	H1	L1	L2	R	s	
											Material	
											71	75
20	15	1/2"	1.42	0.03	1.69	1.42	0.39	4.25	8.43	G 1	0.07	0.07
	20	3/4"	1.46	0.04	2.09	1.50	0.47	4.25	8.66	G 1¼	0.09	0.07
	25	1"	1.54	1.26	2.36	1.54	0.51	4.57	9.21	G 1½	0.11	0.09
25	32	1¼"	1.54	1.57	2.91	1.61	0.59	5.28	10.16	G 2	0.15	0.09
40	40	1½"	1.69	1.97	3.27	2.49	0.91	6.06	11.18	G 2¼	0.18	0.12
	50	2"	1.69	2.48	4.06	2.49	0.91	7.24	12.60	G 2¾	0.23	0.12

Dimensions in inch

MG = diaphragm size

1) **Connection type**

Code 78: Union end with insert (for IR butt welding) – DIN

2) **Valve body material**

Code 71: Inliner PP-H, grey, outliner PP, reinforced

Code 75: Inliner PVDF/outliner PP, reinforced

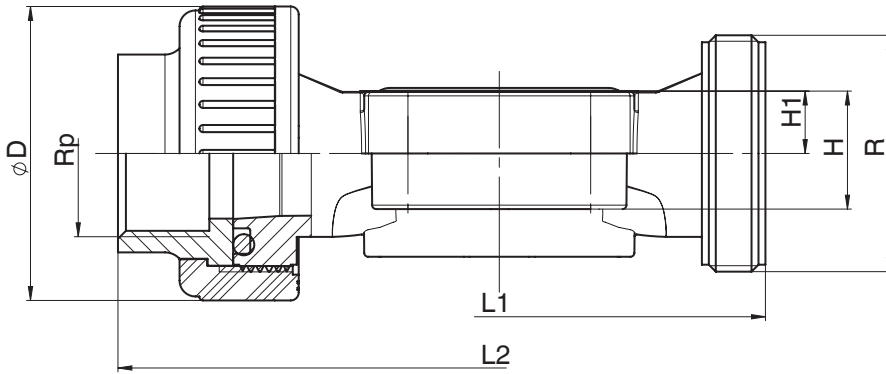
Union end Rp (code 7R)**Connection type union end Rp (code 7R), NPT (code 3P)¹⁾, body material PVC-U (code 1)²⁾**

MG	DN	NPS	ϕD	H	H1	L1	L2	R	Rp/NPT
20	15	1/2"	1.69	1.42	0.39	4.25	5.75	G 1	1/2
	20	3/4"	2.09	1.50	0.47	4.25	5.98	G 1¼	3/4
	25	1"	2.36	1.54	0.51	4.57	6.54	G 1½	1
25	32	1¼"	2.91	1.61	0.59	5.28	7.56	G 2	1¼
40	40	1½"	3.27	2.49	0.91	6.06	8.74	G 2¼	1½
	50	2"	4.06	2.49	0.91	7.24	10.47	G 2¾	2

Dimensions in inch

MG = diaphragm size

1) Connection type

Code 7R: Union end with insert (Rp threaded socket) – DIN

Code 3P: Union end with insert (NPT threaded socket)

2) Valve body material

Code 1: PVC-U, grey

Flange EN (code 4)

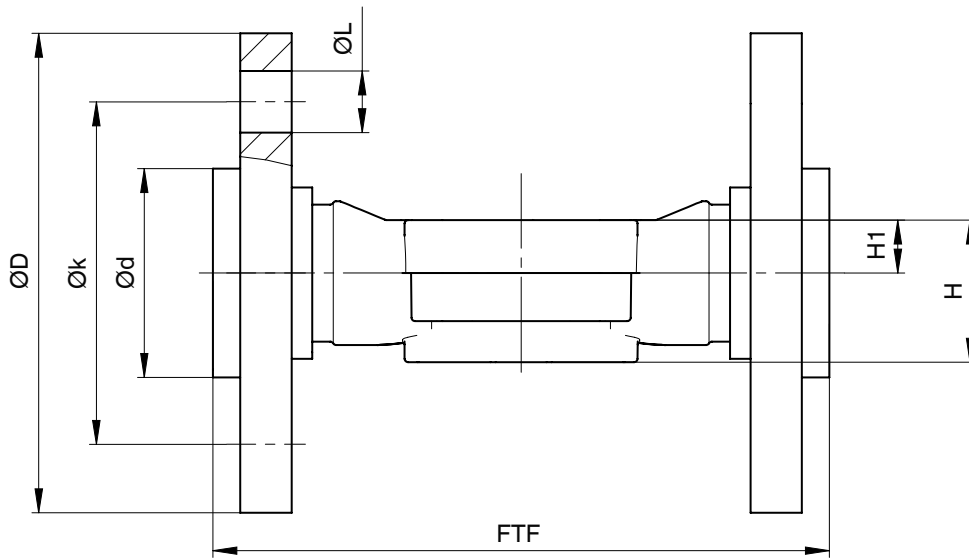

Connection type flange EN (code 4)¹⁾, body material PVC-U (code 1)²⁾

MG	DN	NPS	ød	øD	FTF	H	H1	øk	øL	n
20	15	1/2"	1.34	3.74	5.12	1.42	0.39	2.56	0.55	4
	20	3/4"	1.61	4.13	5.91	1.50	0.47	2.95	0.55	4
	25	1"	1.97	4.53	6.30	1.54	0.51	3.35	0.55	4
25	32	1¼"	2.40	5.51	7.09	1.61	0.59	3.94	0.71	4
40	40	1½"	2.87	5.91	7.87	2.49	0.91	4.33	0.71	4
	50	2"	3.54	6.50	9.06	2.49	0.91	4.92	0.71	4
50	65	2½"	4.17	7.28	11.42	3.10	1.53	5.71	0.71	4
80	80	3"	4.92	7.87	12.20	4.61	2.44	6.30	0.71	8
100	100	4"	5.91	8.66	13.78	5.51	2.95	7.09	0.71	8

Connection type flange EN (code 4)¹⁾, body materials PP (code 5), PVDF (code 20)²⁾

MG	DN	NPS	ød		øD	FTF	H	H1	øk	øL	n
			Material								
			5	20							
50	65	2½"	4.80	4.72	7.28	11.42	3.10	1.53	5.71	0.71	4
80	80	3"	5.43	4.92	7.87	12.20	4.61	2.44	6.30	0.71	8
100	100	4"	6.22	5.91	8.66	13.78	5.51	2.95	7.09	0.71	8

Dimensions in inch

MG = diaphragm size

n = number of bolts

1) **Connection type**

Code 4: Flange EN 1092, PN 10, form B, face-to-face dimension FTF EN 558 series 1, ISO 5752, basic series 1

2) **Valve body material**

Code 1: PVC-U, grey

Code 5: PP, reinforced

Code 20: PVDF

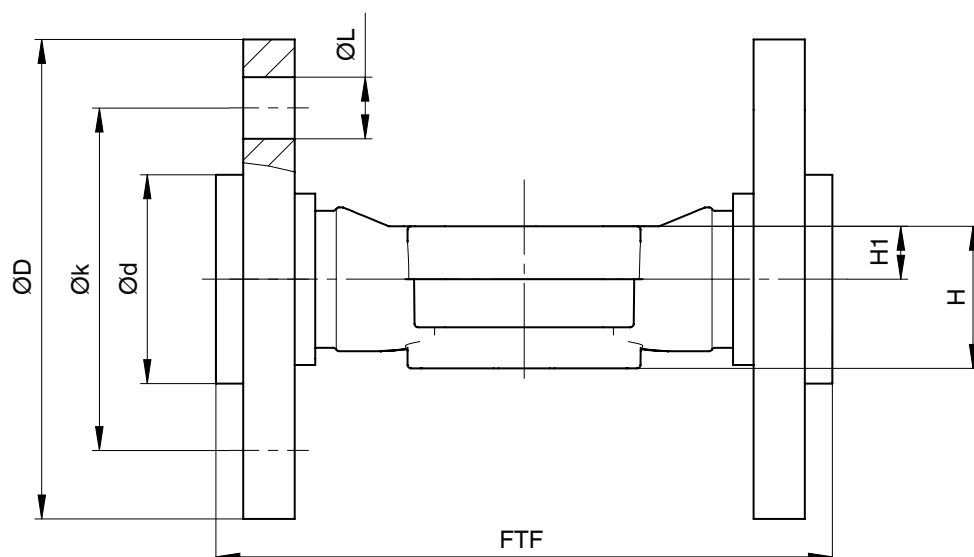

Connection type flange EN (code 4)¹⁾, body material inliner/outliner (code 71, 75)²⁾

MG	DN	NPS	ϕd	ϕD	FTF	H	H1	ϕk	ϕL	n
20	15	1/2"	1.77	3.74	5.12	1.42	0.39	2.56	0.55	4
	20	3/4"	2.28	4.13	5.91	1.50	0.47	2.95	0.55	4
	25	1"	2.68	4.53	6.30	1.54	0.51	3.35	0.55	4
25	32	1 1/4"	3.07	5.51	7.09	1.61	0.59	3.94	0.71	4
40	40	1 1/2"	3.46	5.91	7.87	2.49	0.91	4.33	0.71	4
	50	2"	4.02	6.50	9.06	2.49	0.91	4.92	0.71	4

Dimensions in inch

MG = diaphragm size

n = number of bolts

1) **Connection type**

Code 4: Flange EN 1092, PN 10, form B, face-to-face dimension FTF EN 558 series 1, ISO 5752, basic series 1

2) **Valve body material**

Code 71: Inliner PP-H, grey, outliner PP, reinforced

Code 75: Inliner PVDF/outliner PP, reinforced

Flange ANSI Class (code 39)

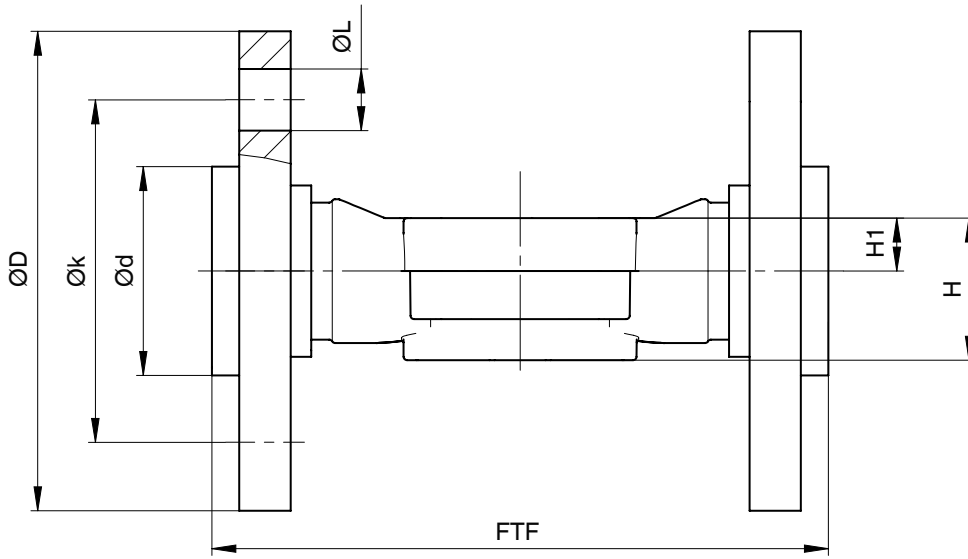

Connection type flange ANSI (code 39)¹⁾, body material PVC-U (code 1)²⁾

MG	DN	NPS	ød	øD	FTF	H	H1	øk	øL	n
20	15	1/2"	1.34	3.74	5.12	1.42	0.39	2.36	0.63	4
	20	3/4"	1.61	4.13	5.91	1.50	0.47	2.76	0.63	4
	25	1"	1.97	4.53	6.30	1.54	0.51	3.11	0.63	4
25	32	1¼"	2.40	5.51	7.09	1.61	0.59	3.50	0.63	4
40	40	1½"	2.87	5.91	7.87	2.49	0.91	3.86	0.63	4
	50	2"	3.54	6.50	9.06	2.49	0.91	4.76	0.75	4
50	65	2½"	4.17	7.28	11.42	3.10	1.53	5.51	0.75	4
80	80	3"	4.92	7.87	12.20	4.61	2.44	5.98	0.75	4
100	100	4"	5.91	9.02	13.78	5.51	2.95	7.48	0.75	8

Connection type flange ANSI (code 39)¹⁾, body material PP (code 5), PVDF (code 20)²⁾

MG	DN	NPS	ød		øD	FTF	H	H1	øk	øL	n
			Material								
			5	20							
50	65	2½"	4.80	4.72	7.28	11.42	3.10	1.53	5.51	0.75	4
80	80	3"	5.24	4.92	7.87	12.20	4.61	2.44	5.98	0.75	4
100	100	4"	6.22	5.91	9.02	13.78	5.51	2.95	7.48	0.75	8

Dimensions in inch

MG = diaphragm size

n = number of bolts

1) Connection type

Code 39: Flange ANSI Class 125/150 RF, length only for body configuration D acc. to EN 558 series 1, ISO 5752, basic series 1

2) Valve body material

Code 1: PVC-U, grey

Code 5: PP, reinforced

Code 20: PVDF

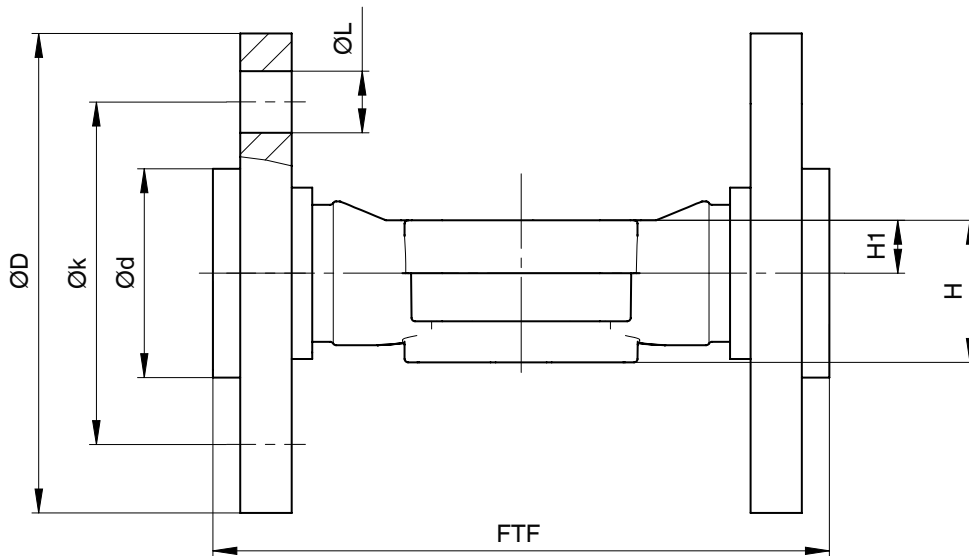

Connection type flange ANSI (code 39)¹⁾, inliner/outliner body material (code 71, 75)²⁾

MG	DN	NPS	ød	øD	FTF	H	H1	øk	øL	n
20	15	1/2"	1.77	3.74	5.12	1.42	0.39	2.36	0.63	4
	20	3/4"	2.13	4.13	5.91	1.50	0.47	2.76	0.63	4
	25	1"	2.48	4.53	6.30	1.54	0.51	3.11	0.63	4
25	32	1¼"	2.87	5.51	7.09	1.61	0.59	3.50	0.63	4
40	40	1½"	3.23	5.91	7.87	2.49	0.91	3.86	0.63	4
	50	2"	4.02	6.50	9.06	2.49	0.91	4.76	0.75	4

Dimensions in inch

MG = diaphragm size

n = number of bolts

1) **Connection type**

Code 39: Flange ANSI Class 125/150 RF, length only for body configuration D acc. to EN 558 series 1, ISO 5752, basic series 1

2) **Valve body material**

Code 71: Inliner PP-H, grey, outliner PP, reinforced

Code 75: Inliner PVDF/outliner PP, reinforced

Valve body mounting

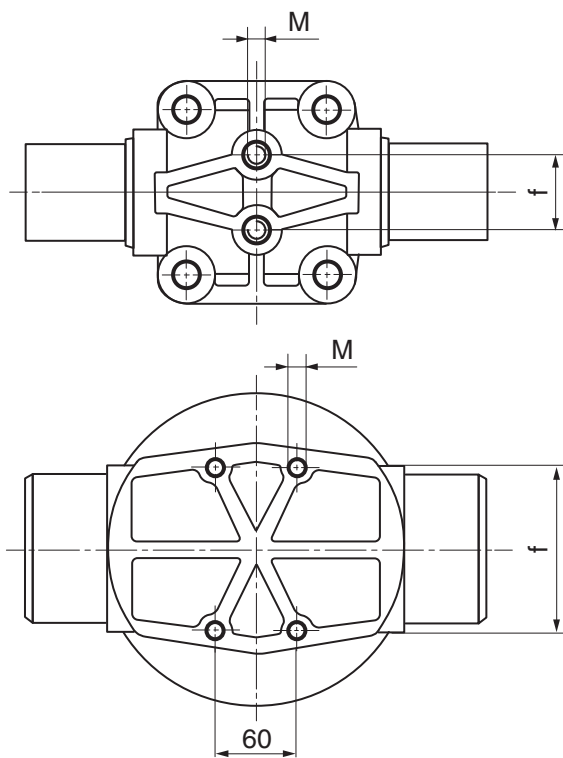

MG	DN	M Connection code 0, 4, 7, 7R, 20, 33, 39, 3M, 3T, 78	M Connection code 30	f
20	15 - 25	M6	M6 *	0.98
25	32	M6	M6 *	0.98
40	40 - 50	M8	M8 *	1.75
50	65	M8	M8 *	1.75
80	80	M12	1/2" **	3.94
100	100	M10	3/4" **	4.72

* Inch thread on request

** Metric thread on request



GEMÜ Gebr. Müller Apparatebau GmbH & Co. KG
Fritz-Müller-Straße 6-8, 74653 Ingelfingen-Criesbach, Germany
Tel. +49 (0)7940 123-0 · info@gemue.de
www.gemu-group.com