

GEMÜ 4242PTAZ

Mounting kit for pneumatic actuators

EN

Assembly instructions

Quarter turn actuator



1 General information

1.1 Description

The mounting kit is used for the mounting of electrical position indicators and combi switchboxes of series 1235, 1236, 1242, 4241 and 4242. The position of the actuator is reliably electronically detected and evaluated through play-free and non-positive mounting. The mounting kit is suitable for the following borehole pattern in accordance with VDI/VDE 3845.

1.2 NAMUR sizes, quarter turn actuator, PTAZ

The following borehole patterns are available:

80 x 30 x 20
80 x 30 x 30
130 x 30 x 30
130 x 30 x 50

1.3 Contents of PTAZ mounting kit for quarter turn actuator

The PTAZ mounting kit contains the following items:

Item
PTAZ adapter
PTAZ mounting kit
Flange plate
O-ring
Screws (4x)
Adapter (M16x1)
Operating bush
Compression spring

2 Assembly and installation

NOTICE

- Pay attention to the information on product labels, in product documentation and EC type examination certificate.
- Connect cable carefully, do not damage individual wires.
- When connecting multiwire or finewire cables, prepare the wire ends.
- Always use suitable pinch tools for pinching wire end ferrules in order to achieve consistent quality.
- Tighten all clamping points, even the ones not being used.

1. Observe the national regulations and provisions.
2. Observe the installer provisions.
3. Protect M12 plugs against electrostatic build-up.
4. Protect M12 plugs against damage.
5. Lay cables securely and protect them from damage.
6. Differential voltage for two intrinsically safe electric circuits: Maximum 30 V.
7. Connect open wire ends in a junction box with protection class IP20 and higher or outside the EX area.

2.1 Preparations for assembly to the valve (quarter turn actuator)

1. Move the actuator **A** into zero position (actuator vented).

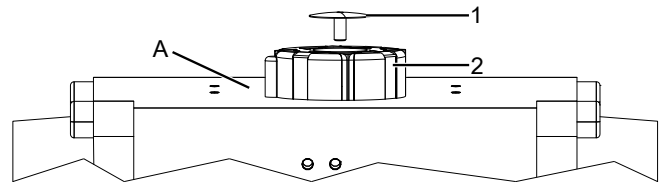

2. Remove the screw **1** from the trigger cam **2**.

2.2 Mounting kit assembly

Item	Name	Item	Name
1	Spindle	7	Flange plate
2	Spring	8	Screws
3	Operating bush	9	Pressure disc*
4	Distance piece	10	O-ring*
5	O-ring	11	O-ring*
6	Adapter		

* Included depending on version.

CAUTION

Pretensioned spring!

- ▶ Damage to the device.
- Slowly release the tension in the spring.

CAUTION

Do not scratch the spindle!

- ▶ A damaged spindle surface may cause failure of the travel sensor.

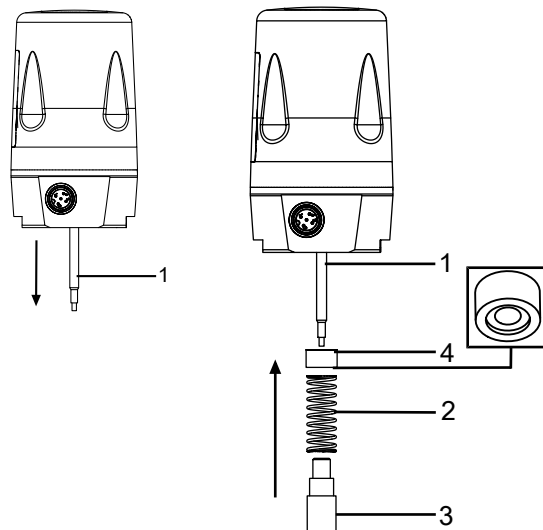

1. Pull out the spindle **1**.
2. Align the indentation of the distance piece **4** to the spring and push it over the spindle **1** using the spring **2** and fix it in place using the operating bush **3**.

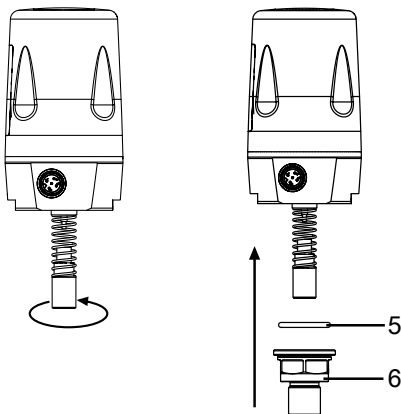

3. Tighten the operating bush **3** by turning it clockwise.
4. Affix the O-ring **5** and the adapter **6**.

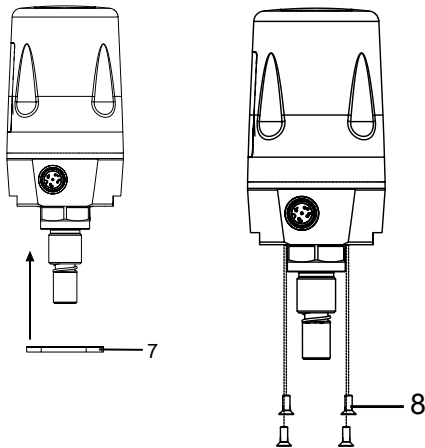

5. Attach the flange plate **7**
6. Screw the flange plate on tight using screws **8** (1 – 1,5 Nm).

- Push in the spindle until it pushes against the spring and then slowly release the pressure on the spring.

2.3 Mounting kit assembly (quarter turn actuator)

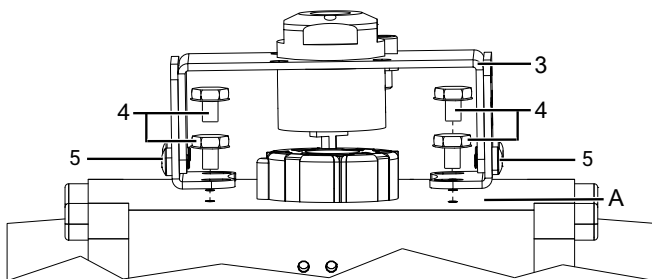

- Adjust the mounting bracket to the required borehole pattern.
 - ⇒ To do this, loosen the side screws **5** and set the retaining feet onto the thread of the actuator, and install it using screws **4**.
- Secure the bracket **3** to the retaining feet as shown. In doing so, the tap shaft must sit free of play in the shaft of the actuator.

2.4 Assembling and installing the combi switchbox (quarter turn actuator)

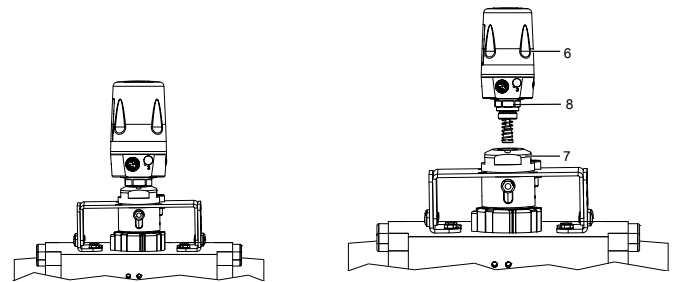

- Screw the product **6** onto the adapter **7**.
- Use the spanner flat **8** (WAF 27) of the travel sensor to tighten the product.
- Turn the housing clockwise to align the pneumatic or electrical connections.
- Connect the product electrically.
- Connect the product pneumatically.
- Initialize the product.



GEMÜ Gebr. Müller Apparatebau GmbH & Co. KG
Fritz-Müller-Straße 6-8, 74653 Ingelfingen-Criesbach, Germany
Tel. +49 (0)7940 123-0 · info@gemue.de
www.gemu-group.com

Subject to alteration

10.2023 | 88658839