

# M-Block®

## Optimal L/D ratio

Maintaining purity in processes and, in connection with this, optimizing the design of valves to allow for effective cleaning, are well known to be amongst the most challenging issues to be faced for applications such as those in the pharmaceutical industry. If a large number of single valves are welded into a pipeline, there will also generally be relatively large deadlegs. But this is not the case with M-blocks. This type of valve has been designed to minimize deadlegs.

### 1 The theoretical diameter D

From the point of view of geometry, the surface of a valve seat pocket can also take the form of a circle (see red marking in the diagram) without changing the surface area. The adjacent table provides an overview of different theoretical diameters for standard designs.

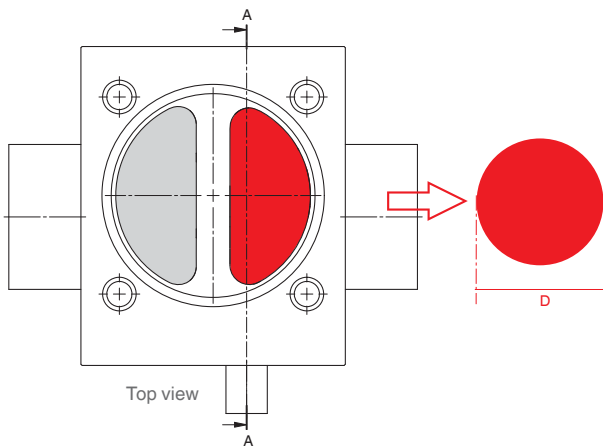

### 2 The length L and the inclination angle α

These two dimensions can be determined using the technical drawing of the valve body.

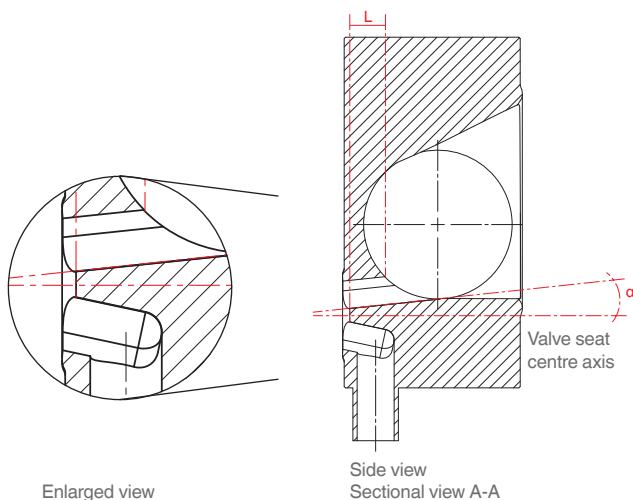

What is important here is actually the L/D ratio. This provides a guide value that indicates how easy to clean the valve will be. L/D is the formula we use – it is our benchmark for ensuring that optimal cleanability is designed into multi-port valve blocks. A simple methodology helps to make sure that this does not just work on paper, but also that it produces a meaningful comparison characteristic value in practice. The example below shows how to calculate the L/D ratio for M-blocks in just a few, simple steps.

### 3 Overview of standard designs

The table below lists the most common inclination angles in conjunction with the corresponding diaphragm sizes. These values can be used to quickly and easily calculate the theoretical diameter.

α	0°	6°	12°	≥ 45°
MG	D			
8	11.3	11.5	11.6	9.7
10	15.7	15.9	16.1	14.2
25	29.6	30.1	30.4	29.1
40	39.3	39.9	40.2	38.6
50	49.8	50.7	51.3	50.0
80	73.4	75.1	76.3	74.8
100	98.9	101.0	102.5	100.5

α = inclination angle of the valve seat pocket  
 MG = diaphragm size  
 D = diameter [mm]

### 4 The optimal L/D ratio

The relative proportions of the values ascertained for L (from the drawing) and D (from the table) are now represented as a ratio. The result allows a conclusion to be drawn with regard to whether this valve design fulfils the requirements.

$$\frac{L}{D} = \text{Cleanability guide value}$$

Example: M-block with diaphragm size 25

2 Values taken from the drawing	3 Value taken from the table	4 Calculated guide value
L = 50 mm α = 6	D = 30.1 mm	$\frac{L}{D} = \frac{50}{30.1} = 1.66$